

PLA/PLW SERIES
Programmable DC Electronic Load
Operation Manual

This manual covers models:

PLA (Air-Cooled) Series
PLW (Water-Cooled) Series



About AMETEK

AMETEK Programmable Power, Inc., a Business Unit of AMETEK, Inc., is a global leader in the design and manufacture of precision, programmable power supplies for R&D, test and measurement, process control, power bus simulation and power conditioning applications across diverse industrial segments. From bench top supplies to rack-mounted industrial power subsystems, AMETEK Programmable Power is the proud manufacturer of AMREL, Elgar, Sorensen, California Instruments, and Power Ten brand power supplies.

AMETEK, Inc. is a leading global manufacturer of electronic instruments and electromechanical devices with annualized sales of \$5 billion. The Company has over 18,000 colleagues working at more than 150 manufacturing facilities and more than 80 sales and service centers in the United States and around the world.

Trademarks

AMETEK is a registered trademark of AMETEK, Inc.

Other trademarks, registered trademarks, and product names are the property of their respective owners and are used herein for identification purposes only.

Notice of Copyright

PLW/PLA Series *Operation Manual* © May 2019 AMETEK Programmable Power, Inc. All rights reserved.

Exclusion for Documentation

UNLESS SPECIFICALLY AGREED TO IN WRITING, AMETEK PROGRAMMABLE POWER, INC. (“AMETEK”):

- (a) MAKES NO WARRANTY AS TO THE ACCURACY, SUFFICIENCY OR SUITABILITY OF ANY TECHNICAL OR OTHER INFORMATION PROVIDED IN ITS MANUALS OR OTHER DOCUMENTATION.
- (b) ASSUMES NO RESPONSIBILITY OR LIABILITY FOR LOSSES, DAMAGES, COSTS OR EXPENSES, WHETHER SPECIAL, DIRECT, INDIRECT, CONSEQUENTIAL OR INCIDENTAL, WHICH MIGHT ARISE OUT OF THE USE OF SUCH INFORMATION. THE USE OF ANY SUCH INFORMATION WILL BE ENTIRELY AT THE USER’S RISK, AND
- (c) REMINDS YOU THAT IF THIS MANUAL IS IN ANY LANGUAGE OTHER THAN ENGLISH, ALTHOUGH STEPS HAVE BEEN TAKEN TO MAINTAIN THE ACCURACY OF THE TRANSLATION, THE ACCURACY CANNOT BE GUARANTEED. APPROVED AMETEK CONTENT IS CONTAINED WITH THE ENGLISH LANGUAGE VERSION, WHICH IS POSTED AT WWW.POWERANDTEST.COM.

Date and Revision

November 2019 Revision F

Part Number

M470039-01

Contact Information

Telephone: 800 733 5427 (toll free in North America)

858 450 0085 (direct)

Fax: 858 458 0267



Email: sales.ppd@ametek.com
service.ppd@ametek.com
ppssupport.ppd@ametek.com

Web: www.powerandtest.com

This is page intentionally left blank.

Important Safety Instructions

Before applying power to the system, verify that your product is configured properly for your particular application.

| | |
|---|---|
|  Warning | Hazardous voltages may be present when covers are removed. Qualified personnel must use extreme caution when servicing this equipment. Circuit boards, test points, and output voltages also may be floating above (below) chassis ground. |
|  Warning | <i>The equipment used contains ESD sensitive ports. When installing equipment, follow ESD Safety Procedures. Electrostatic discharges might cause damage to the equipment.</i> |

Only *qualified personnel*, who deal with attendant hazards in power supplies, are allowed to perform installation and servicing.

Ensure that the AC power line ground is connected properly to the Power Rack input connector or chassis. Similarly, other power ground lines including those to application and maintenance equipment *must* be grounded properly for both personnel and equipment safety.













Always ensure that facility AC input power is de-energized prior to connecting or disconnecting any cable.

In normal operation, the operator does not have access to hazardous voltages within the chassis. However, depending on the user's application configuration, **HIGH VOLTAGES HAZARDOUS TO HUMAN SAFETY** may be normally generated on the output terminals. The customer/user must ensure that the output power lines are labeled properly as to the safety hazards and that any inadvertent contact with hazardous voltages is eliminated.

Guard against risks of electrical shock during open cover checks by not touching any portion of the electrical circuits. Even when power is off, capacitors may retain an electrical charge. Use safety glasses during open cover checks to avoid personal injury by any sudden component failure.

Neither AMETEK Programmable Power Inc., San Diego, California, USA, nor any of the subsidiary sales organizations can accept any responsibility for personnel, material or inconsequential injury, loss or damage that results from improper use of the equipment and accessories.

SAFETY SYMBOLS

| | | | |
|---|--|---|---|
|  | WARNING Risk of Electrical Shock |  | CAUTION Refer to Accompanying Documents |
|  | Off (Supply) |  | Direct Current (DC) |
|  | Standby (Supply) |  | Alternating Current (AC) |
|  | On (Supply) |  | Three-Phase Alternating Current |
|  | Protective Conductor Terminal |  | Earth (Ground) Terminal |
|  | Fuse |  | Chassis Ground |

This page intentionally left blank.

Product Family: PLA/PLW Programmable DC Electronic Loads

Warranty Period: One Year

WARRANTY TERMS

AMETEK Programmable Power, Inc. (AMETEK), provides this written warranty covering the Product stated above, and if the Buyer discovers and notifies AMETEK in writing of any defect in material or workmanship within the applicable warranty period stated above, then AMETEK may, at its option: repair or replace the Product; or issue a credit note for the defective Product; or provide the Buyer with replacement parts for the Product.

The Buyer will, at its expense, return the defective Product or parts thereof to AMETEK in accordance with the return procedure specified below. AMETEK will, at its expense, deliver the repaired or replaced Product or parts to the Buyer. Any warranty of AMETEK will not apply if the Buyer is in default under the Purchase Order Agreement or where the Product or any part thereof:

- is damaged by misuse, accident, negligence or failure to maintain the same as specified or required by AMETEK;
- is damaged by modifications, alterations or attachments thereto which are not authorized by AMETEK;
- is installed or operated contrary to the instructions of AMETEK;
- is opened, modified or disassembled in any way without AMETEK's consent; or
- is used in combination with items, articles or materials not authorized by AMETEK.

The Buyer may not assert any claim that the Products are not in conformity with any warranty until the Buyer has made all payments to AMETEK provided for in the Purchase Order Agreement.

PRODUCT RETURN PROCEDURE

1. Request a Return Material Authorization (RMA) number from the repair facility (**must be done in the country in which it was purchased**):
 - **In the USA**, contact the AMETEK Repair Department prior to the return of the product to AMETEK for repair:
Telephone: 800-733-5427, ext. 2295 or ext. 2463 (toll free North America)
858-450-0085, ext. 2295 or ext. 2463 (direct)
 - **Outside the United States**, contact the nearest Authorized Service Center (ASC). A full listing can be found either through your local distributor or our website, www.powerandtest.com, by clicking Support and going to the Service Centers tab.
2. When requesting an RMA, have the following information ready:
 - Model number
 - Serial number
 - Description of the problem

NOTE: Unauthorized returns will not be accepted and will be returned at the shipper's expense.

NOTE: A returned product found upon inspection by AMETEK, to be in specification is subject to an evaluation fee and applicable freight charges.

This page intentionally left blank.

TABLE OF CONTENTS

| | |
|--|-----------|
| ONE: FEATURES AND OPERATION OVERVIEW | 12 |
| INTRODUCTION | 12 |
| PLW MODEL NUMBER DESCRIPTION | 13 |
| PLA MODEL NUMBER DESCRIPTION | 13 |
| FEATURES AND OPTIONS | 13 |
| GENERAL INFORMATION AND OPERATING NOTES | 14 |
| OPERATING MODES | 14 |
| PROGRAMMING MODE PARAMETERS | 15 |
| INPUT CONTROL | 16 |
| TRANSIENT OPERATION | 16 |
| TRIGGER OPERATION | 17 |
| PROTECTION FEATURES | 18 |
| FRONT PANEL OPERATION QUICK GUIDE | 22 |
| LCD STATUS ENUCIATOR | 22 |
| LCD DESCRIPTION | 22 |
| FRONT PANEL KEYPAD DESCRIPTION | 23 |
| HOT KEY DESCRIPTION | 23 |
| ENCODER OPERATION | 24 |
| MODE AND MENU NAVIGATION | 25 |
| FRONT PANEL MENU TREE | 26 |
| EXTERNAL PROGRAMMING PORT | 31 |
| INPUT VOLTAGE LIMIT | 32 |
| INPUT CURRENT LIMIT | 32 |
| INPUT POWER LIMIT | 32 |
| DIMENSIONAL DRAWING & DESCRIPTIONS | 34 |
| PLW 2U MODEL | 34 |
| PLA 2U MODEL | 36 |
| PLA 3U MODEL | 38 |
| PLW 4U MODEL | 40 |
| PLA 4U and 6U MODEL | 42 |
| TWO: INSTALLATION | 44 |
| INTRODUCTION | 44 |
| BASIC SET UP PROCEDURE | 44 |
| INSPECTION, CLEANNING, AND PACKAGING | 44 |
| RETURNING ELECTRONIC LOAD TO THE MANUFACTURER | 45 |
| PACKAGING FOR SHIPPING OR STORAGE | 45 |
| LOCATION, MOUNTING, AND VENTILATION | 46 |
| FUSE REPLACEMENT | 46 |
| AC INPUT POWER CONNECTION | 47 |
| AC INPUT CONNECTOR AND VOLTAGE SELECTION | 47 |
| AC INPUT CORD | 48 |
| LOAD WIRING | 48 |
| REAR PANEL INLET & OUTLET PIPE INSTALLATION | 49 |
| RECOMMENDED WATER PIPING INSTALLATION FOR PLW SERIES | 50 |
| COOLANT WITH ANTI-FREEZE (GLYCOL) PRECAUTIONS | 51 |
| LOAD WIRING LENGTH FOR OPERATION WITH SENSE LINES | 52 |
| NOISE AND IMPEDANCE EFFECTS | 52 |
| LOAD CONNECTIONS | 52 |
| INPUT TERMINAL | 52 |
| INPUT TERMINAL CONNECTOR | 53 |

| | |
|---|-----------|
| LOCAL SENSE CONFIGURATION | 53 |
| REMOTE SENSE CONFIGURATION | 54 |
| PARALLEL CONNECTION | 54 |
| TRIGGER OPERATION | 55 |
| ZERO-VOLT LOADING CONNECTION | 56 |
| THREE: LOCAL OPERATION | 57 |
| INTRODUCTION | 57 |
| VOLTAGE AND CURRENT METERING INFORMATION | 57 |
| OPERATING STATUS INFORMATION | 57 |
| LOCAL AND GPIB OPERATION INFORMATION | 58 |
| MODE MENU OPERATION AND RANGE SETTING | 58 |
| MAIN LEVEL LOCAL OPERATION | 59 |
| ENCODER OPERATION | 60 |
| MENU FUNCTION | 60 |
| LOAD CONTROL MENU | 63 |
| STEP PARAMETERS | 63 |
| MEASURE SENSE | 63 |
| PORT 0 | 63 |
| EXTERNAL CONTROL | 64 |
| SHORT CONTROL | 65 |
| CROSS MODE | 65 |
| CROSS RANGE | 65 |
| TRIGGER SOURCE | 65 |
| PROTECTION | 65 |
| V-ON PROTECTION (UVL) | 65 |
| MAX/MIN SETTING FUNCTION | 66 |
| CALIBRATION PARAMETERS | 66 |
| OSCILLATE | 66 |
| OSC DETECTION DISABLE AND DELAY FEATURES | 66 |
| BOOT INPUT | 67 |
| LOAD PROFILE MENU | 67 |
| DISPLAY MENU | 67 |
| C OPERAND FOR BATTERY TESTING | 67 |
| SYSTEM FUNCTIONS MENU | 67 |
| GPIB FUNCTION | 67 |
| RS-232 FUNCTION | 68 |
| SYNTAX MODE | 68 |
| EOS CODE | 68 |
| BUZZER | 68 |
| PANEL LOCK | 68 |
| ETHERNET FUNCTION | 68 |
| USB FUNCTION | 70 |
| AUTHENTICATE MENU | 81 |
| SERIAL NUMBER | 81 |
| INTERFACE | 81 |
| CODE | 81 |
| TRANSIENT OPERATION | 81 |
| TRANSIENT MODE | 81 |
| ENTERING TRANSIENT MODE VALUES | 82 |
| TRANSIENT FREQUENCY, SLEW RATE AND DUTY CYCLE PROGRAMMING | 82 |
| LOCAL TRANSIENT OPERATION | 83 |
| CONTINUOUS MODE | 83 |
| TOGGLE MODE | 84 |
| PULSE MODE | 85 |
| TRIGGER MODE | 86 |
| STEP MODE | 87 |

| | |
|--|------------|
| STEP OPERATION SET-UP | 87 |
| STEP FUNCTION | 87 |
| STEP COUNT | 87 |
| STEP MODE | 87 |
| ENTERING STEPPING MODE VALUE | 88 |
| FOUR: REMOTE OPERATION | 90 |
| INTRODUCTION | 90 |
| INTRODUCTION TO GPIB & RS-232 (SCPI) COMMANDS | 90 |
| OVERVIEW SCPI LANGUAGE | 90 |
| SYNTAX OVERVIEW | 91 |
| LANGUAGE DICTIONARY | 91 |
| COMMAND STRUCTURE | 91 |
| SCPI (GPIB & RS-232) COMMAND SET | 92 |
| COMMON COMMANDS | 101 |
| COMMAND LIST | 102 |
| FIVE: CALIBRATION | 104 |
| INTRODUCTION | 104 |
| CALIBRATION SERVICE ENVIRONMENT AND PRECAUTIONS | 104 |
| CALIBRATION REQUIRED EQUIPMENT | 104 |
| CALIBRATION CONFIGURATION | 105 |
| CALIBRATION PARAMETERS | 105 |
| LOCAL CALIBRATION PROCEDURES | 106 |
| RE-INSTALLING CALIBRATION DATA | 112 |
| SIX: NEW ELOAD FEATURES | 113 |
| POWER INTERRUPTION | 113 |
| UNDER TEMPERATURE WARNING | 114 |
| INPUT CONTACTOR CONTROL | 114 |
| ULTRA-LOW RANGE OPTION | 115 |
| STEP MODE MODIFICATION | 117 |
| OSC RANGE SELECTION | 119 |
| INTERLOCK FUNCTION | 120 |
| STEP TIME UNIT | 121 |
| OVERPOWER WARNING MESSAGE | 121 |
| PV SWEEP FUNCTION | 122 |
| MASTER-SLAVE PARALLEL OPERATION | 126 |
| REMOTE INHIBIT | 130 |
| SEVEN: SPECIFICATION AND POWER CURVE | 131 |
| COMMON SPECIFICATIONS | 131 |
| PLA POWER CURVES | 133 |
| PLW POWER CURVES | 134 |
| APPENDIX A: PEL & PLA/PLW COMMAND COMPATIBILITY TABLE | 135 |
| APPENDIX B: PLW – COOLING SYSTEM GUIDELINE | 139 |
| APPENDIX C: PV SWEEP & PV OPERATION GUIDE | 155 |

TABLES AND FIGURES

| | |
|---|-----|
| TABLE 1.1a PLW GENERAL VOLTAGE AND CURRENT RANGES | 12 |
| TABLE 1.1b PLA GENERAL VOLTAGE AND CURRENT RANGES | 13 |
| FIGURE 1.1 LIQUID CRYSTAL DISPLAY | 22 |
| FIGURE 1.2 FRONT PANEL KEYPAD | 23 |
| TABLE 1.2 HOT KEY DESCRIPTION | 23 |
| TABLE 1.3 ENCODER OPERATION | 24 |
| FIGURE 1.5 INPUT VOLTAGE/CURRENT/POWER RELATION DIAGRAM | 33 |
| FIGURE 1.6 – PLW 2U FRONT PANEL | 34 |
| FIGURE 1.7 – PLW 2U REAR PANEL | 35 |
| FIGURE 1.8 – PLA 2U FRONT PANEL | 36 |
| FIGURE 1.9 – PLA 2U REAR PANEL | 37 |
| FIGURE 1.10 – PLA 3U FRONT PANEL | 38 |
| FIGURE 1.11 – PLA 3U REAR PANEL | 38 |
| FIGURE 1.12 – PLW 4U FRONT PANEL | 40 |
| FIGURE 1.13 – PLW 4U REAR PANEL | 40 |
| FIGURE 1.14 – PLA 4U FRONT PANEL | 42 |
| FIGURE 1.15 – PLA 4U REAR PANEL | 42 |
| TABLE 2.1 BASIC SETUP PROCEDURE | 44 |
| FIGURE 2.1 SHIPPING OR STORAGE PACKAGE LABEL | 46 |
| TABLE 2.2 FUSE REPLACEMENT SPECIFICATIONS | 47 |
| TABLE 2.3 AC CORD SPECIFICATIONS | 48 |
| TABLE 2.4 CURRENT CARRYING WIRING CAPACITY FOR LOAD | 48 |
| FIGURE 2.2 PIPING AND COOLANT INSTALLATION | 50 |
| TABLE 2.5 VOLTAGE DROP COMPENSATION | 52 |
| FIGURE 2.3 LOCAL SENSE CONFIGURATION | 53 |
| FIGURE 2.4 REMOTE SENSE CONFIGURATION | 54 |
| FIGURE 2.5 PARALLEL CONFIGURATION | 55 |
| FIGURE 2.6 TRIGGER CONFIGURATION | 56 |
| FIGURE 2.7 ZERO-VOLT LOADING | 56 |
| TABLE 3.1 ENCODER OPERATION | 60 |
| FIGURE 3.2 EXTERNAL PROGRAMMING SETUP | 64 |
| TABLE 3.2 TRIGGER INPUT SOURCE | 65 |
| FIGURE 5.1 CALIBRATION SETUP CONFIGURATION SETUP | 105 |

ONE: FEATURES AND OPERATION OVERVIEW

INTRODUCTION

The PLA and PLW Series Programmable DC Electronic Load (eLoad) from AMREL offers a complete solution to the electronic load system requirements. This instrument was designed to assist in the development and testing of new products, as well as is being a standard instrument for automatic test systems and evaluation of dc power supplies, batteries, and power components. Other applications include use as a power circuit breaker or crowbar, high current function or pulse generator, fuel-cell and photovoltaic cell test, and de-energizing super conducting magnets. This instrument uses advanced power MOSFETs to dissipate the input power. The electronic load consumes minimum power to control maximum input power handling capability. Complex circuits are used to control the power balance and dissipation of the MOSFET. This control circuit also supports the Constant Voltage (CV), Constant Current (CC), Constant Resistance (CR), and Constant Power (CP) modes of operation. It comes with Standard Commands for Programmable Instrument (SCPI) commands, remote monitoring of input voltage and currents is a standard features. The electronic load can be used either on your bench or in a standard 19 in. (483 mm) rack: occupies 3.5” - 8.75” (2U - 5 U) of vertical rack space. Designed for continuous use in standalone or systems applications, this electronic load is typically used to evaluate DC equipment, control circuits, or burn-in power applications.

TABLE 1.1a – PLW GENERAL VOLTAGE AND CURRENT RANGES

| | | 150A | 200A | 300A | 400A | 600A | 800A | 1000A | 1200A | 1500A |
|--------|------|------|------|------|------|------|------|-------|-------|-------|
| PLW6K | 60V | | | | | | | √ | | |
| | 120V | | | | | √ | | | | |
| | 400V | | √ | | | | | | | |
| | 600V | √ | | | | | | | | |
| PLW9K | 60V | | | | | | | | | √ |
| | 120V | | | | | | | √ | | |
| | 400V | | | √ | | | | | | |
| | 600V | | √ | | | | | | | |
| PLW12K | 60V | | | | | | | | | √ |
| | 120V | | | | | | | | √ | |
| | 400V | | | | √ | | | | | |
| | 600V | | | √ | | | | | | |
| PLW18K | 60V | | | | | | | | | √ |
| | 120V | | | | | | | | | √ |
| | 400V | | | | | √ | | | | |
| | 600V | | | | √ | | | | | |
| PLW24K | 60V | | | | | | | | | √ |
| | 120V | | | | | | | | | √ |
| | 400V | | | | | | √ | | | |
| | 600V | | | | | √ | | | | |
| PLW36K | 60V | | | | | | | | | √ |
| | 120V | | | | | | | | | √ |
| | 400V | | | | | | | | √ | |
| | 600V | | | | | | √ | | | |

Note: √ = Max Voltage & Current Rated Model; Gray Highlight – Available Model Combinations

PLW MODEL NUMBER DESCRIPTION

PLW **36K** – **400** – **300** **E**

Model Type Power Rating Voltage Rating Current Rating E-Package Suffix

TABLE 1.1b – PLA GENERAL VOLTAGE AND CURRENT RANGES

| | | 30A | 50A | 60A | 100A | 120A | 150A | 200A | 240A | 300A | 360A | 400A | 600A | 800A | 1000A | 1200A | 1500A |
|---------|------|-----|-----|-----|------|------|------|------|------|------|------|------|------|------|-------|-------|-------|
| PLA800 | 60V | | | | | | | | | √ | | | | | | | |
| | 120V | | | | | √ | | | | | | | | | | | |
| | 400V | | √ | | | | | | | | | | | | | | |
| | 800V | √ | | | | | | | | | | | | | | | |
| PLA1.5K | 60V | | | | | | | | | | | | √ | | | | |
| | 120V | | | | | | | | | √ | | | | | | | |
| | 400V | | | | √ | | | | | | | | | | | | |
| | 800V | | | √ | | | | | | | | | | | | | |
| PLA2.5K | 60V | | | | | | | | | | | | | | √ | | |
| | 120V | | | | | | | | | | | | √ | | | | |
| | 400V | | | | | | | √ | | | | | | | | | |
| | 800V | | | | | √ | | | | | | | | | | | |
| PLA3K | 60V | | | | | | | | | | | | | | √ | | |
| | 120V | | | | | | | | | | | | | √ | | | |
| | 400V | | | | | | | | | √ | | | | | | | |
| | 800V | | | | | | | √ | | | | | | | | | |
| PLA4K | 60V | | | | | | | | | | | | | | | √ | |
| | 120V | | | | | | | | | | | | | | √ | | |
| | 400V | | | | | | | | | | √ | | | | | | |
| | 800V | | | | | | | | √ | | | | | | | | |
| PLA5K | 60V | | | | | | | | | | | | | | | √ | |
| | 120V | | | | | | | | | | | | | | √ | | |
| | 400V | | | | | | | | | | | √ | | | | | |
| | 800V | | | | | | | | | √ | | | | | | | |
| PLA7.5K | 60V | | | | | | | | | | | | | | | | √ |
| | 120V | | | | | | | | | | | | | | | | √ |
| | 400V | | | | | | | | | | | | √ | | | | |
| | 800V | | | | | | | | | | | √ | | | | | |

Note: √ = Max Voltage & Current Rated Model; Gray Highlight – Available Model Combinations

PLA MODEL NUMBER DESCRIPTION

PLA **5K** – **400** – **300** **E**

Model Type Power Rating Voltage Rating Current Rating E-Package Suffix

FEATURES AND OPTIONS

- Four constant operating modes: Constant current (CC), constant voltage (CV), constant resistance (CR), and constant current (CP) mode operation.
- Local control and remote programming for pulse amplitude, pulse width, and pulse cycle.
- Trig-In/Trig-Out and measurement functions.
- GPIB, RS-232, Ethernet, and USB interface programming with SCPI command language. (Ethernet and USB are available as part of the E-Package).
- Front panel control with keypad and rotary encoder (Tune Mode) for accurate setting.

- Built in pulse generator for continuous, pulsed, and toggled transient operation.
- Seven programmable protection modes: Over Voltage Protection (OVP), Under Voltage Protection (UVP), Over Current Protection (OCP), Under Current Protection (UCP), Overpower Protection (OPP), and Under Power Protection (UPP).
- Fan speed control for reduced acoustic noise under light load conditions.
- 0-10Vdc analog programmable.
- Simple closed-case calibration.
- Highest power density: up to 18KW in 2U height
- Field-upgradeable capability for GPIB, RS232, USB and Ethernet.
- Three ranges for each operating mode; Auto or Manual
- External analog programming control for each mode and range
- Panel lock capability
- Program the Slew rise time and Slew fall time independently
- 50us transient time at CC mode; 500us transient time at CV mode
- Anti-Oscillation controls: System bandwidth controls
- Oscillation detection and protection
- Anti-Saturation controls: Under Voltage Lockout
- 16 bits programming and read back capability
- Cross mode and Cross range capability; default off
- Remote Inhibit and Dry contact Fault output
- Pulse power capability with Overpower Protection
- Field-upgradeable firmware
- Self-diagnostic capability
- Redundant Over Temperature Protection
- Four Step profiles; 256 step points for each profile
- Soft-Start Functionality
- Convenient and efficient Hot Keys for mode and Transient Mode Selection, Input and Transient On/Off Control, Slew Rate Settings, Front panel trigger, and Short.
- Independent Large Numerical Voltage and Current LED display

GENERAL INFORMATION AND OPERATING NOTES

Operating Modes:

The four modes of operation are:

Constant Current (CC):

The electronic load will sink a current in accordance with the programmed value regardless of the input voltage.

Note 1: Never use CC mode for testing a constant current source. The regulation of the two units will fight for control of the current and an unstable oscillation will result.

Note 2: During CC mode, the electronic load can operate under the fastest transient time.

Constant Voltage (CV):

The electronic load will attempt to sink enough current to control the source voltage to the programmed value. It acts as a shunt voltage regulator when operating in the CV mode.

Note 1: Never use CV mode for testing a constant voltage source. The regulators of the two devices will buck each other trying to gain control of the voltage which will lead to an unstable condition.

Note 2: In CV mode, the transient time will be adjusted to a slower setting to ensure stable operation.

Constant Resistance (CR):

The electronic load will sink a current linearly proportional to the input voltage in accordance with the programmed value.

Constant Power (CP):

The electronic load will dissipate the power in accordance with the programmed value. It will automatically adjust the current level inversely in response to a change in voltage.

Note: If the source voltage decays to zero volts the load will attempt to draw max rated current. If the OCP limit of the electronic load is greater than the current limit of the voltage source, the voltage source will be latched to the CC state. Otherwise the OCP will trip to shut down the load.

Programming Mode Parameters:

When programmed to a mode, the electronic load remains in that mode until the mode is changed or until a fault condition such as an overpower or over temperature occurrence. The current, voltage, resistance and power mode parameters can be programmed whether or not the mode is presently activated. When a mode is selected via the front panel or via the digital interfaces, the associated parameters will then take effect at the instance of turning the input on.

Cross Mode:

According to AMREL eLoad design, the electronic load has four operating modes. As part of our factory default settings, when switching from one mode to another mode in manual range (i.e. CV Low to CC High), the final switched state will have the input turned off. If an application requires the input to stay on when switching modes, the option “cross mode” must be changed from “input off” to “input remain.” By changing the option, the load will switch between modes while keeping the input on, to accommodate for the different applications of the DUT.

Note: Cross mode operation will work under both “manual” and “auto” range control mode.

Ranges:

Parameters may be programmed in any of the three overlapping ranges. The low range provides better resolution at low settings. The range can be set using the front panel or via SCPI command. For auto-range control: when you program a value, the electronic load automatically selects the range that corresponds to the value you program. If the value falls in a region where ranges overlap, the electronic load selects one with the highest resolution. In manual-range control: the programmed values will be limited by the current range setting, an OUT OF RANGE message will appear on the front panel display when an invalid value is entered. When a range is selected, the associated parameters (preset value or value from memory) will take into effect.

Cross Range Operation:

According to AMREL eLoad design specification, the electronic load has three overlapping operating ranges in each mode. As part of our factory default settings, when switching from one range to another range in manual mode (i.e. CV Low to CV High), the final switched state will have the input turned off. If an application requires the input to stay on when switching ranges, the option “cross range” must be changed from “input off” to “input remain.” By changing the option, the load will switch ranges while keeping the input on, to accommodate for the different applications of the DUT. The cross range feature allows the user to effectively switch between ranges based on the application needed by the DUT.

Note: Cross range operation will work under both “manual” and “auto” range control mode.

Immediate Level:

The immediate level can be set at front panel or via the digital interfaces. If the selected mode is active (Input on), the new setting immediately changes the input at a rate determined by the soft-start turn-on sequence of the unit. If the electronic load is not in the selected mode, the new setting is saved until that particular mode is activated.

Transient Level:

The transient level can be set at front panel or via digital interfaces. The electronic load input will switch between the main level and the transient level when transient operation is turned on. During transient operation, the load will switch from the immediate level to the transient level determined by the programmed slew time. When the load is in current control mode, avoid the main level from zero. Because control circuits are potentially off.

Triggered Level:

The level can be preset (stored in the electronic load) allowing the input to be updated when a trigger is received. Trigger level can only be changed via digital interfaces, and can be programmed to any value within the mode's range settings.

Slew Rate:

The slew rate determines the rate at which the input to the electronic load changes to a new programmed value. Slew time (positive and negative) and level change can be set at the front panel or via the digital interfaces. To better accommodate user applications, the positive and negative edge of the slew rate can be set independently. The programmed slew rate remains in effect for the triggered and transient level changes previously described.

Input Control:

Short On/Off:

The electronic load can simulate a short circuit at its input by turning the load on with full-scale current. The short circuit can be toggled on/off at the front panel or via the digital interfaces while Short On/Off is enabled. The short on/off switch-over uses the slew rate setting of the active mode and range. The actual value of the electronic short is dependent on the mode and range that are active when the short is turned on. In CV mode it is equivalent to programming zero volts. In CC mode it is equivalent to programming full-scale current for the present current range. In CR mode it is equivalent to programming the minimum resistance for the present resistance range.

Important Notes:

- 1) Turning the short on in CV mode may cause the load to draw so much current that the software current limit triggers, which may turn the input off (Protection Mode).
- 2) It is dangerous to activate short operation when testing batteries or other DUT without current limit. The eLOAD will act as an infinite current sink, and drain Maximum Current until severe damages occur to both the DUT and eLOAD. In the worst case scenario, the DUT/battery could catch on fire or explode.

Turning the short circuit on does not affect the programmed settings, and the load input will return to the previously programmed values when the short is turned off.

Input On/Off:

The electronic load's input can be toggled on/off at the front panel, or via the digital interfaces. Turning the input off (zero current) does not affect the programmed settings. The input will return to the previously programmed settings when the input is activated again.

Note: The input on/off command supersedes the mode and short on/off command.

Transient Operation:

Transient operation enables the electronic load to periodically switch between two load levels. Transient operation can be turned on and off at the front panel or via the digital interfaces. Before you turn on the transient operation, you should set the desired mode of operation as well as all of the parameters associated with transient operation under varying combinations of load levels, frequency, duty cycle, and slew rate. Transient operation may be used in CC, CR, CV or CP modes and can be continuous, pulsed, triggered, stepped or toggled. During transient operation, the load will switch from the immediate level to the transient level determined by the programmed slew time. In cases where the transition from

one level to another is less than 5% of full rating, the small signal bandwidth of the load limits the minimum transition time for all programmable slew rates. Because of this limitation, the actual transition time is longer than the expected time based on the slew rate.

Continuous Transient Operation

Generate a repetitive pulse train switches between two load levels via CONT (hot key) key or SCPI command. The two load levels in the transient operation are main level and transient level for each mode. The rate at which the level switches between is determined by the slew time setting.

Pulsed Transient Operation

Generate a load change that returns to its original state after some time period via SINGLE (hot key) key or SCPI commands.

Toggled Transient Operation

Toggled transient operation causes the electronic load input to alternate between two pre-defined load levels as in Continuous Mode except that the transient points can be controlled by explicit triggers instead of an internal transient generator.

STEP Operation:

Step mode lets you generate complex sequences of input changes with rapid, precise timing, which may be synchronized with internal or external signals.

You can program up to 256 settings (or steps) in the profile, the time interval (dwell) that each setting is maintained, the number of times that the list will be executed, and the setting's change in response to the triggers. The step data can be stored in Profile 0, 1, 2 or 3 via either the front panel or the digital interfaces. Use RCL command to recall the saved state.

Trigger Operation:

The electronic load has various triggering modes to allow synchronization with other test equipment or events.

Triggering a preset level

Transfers all pending preset levels to the actual level. For the presently active mode, the new level appears at the input. For the modes which are not presently active, the present levels will not take effect at the input until the applicable mode becomes active. However, you must first initiate the trigger function by executing the TRIG:IMMED command.

Triggering a transient pulse

A trigger signal will generate a transient pulse of programmable width when pulsed transient operation is in effect. Triggers can be sent from the front panel by pressing the TRIGGER key or via Remote Interface.

Toggling

A trigger signal will change the input between the main level and the transient level when toggled transient operation is in effect. Triggers can be sent from the front panel by pressing the TRIGGER key or via Remote Interface.

Protection Features:

The electronic load includes the following protection features:

Over Voltage (OV):

The eLOAD has an Over Voltage Protection (OV) set at 105% of the full voltage rating. If the input voltage exceeds 105% of the over voltage threshold, the input will shut off and an alarm message “OV” will display.

Over Current (OC):

The eLOAD has an Over Current Protection (OC) set at 110% of the full current rating. If the input current exceeds 110% of the over current threshold, the input will shut off and an alarm message “OC” will display.

Overpower (OP):

The eLOAD has an Overpower Protection function set at 105% of rated power. If the power based on DC input terminals voltage and current exceeds 105% of rated power, the unit will display warning message “OP” and the load will limit input current level to maintain the input power to prevent unit from over overload. Over temperature protection may trip if the input power exceeds the rated power persistently.

For eLOAD (with firmware version 2.86 or earlier), has an Overpower Protection function set at 105% (PLW Models) and 110% (PLA Models) of full Power Rating. If the accumulated energy based on operating voltage and current exceeds the overpower threshold, the input will shut down and display the alarm message “OP”.

Over Temperature (OTP):

The electronic load has an over temperature protection circuit, which will turn off the input if the internal temperature exceeds safe limits. Over-temperature is usually the worse condition to happen to an electronic load due its highly destructive effects. During high temperature operation (OTP condition), all internal MOSFETS are working near their full capacity and can fail due to excessive heat. To prevent over temperature, the electronic load has a built in redundant over temperature protection. In short, the OTP offers both a temperature sensor circuit that controls the internal cooling system and a hardware thermal switch that shuts down the input when the temperature threshold is exceeded. The heatsink temperature can be display at front panel with Meter Mode selection or Query via remote command.

Reverse Voltage (RCP):

The electronic load has the internal parallel diodes to short the input in the presence of a reversed DC voltage input. The front panel display with the alarm message “RCP” will indicate this condition has been detected.

Remote Sense Fault (RSF):

If the connection to the sense leads is not proper when operating under remote sense mode, the input will be forced off with the alarm message “RSF”; Remote Sense Fault. Two common errors that can result in “RSF” failure are while the “Measure Sense” is set to remote, the sense leads are not connected or if the leads are connected and the connection is lost. The latter can become a serious problem in CP mode. In Constant Power mode, the electronic load will maintain the set wattage by balancing the voltage and current. If the remote sense leads are disconnected, the V_{MON} of the load will sense zero voltage and sink the amount of current needed to keep the same power level until OC or other protection are triggered. The “RSF” protection will trigger if the voltage deviation between the actual measured voltage and remote sense voltage exceeds a set limit, forcing the input off until the conditions is cleared.

Note: “RSF” error signal has precedence over OC with remote sense enabled, and will trigger if connection is lost.

Unregulated state (UNR):

The “UNR” message cautions that the power stage of the electronic load is operating at its minimum resistance or equivalent to it being shorted (marginal region for the load). Another indication is that the load is being operated improperly, i.e. not enough supply current/voltage or incorrect calibration data.

Supply Current and Voltage Below Main Level

A common cause for entering the unregulated state is supplying the load with a voltage or a current below the value set for electronic load’s main level. For example, if the input is off in CV mode and the main level of the load is set at 3 volts and the power supply is programmed for 2 volts. An “UNR” alarm message will appear when turning the input on. The message is caused by the lack of voltage needed to bring the main to 3 volts, and the voltage and current readings will be unstable during this state. The same condition will occur for CC mode, if the needed current is lower than the supplied current. To fix the problem, increase the voltage or current above the needed main value. The “UNR” threshold is set as 1% deviation from the maximum value in that mode and/or range.

Re-Calibration

Verify that the supply current and voltage is sufficient for the operating condition. If the “UNR” message still occurs, check the current or voltage read back and compare it with the main value setting (CC mode: current; CV mode: voltage) to make sure the difference is below 1%. If the difference is above 1% for CC/CV mode, 30% for CR mode or 0.3% for CP mode, that particular mode will need to be recalibrated. As a factory default, all loads are calibrated to its optimal condition. Please verify the calibration inaccuracy carefully or contact AMETEK Technical Support before re-calibrating the unit.

CR and CP Mode

In CR and CP mode, if the voltage or current is below the needed value to reach a certain resistance or wattage, an “UNR” alarm message will appear. For example, in order to obtain 300 watts, the input current value multiplied by the input voltage value will need to equal 300 watts, otherwise an error will occur. For CR mode, the input voltage value divided by the input current value will need to equal the resistance value entered. To fix the problem, increase the voltage or current above the needed power or resistance. The “UNR” threshold for constant power mode is set as 0.3% deviation from the maximum value in that mode and/or range. The constant resistance mode has a higher fluctuation in its value, so it will have a higher “UNR” deviation range.

Note: When testing power supplies, a sudden current sink by the eLOAD in CP mode may cause the power supply to latch in CC mode. At that time, the eLOAD will sink no current and display “UNR”. Simply power cycle the power supply and repeat the application with a higher voltage setting to prevent the power supply from entering an uncontrollable state.

Precautions for Testing Batteries

As a precaution, when testing batteries prevent from operating in CV mode and make sure that the load does not enter the unregulated state. If a battery is connected to a short circuited load (UNR state), the load will draw infinite current and cause permanent damage to the load, battery under test and possibly start a fire.

Under Voltage Lockout Protection (UVL):

The programmable under voltage lockout feature allows the user to set a trip point between zero and full-scale voltage (V-On Voltage Threshold). The input will remain off until the input voltage is greater than the pre-programmed value or the V-On Voltage threshold. For the V-On (UVL) feature, there are two modes that can be set. In “continuous” mode, the UVL detection will remain active, and each time the voltage drops below the set threshold voltage, the UVL protection will shut off the input. Under “input on” mode, the UVL detection will only trigger once to shut down the input and will reset each time the input is cycled. The only way to clear a UVL protection message is to increase the input voltage beyond the V-On threshold. As a recommended setting, the V-On threshold should be set equivalent to at least 1 volt.

Oscillation Protection (OSC):

The eLoad offers oscillation protection to prevent the system or DUT from being damaged during unstable operating conditions. If the oscillation exceeds 1.2% of rated voltage or rated current depending on user's operational mode and over 1.5Khz frequency threshold for longer than the programmed oscillation delay, the input will shut down and an alarm message "OSC" will display. For applications with load input having dc plus ac perturbations, the OSC protection can be disabled. Please refer to the menu tree for further disabling procedures.



CAUTION

Product used with oscillation protection turned off may cause product failure. Failure occurring as a result of oscillation application or turn-off of this feature will not be covered under warranty.

Anti-Oscillation:

In addition to the "OSC" protection, the eLOAD has four selectable system bandwidth controls: Default, OSC1, OSC2 and OSC3, that will adjust the system speed to resolve potential oscillation problems. The slew time ranges will vary according to the range selected. At Default state, it has the widest bandwidth and fast transient time to achieve -3db frequency at 10Khz. At OSC1 state, it has the normal bandwidth and transient time. At OSC2 and OSC3 state, they have the slower transient time in order to have the better stability. The selection of different bandwidth ranges allows for higher speed or slower stable applications.

Self-Test Failure:

The self-test assures early detection of hardware problems and forces the input off when a failure does occur. The appropriate bit(s) in the status registers are set when any of the above protection features are active. The front panel display will indicate which condition(s) have been detected.

Resetting Latched Protection

All of the protection features remain latched (set) when they are tripped. The latched protection features can be reset via the front panel PROT (CLEAR) key or the digital interfaces. The condition that caused the protection feature to trip must be removed or it will trip again as soon as it is reset.

Bias Voltage Protection (VPP & VNP)

For the electronic load to operate properly it requires an internal +12 V_{DC} and -12V_{DC} voltage to bias different parts of the system. In the case that the +12V bias voltage malfunctions, a "VPP" error message will appear indicating a voltage positive power error. If the -12V bias voltage malfunctions, a "VNP" error will appear indicating a voltage negative power error. For either of these error messages, please contact AMETEK Technical Support. The electronic load most likely had a serious internal malfunction that caused the system to shutdown.

Note: For VPP and VNP failures, please refrain from repairing the unit, for it may inflict further damage.

In Fault Protection (INF)

If the electronic load is forced to sustain too much power, current or voltage in a short amount of time, the internal power stage may have been damaged. If the damage is serious enough, the system hardware will shut down and the display will show an "In_Fault" or "INF" error message. When this message occurs, please contact AMETEK customer service. The electronic load most likely has a power stage malfunction and will no longer operate normally.

Note: For INF failure, please refrain from repairing the unit, for it may inflict further damage.

User-Defined Over Current, Voltage, and Power Protection:

Over Voltage (OVP):

OVP is a programmable voltage trip point. Limits can be programmed to “shut down” the electronic load input if the voltage exceeds pre-programmed value (default to off). The default programmable over voltage (OVP) trip point is 105% of full voltage rating

Over Current (OCP):

Over Current Protection (OCP) is a programmable current trip point. Limits can be programmed to “shut down” the electronic load input if the current exceeds pre-programmed value for longer than the pre-set time interval (default to off). The default programmable over current (OCP) trip point is 105% of full current rating.

Overpower (OPP):

The overpower protection (OPP) is a programmable power trip point. If the input power exceeds the overpower limit, the electronic load input will shut down and display an OPP alarm message. The default programmable overpower trip point is 110% of full power rating for PLW Models and 105% of full power rating for PLA Models.

User-Defined Under Current, Voltage, and Power Protection

For flexible customer application, AMETEK’s electronic load provides a user-defined under current (UCP), under voltage (UVP) and underpower protection (UPP). If there are any applications that require a minimum voltage, current or power level for normal operation, the system will shut down when the level drops below the set value.

Custom Max/Min Value Setting

The maximum and minimum value for each mode and range is programmable.

Note: The max and min value settings must be within the limits of each individual range and mode

Low Voltage (LV) Protection

When the input voltage drops below 1.5% of the maximum voltage, a “LV” message will appear to indicate the electronic load is operating under a low voltage condition. During “LV” mode, the load will automatically switch to a slower slew time to soften high in-rush currents by limiting the speed of the current rise. The “LV” message notifies the user of a change in the slew time, so they can modify their settings to ensure proper test operation.

Self-Diagnostic Capability

Based on the system error message displayed on the front panel, certain troubleshooting analysis can be concluded and may be fixed accordingly. The error messages or alarms displayed due to “over limit” faults or erroneous operation will trigger an internal relay that shuts off the system input. For more serious failures, such as “VPP”, “VNP” or “INF,” the system has permanently shut down and will need to be shipped back to AMETEK for repair as there are other faults.

FRONT PANEL OPERATION QUICK GUIDE

LCD Status Enunciator

LIQUID CRYSTAL DISPLAY:

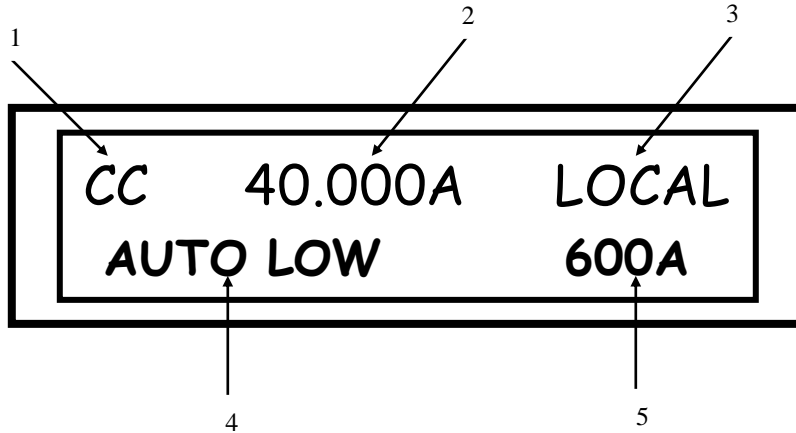

FIGURE 1.1 LIQUID CRYSTAL DISPLAYS

Important Notes:

- 1) The LCD displays real time input Voltage/Current & mode status. These messages are viewed in either local or remote mode.
- 2) The Front Panel and Remote read back provide 4 digits of display after the decimal point. Any numbers exceeding the 4th digit will be rounded to the next significant digit and displayed as the read back value.

LCD DESCRIPTION

- 1) **Mode Indicator:** Constant Voltage (CV), Constant Current (CC), Constant Resistor (CR), and Constant Power (CP).
- 2) **Main Setting Indicator:** Main Voltage, Current, Resistance and Power Setting.
- 3) **Local Mode/Remote Mode Indicator:** Local, INSC, GPIB, RS232, ETHER, and USB.
- 4) **Operating Range Indicator:** Auto, ManualLow, ManualMiddle, and ManualHigh.
- 5) **Max Range Setting Indicator:** Displays maximum value for the specified range.

Front Panel Keypad Description

| | | | |
|----------|----------|--------------|--------------|
| | | | MENU |
| 7 | 8 | 9 | LOCAL |
| | | | |
| 4 | 5 | 6 | RANGE |
| | | | |
| 1 | 2 | 3 | STEP |
| | | | |
| 0 | . | CLEAR | ENTER |

FIGURE 1.2 FRONT PANEL KEYPAD

Key “0” Numeric entry key for number 0.

Key “.” Numeric entry key for decimal dot.

Key “1” Numeric entry key for number 1.

Key “2” Numeric entry key for number 2.

Key “3” Numeric entry key for number 3.

Key “4” Numeric entry key for number 4.

Key “5” Numeric entry key for number 5.

Key “6” Numeric entry key for number 6.

Key “7” Numeric entry key for number 7.

Key “8” Numeric entry key for number 8.

Key “9” Numeric entry key for number 9.

Key “**CLEAR**” Clears partially set commands and return the unit to the metering mode. By pressing the "Clear" with no entry will display "AMREL Model number and software version.

Note: If the model name exceeds 16 digits, the displayed model name will truncate. Please refer to the model name label or use *IDN? Command to query back model name

Key “**RANGE**” Selects between auto, manual low, manual middle and manual high range.

Key “**LOCAL**” Returns from remote PC control to local operation and status indicator will change from RMT to LCL. The Local key also accesses all eLOAD menu options and parameters for configuring desired settings.

Key “**STEP**” Allows programming of time duration and value settings for step operation

Key “**ENTER**” Enters the values in the set mode and returns the unit to the metering mode.

Hot Key Description

| HOT KEYS | OFF | SOLID ON | FLASHING ON |
|----------------|---------------------|----------------------|-----------------------------|
| INPUT | INPUT OFF | INPUT ON | Press to Short |
| SHORT | SHORT OFF | SHORT ON | Press to Short |
| STEP | STEP OFF | STEP ON | Press Input to Start Step |
| PULSE | PULSE OFF | PULSE ON | Press Input to Start Pulse |
| CC | CC Mode Disabled | CC Mode Enabled | N/A |
| CR | CR Mode Disabled | CR Mode Enabled | N/A |
| CP | CP Mode Disabled | CP Mode Enabled | N/A |
| CV | CV Mode Disabled | CV Mode Enabled | N/A |
| CONT | Continuous Disabled | Continuous Enabled | N/A |
| TOGGLE | Toggle Disabled | Toggle Enabled | N/A |
| SINGLE | Single Disabled | Single Enabled | N/A |
| TRIGGER | N/A | N/A | Trigger Transient Operation |
| PEAK | Setting not Enabled | Adjust Trans. Value | N/A |
| FREQ | Setting not Enabled | Adjust Trans. Freq. | N/A |
| DUTY | Setting not Enabled | Adjust Trans. Duty | N/A |
| SLEW | Setting not Enabled | Adjust +/- Slew Rate | N/A |

TABLE 1.2 – HOT KEY DESCRIPTION

Encoder Operation

| BUTTON or SETTING | ENCODER ACTION | FUNCTION |
|--|-----------------------|--|
| Main Level Setting Screen in Main Value Edit Mode | Press & Hold | Change Input Value |
| | Tap | Change Decimal Position |
| | Rotate Left | Decrement Value |
| | Rotate Right | Increment Value |
| Main Level Setting Screen With Input On | Press & Hold | Modify/Enter Value |
| | Tap | Modify/Enter Value |
| | Rotate Left | Decrement Value (real-time) |
| | Rotate Right | Increment Value (real-time) |
| PEAK Hot Key Pressed | Press & Hold | Change Input Value |
| | Tap | Change Decimal Position |
| | Rotate Left | Decrement Value |
| | Rotate Right | Increment Value |
| DUTY Hot Key Pressed | Press & Hold | Modify/Enter Value |
| | Tap | Change Decimal Position |
| | Rotate Left | Decrement Value |
| | Rotate Right | Increment Value |
| SLEW Hot Key Pressed | Press & Hold | Make Selection/Modify/Enter Value |
| | Tap | Change Decimal Position |
| | Rotate Left | Scroll Through Selection/Increment Value |
| | Rotate Right | Scroll Through Selection/Decrement Value |
| MENU Button Pressed | Press & Hold | Select Menu Option |
| | Tap | Exit to Previous Menu |
| | Rotate Left | Scroll Through Selection |
| | Rotate Right | Scroll Through Selection |
| RANGE Button Pressed | Press & Hold | Select Mode & Range Type |
| | Tap | Select Mode & Range Type |
| | Rotate Left | Scroll Through Selection |
| | Rotate Right | Scroll Through Selection |
| STEP Button Pressed | Press & Hold | Make Selection/Modify/Enter Value |
| | Tap | Change Decimal Position |
| | Rotate Left | Scroll Through Selection/Increment Value |
| | Rotate Right | Scroll Through Selection/Decrement Value |

TABLE 1.3 – ENCODER OPERATION

Note: Press "Clear" to exit from any menu or edit mode

Mode and Menu Navigation

Mode and Menu Navigation

- 1) In meter mode, press CV, CC, CR, or CP Hot Keys to make a mode selection.
- 2) In meter mode, press RANGE from the Front Key Pad to enter into range selection mode.
- 3) Press RANGE again to make a range selection from Low, Middle, High or Auto.
- 4) The first row displays the currently selected mode and main value
- 5) The second row displays the currently selected range.
- 6) Press “ENTER” key to confirm range, and go back to meter mode.
- 7) Press “CLEAR” key to go back to metermode.
- 8) Press encoder, same as CLEAR key.
- 9) Press and hold encoder, similar to ENTER key.

Function selection mode

- 1) In meter mode, press FREQ, DUTY, or SLEW Hot Keys to enter into an edit mode.
- 2) Press SLEW to make a selection between rise time and the fall time.
- 3) Press DUTY to configure the duty cycle.
- 4) Press FREQ to configure the frequency.
- 5) Rotate ⤴⤴ the encoder to edit value by each decimal place.
- 6) Press “CLEAR” key to go back to metermode.
- 7) Press encoder, same as CLEAR key.
- 8) Press and hold encoder to enter and accept a value.

Menu mode

- 1) Press LOCAL/MENU key, or press and hold encoder to enter into menu mode.
- 2) Rotate ⤴⤴ the encoder to select menu item.
- 3) Press “ENTER” or press and hold the encoder to accept the setting.
- 4) Press “CLEAR”, or press encoder to go back to meter mode.

Note: Please refer to the front panel menu tree section for detailed menu selections.

Panel Lock

- 1) When LCD is in “Menu Mode”, select “PANEL LOCK” can set PANEL ENABLE, and PANEL PASSSSWORD.
- 2) When “PANEL ENABLE” is set to OFF, power off the PD unit and power on a gain, the local panel is disabled. All other keys are locked except “LOCAL” key. When these keys are pressed, LCD displays “LOCAL LOCKED”.
- 3) Press “LOCAL” key, users must enter PASSWORD. If the PASSWORD is correct, the LCD goes back to normalstate. Press “ENTER” key and “LOCAL” key in the same time locks all the keys again.
- 4) If users forget the password, they can use “555555” as default password.

List step edit mode

- 1) When LCD display is in meter mode, press STEP key from Front Key Pad to enter into step edit mode.
- 2) Press STEP key to make a selection between Time edit or Value edit of a step.
- 3) Press and hold the encoder to enter and accept the setting of a step.
- 4) Rotate ⤴⤴ the encoder to select step point one by one.
- 5) Press “VALUE (9)” key to edit step value.
- 6) Press “CLEAR” key to go back to metermode.

Front Panel Menu Tree

MENU

All Words in Bold are Factory Default Settings

| | | | |
|--------------|---------------|---------------------|--|
| LOAD CONTROL | STEP PARAM. | → MODE | → STEP |
| | | | → STEP AUTO |
| | | | → STEP ONCE |
| | | → COUNT | → 1 ~ INFINITY |
| | | → TIME UNIT | → MILLISECOND |
| | | | → SECOND |
| | MEASURE SENSE | → LOCAL | |
| | | → REMOTE | |
| | PORT0 | → OFF | |
| | | → ON | |
| | EXT. CONTROL | → OFF | |
| | | → ON | |
| | SHORT CONTROL | → OFF | |
| | | → ON | |
| | SHORT TIME | → 0~65535 mS | |
| | CROSS MODE | → INPUT OFF | |
| | | → INPUT REMAIN | |
| | CROSS RANGE | → INPUT OFF | |
| | | → INPUT REMAIN | |
| | RSF DETECT | → OFF | |
| | | → ON | |
| | TRIGGER | → SOURCE | → HOLD |
| | | | → BUS |
| | | | → EXTERNAL |
| | | | → ETHERNET |
| | | → DELAY | → 00000mS |
| | | → ACTION EXT. | → NONE |
| | | | → INTERLOCK- |
| | | | → INTERLOCK+ |
| | PROTECTION | → OV-PROTECTION | → OV STATE → OFF |
| | | | → ON |
| | | | → OV LIMIT → 1.05*V_{MAX} |
| | | | → OV DELAY → 01000mS |
| | | → UV-PROTECTION | → UV STATE → OFF |
| | | | → ON |
| | | | → UV LIMIT → 000.000V |

| | | | |
|-----------------|-----------------|--------------------------|---------------------------------|
| | | → UV DELAY | → 01000mS |
| | → OC-PROTECTION | → OC STATE | → OFF → ON |
| | | → OC LIMIT | → 1.05* I_{MAX} |
| | | → OC DELAY | → 01000mS |
| | → UC-PROTECTION | → UC STATE | → OFF → ON |
| | | → UC LIMIT | → 000.000A |
| | | → UC DELAY | → 01000mS |
| | → OP-PROTECTION | → OP STATE | → OFF → ON |
| | | → OP LIMIT | → 1.05* P_{MAX} |
| | | → OP DELAY | → 01000mS |
| | → UP-PROTECTION | → UP STATE | → OFF → ON |
| | | → UP LIMIT | → 000.000W |
| | | → UP DELAY | → 01000mS |
| | → V-ON CONTROL | → V-ON STATE | → INPUT ON → CONTINUE |
| | | → V-ON THRESHOLD | → 01.000V |
| MAX/MIN LIMIT | → MAX VOLTAGE | → V_{MAX} | |
| | → MIN VOLTAGE | → 000.000V | |
| | → MAX CURRENT | → I_{MAX} | |
| | → MIN CURRENT | → 000.000A | |
| | → MAX RESIST. | → R_{MAX} | |
| | → MIN RESIST. | → R_{MIN} | |
| | → MAX POWER | → P_{MAX} | |
| | → MIN POWER | → 000.000W | |
| CAL. PARAM. | → MEASURE LOW | → 06400 | COUNT |
| | → MEASURE HIGH | → 32000 | COUNT |
| | → TRAN. OFFSET | → 06400 | COUNT |
| OSCILLATE | → OSC. CONTROL | → DEFAULT | |
| | | → OSC1 | |
| | | → OSC2 | |
| | | → OSC3 | |
| | | → DEFA. + DISABLE | |
| | | → OSC1+DISABLE | |
| | | → OSC2+DISABLE | |
| | | → OSC3+DISABLE | |
| | → OSC. DELAY | → 01000ms | |
| BOOT INPUT | → OFF | | |
| | → ON | | |
| INPUT CONTACTOR | → CONTROL | → DISABLE | |
| | | → PORT0+ @ ON | |
| | | → PORT0+ @ ON | |
| | | → RELAY @ INPUT | |
| | | → RELAY @ KEY | |

| | | | |
|---------------|--|---------------|------------------------|
| | | → DELAY | → 0-500ms |
| VALVE CONTROL | | → VALVE ON @ | → 32.0 DEGREE C |
| | | → VALVE OFF @ | → 28.0 DEGREE C |
| | | → INDICATOR | → OFF |
| | | | → ON |

Note: In firmware version 2.90 or earlier, Valve Control is a reserved function for factory use only.

| | | | |
|---------|--------|------------------|------------|
| PROFILE | RECALL | → 0 | → - DONE - |
| | | → 1 | → - DONE - |
| | | → 2 | → - DONE - |
| | | → 3 | → - DONE - |
| | SAVE | → 0 | → - DONE - |
| | | → 1 | → - DONE - |
| | | → 2 | → - DONE - |
| | | → 3 | → - DONE - |
| | RESET | → ENTER TO RESET | → - DONE - |

| | | |
|---------|----------------|---------------------|
| DISPLAY | METER MODE | → V+I |
| | | → V+P |
| | | → V+C |
| | | → V+R |
| | | → I+P |
| | | → I+C |
| | | → I+R |
| | | → R+P |
| | | → R+C |
| | | → P+C |
| | | → V+T |
| | | → I+T |
| | | → R+T |
| | | → P+T |
| | | → C+T |
| | METER POLARITY | → NORMAL (+) |
| | | → REVERSE (-) |
| | 'C' VALUE | → 1.0000A |
| | MEAS. BUFFER | → 8 |
| | | → 16 |
| | | → 32 |
| | | → 64 |
| | | → 128 |
| | | → 256 |

| | | |
|--------|--------------|------------------|
| SYSTEM | GPIB ADDRESS | → 5 |
| | RS-232 SPEED | → 2400 |
| | | → 4800 |
| | | → 9600 |
| | | → 19200 |
| | | → 38400 |
| | | → 57600 |
| | | → 115200 |
| | SYNTAX MODE | → PLA/PLW |

| | | | |
|---------------|-----------------|-------------------|-------------------|
| | | → PEL | |
| | | → PEL RANGE | |
| | EOS CODE | → CR+LF | |
| | | → NULL | |
| | | → CR | |
| | | → LF | |
| | BUZZER | → ON | |
| | | → OFF | |
| | INHIBIT CONTROL | → LATCHED | |
| | | → LIVE | |
| | PANEL LOCK | → PANEL ENABLE | → ON |
| | | | → OFF |
| | | → PANEL PASSWD | (Default: 555555) |
| | ETHERNET | → ADDRESS | 0.0.0.0 |
| | | → NETMASK | 0.0.0.0 |
| | | → GATEWAY | 0.0.0.0 |
| SWEEP CONTROL | ENABLE | →ON | |
| | | → OFF | |
| | MODE | → PV | |
| | | →CV | |
| | | →CC | |
| | | →CR | |
| | | →CP | |
| | START VALUE | → 0.00000 | |
| | STOP VALUE | → 0.00000 | |
| | STEP VALUE | → 0.00000 | |
| | STEP TIME | → 00100 mS | |
| | INPUT OPTION | → OFF | |
| | | →ON @ Vmp | |
| AUTHENTICATE | SERIAL NO. | → 000B87XXXXXX | |
| | INTERFACE | → GPIB ETHER USB | |
| | CODE | → _____ | |

HOT KEYS

| | | |
|---------------|--------|--------------------------------|
| <u>ON/OFF</u> | →INPUT | OFF “FLASHING” ON |
| | →SHORT | OFF “FLASHING” ON |
| | →STEP | OFF “FLASHING” ON |
| | →PULSE | OFF “FLASHING” ON |

Note: “Flashing” stands for a blinking light displayed on the key being pressed

| | | | |
|--------------|----------------|---------------------------|---|
| <u>RANGE</u> | →AUTO | | |
| | →MANU LOW | | |
| | →MANU MID | | |
| | →MANU HI | | |
| <u>STEP</u> | →STEP | →TIME | → 00000 ms |
| | | →VALUE | → 000.000V/A/Ω/W |
| | | (PRESS ENCODER TO ENTER.) | |
| | →ENCODER RIGHT | | → +1 for Point of step (increment step# by 1) |
| | →ENCODER LEFT | | → -1 for point of step (decrement step# by 1) |

| | | |
|------------------|------|-------------|
| <u>MODE/MAIN</u> | → CC | →OFF →ON |
| | →CR | →OFF →ON |
| | →CP | →OFF →ON |
| | →CV | →OFF →ON |

By default the range is set to AUTO RANGE and mode is set to CCL

| | | |
|--------------|----------|--------------------|
| <u>PULSE</u> | →PEAK | →001.000A |
| | →FREQ | →20Hz |
| | →DUTY | →50% |
| | →SLEW | →RISE →5ms |
| | | →FALL →5ms |
| | →CONT | →ON →OFF |
| | →TOGGLE | →ON →OFF |
| | →SINGLE | →PULSE →ON →OFF |
| | | →PINT →ON →OFF |
| | →TRIGGER | →BLINK →OFF |

EXTERNAL PROGRAMMING PORT

The external programming port provides remote sense inputs, input voltage monitoring, input current monitoring, external trigger input, external trigger output, and analog programming signal.

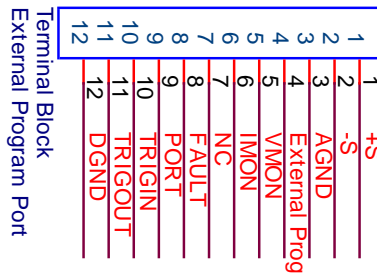

| | | |
|----|----------|---|
| 1 | +S | Positive remote sense. |
| 2 | -S | Negative remote sense. |
| 3 | EXT_GND | Analog Ground. Provides common (reference) connection for EXT_PRG (PIN 4), VMON (PIN 5), and IMON (PIN 6). When an external programming function is not used, connect this point to Analog pin 4 to prevent EMI Noise. |
| 4 | EXT_PRG | External analog programming input signal. The electronic load can be programmed externally by 0-10Volts DC or DC + AC voltage (AC voltage must be biased to above 0V). When external analog programming function is not used, connect this point to AGND pin 3 to prevent EMI Noise. |
| 5 | VMON | Input voltage monitoring signal. Generates a 0-10Volt output signal that is linearly proportional to the electronic load's 0 to full-scale voltage . |
| 6 | IMON | Input current monitoring signal. Generates a 0-10Volt output signal that is linearly proportional to the electronic load's 0 to full-scale current . |
| 7 | NC | No Connection |
| 8 | FAULT | Fault signal output. A TTL compatible signal that becomes active (high) when any of the protections are triggered. |
| 9 | PORT | Digital port output. Port can be activated via front panel operation or by SCPI command PORT 0 1 off on. PORT becomes active (high) when the PORT is on. |
| 10 | TRIG_IN | Negative Edge Triggered External trigger signal input. A TTL compatible signal is used to activate the electronic load. TRIG_IN is used to change to a preset mode or switch between settings in transient mode, such as trigger the step mode, trigger mode, continuous mode, toggle mode, step auto mode, step once mode, or pulse mode. <i>NOTE: IN ORDER TO ENABLE THE TRIG_IN PORT FOR USE, THE TRIGGER SOURCE MUST BE SET TO EXTERNAL.</i> |
| 11 | TRIG_OUT | External trigger signal output. A TTL compatible signal that is activated via the Trig-in or GPIB command *TRG. This output follows the state of the TRIG_IN input. External trigger output is used for triggering oscilloscopes, power supplies, or other electronic loads that have external trigger input. |
| 12 | EGND | Earth Ground. Provides the common (reference) connection for TRIG_IN (PIN 10), TRIG_OUT (PIN 11), Fault (PIN 8), and PORT (PIN 9). |

INPUT VOLTAGE LIMIT

The programmable electronic load can handle voltages within nominal values and surge voltages less than 5% above nominal value. The Over-voltage protection will be tripped when the input voltage exceeds 5% of nominal value. For CV mode application, the input power source should have current limit capability to prevent exceeding the electronic load's input current range.

Two over voltage protection features have been provided. 1) Over voltage protection to limit maximum current to 5% above nominal value. 2) Software selectable, the user can set and read back the input protection voltage level.



WARNING

High voltage and high current operation may result in a fault condition, shutting down the Load input. Ensure that the maximum voltage and current applied to the electronic load does not exceed the power rating.

INPUT CURRENT LIMIT

The nominal current values are indicated in the specification datasheet. During Load bank operation in CV (Constant Voltage) mode, limiting the input current at high voltages become a critical factor. The internal structure of the Load Bank and the Over-Current protection will limit the maximum current to less than 5% above nominal rated current. However, the combined input current and voltage can easily exceed the maximum rated power. If the power overload condition persists over a time period, the accumulated over-power energy will trigger the hardware OP protection, and control the input current to not exceed 120% of max rated power. For CC mode operation, the input power source should be a CV source or operate in CV mode, to avoid potential unstable conditions caused by two Constant Current Control loops. As for overpower conditions in CC mode, please limit the input voltage to prevent the OP fault condition shutting down the Load input.

Two over current protection features have been provided. 1) Over current protection to limit maximum current to 5% above nominal value. 2) Software selectable, the user can set and read back the input protection current level.



WARNING

High voltage and high current operation may result in a fault condition, shutting down the Load input. Ensure that the maximum voltage and current applied to the electronic load does not exceed the power rating.

INPUT POWER LIMIT

The programmable electronic load is designed to handle power up to 110% of Max Power Rating, with input voltage and current below the max rated specifications. As a recommendation, the input power source should not exceed the max rated power, to avoid fault conditions shutting the Load input off. As indicated in the specification sheet, Constant Power mode requires a current limit for each range (CPL, CPM, and CPH), which cannot exceed the corresponding current range max value (CCL, CCM, and CCH).



WARNING

Anticipate the Maximum output of the power source carefully and consider the worst-case scenario. The maximum power range of the load should be higher than the output power of the source. High voltage and high current operation may result in a fault condition, shutting down the Load input.

For CP mode application, the programmable electronic load can be set to maximum power dissipation with the following limitations. Input must be within maximum voltage and current ratings. For example, PLA1.2K-120-200, the max rated values are 120V/200A/1200W. Therefore, the maximum power will be limited to a combination of “voltage x current values” equating to 1,200W. Thus, CP mode is limited by the hardware's maximum current, voltage and power ratings.

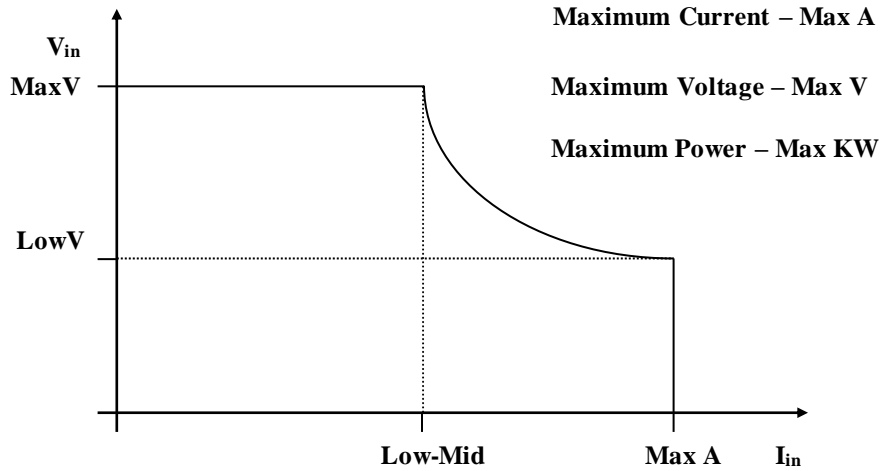

FIGURE 1.5 INPUT VOLTAGE/CURRENT/POWER RELATION DIAGRAM

The theory of the CP operation comes from the divider circuit built in the load. Because of the nonlinear characteristic of the divider, the input voltage, input current, and power setting will limit the CP mode of operation. The CP mode will not allow the load to operate beyond the full range of the Constant Power setting.

DIMENSIONAL DRAWINGS & DESCRIPTIONS

PLW 2U MODEL

Note: Please refer to the Specifications for detailed unit dimensions

Front Panel

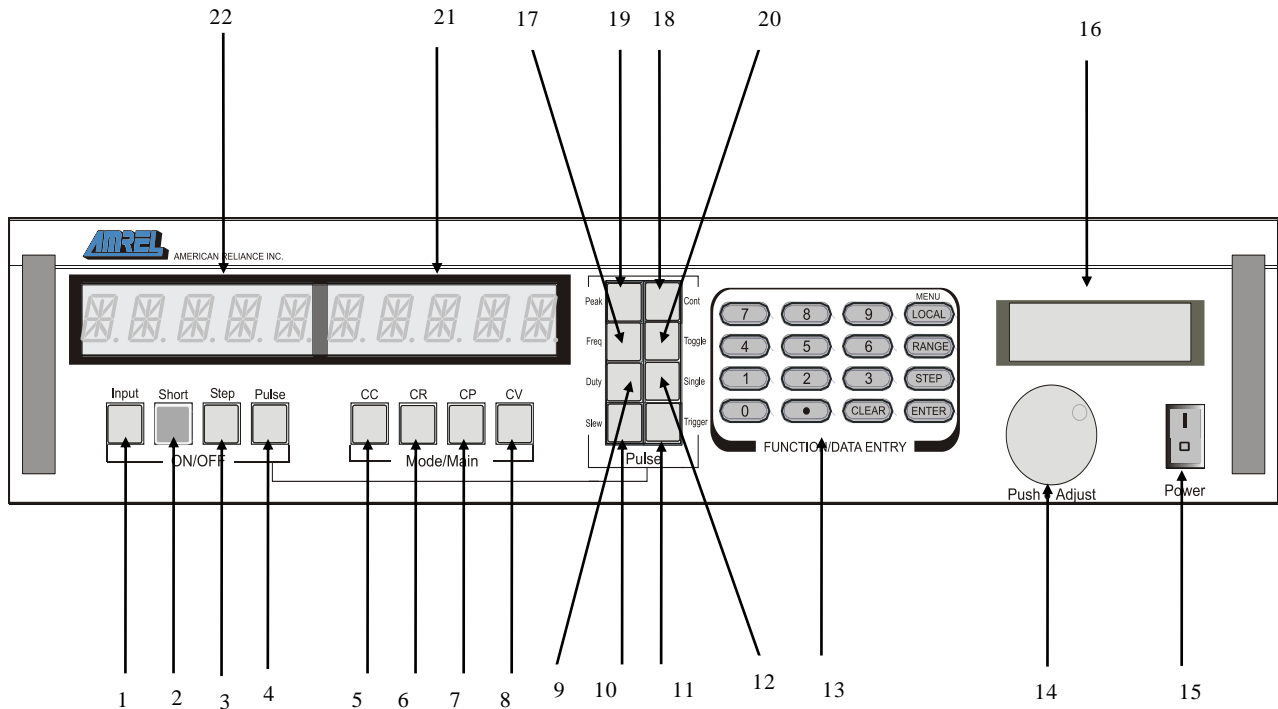

FIGURE 1.6 – 2U FRONT PANEL

- | | |
|---|---|
| 1. Input ON/OFF Button | 13. Front Panel Keypad |
| 2. Short ON/OFF Button | 14. Encoder |
| 3. Step ON/OFF Button | 15. Power ON/OFF Button |
| 4. Pulse (Transient) ON/OFF Button | 16. LCD Display |
| 5. Constant Current Mode Selection | 17. Toggle Transient Operation Selection |
| 6. Constant Resistance Mode Selection | 18. Continuous Transient Operation Selection |
| 7. Constant Power Mode Selection | 19. Transient Level Setting |
| 8. Constant Voltage Mode Selection | 20. Transient Frequency Setting |
| 9. Transient Duty Cycle Setting | 21. Current & Warning Signal LED 5 digits Display |
| 10. Slew Rate Rising/Falling Time Setting | 22. Voltage LED 5 digits Display |
| 11. Manual Trigger Button | |
| 12. Single Pulse / Power Interruption Transient Operation Selection | |

Rear Panel

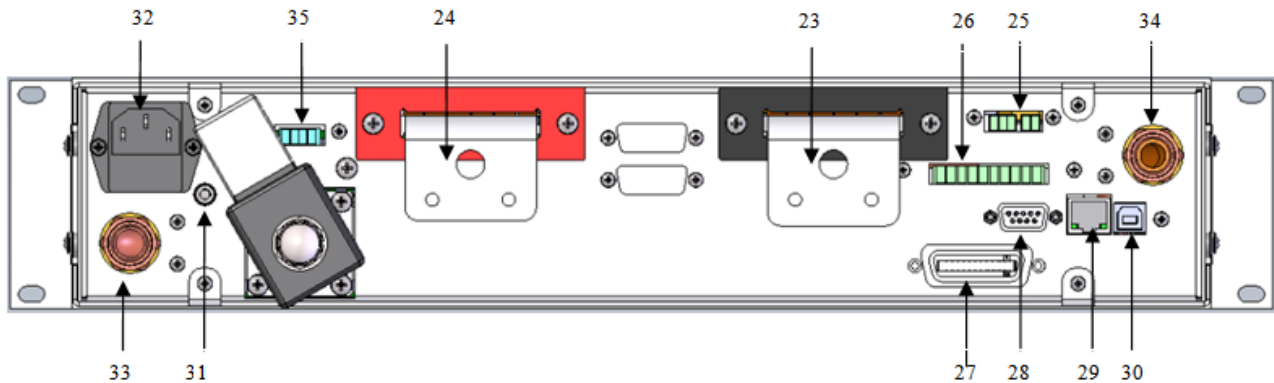

FIGURE 1.7 – PLW 2U REAR PANEL

23. (-) Negative input terminal. (Thread : one M12 ,two M6)

24. (+) Positive input terminal. (one M12 two M6 screw threads)

25. Relay connector.

- a. RY_NC Dry Contacts alarm: a fault alarm is declared if there is a loss of AC power or protections are triggered. The fault alarm outputs provide a normally closed relay configuration that provides user's flexibility and isolation required to an external controller or an external alarm panel. The delay is 3 second
- b. RY_CO Relay Common. Provides the common (reference) connection only for RY_NC or RY_NO
- c. RY_NO Dry Contacts alarm: a fault alarm is declared if there is a loss of AC power or protections are triggered. The fault alarm outputs provide a normally open relay configuration that provides user's flexibility and isolation required to an external controller or an external alarm panel. The delay is 3 second.
- d. RI_1 Remote Inhibited (RI) is used as an emergency switch to disable the system. RI can be connecting to a switch or an open collector device that shorts the RI pin to common (EGND) whenever it is necessary to disable input of the unit. Once RI is activated, it will turn off the dc output. In order to re-activate the unit, the connection between common and RI pin needs to be open again, and it will have 3 seconds delay.

26. External programming port.

27. Connector, GPIB/IEEE-488.2.

28. Connector, DB9 for RS232.

29. Connector, RJ45 for Ethernet interface (LAN).

30. Connector, USB.

31. Chassis / Line ground lug screw.

32. AC power inlet with external fuse holder.

33. Water inlet (Pipe size: 3/8" NPT)

34. Water outlet (Pipe size: 3/8" NPT)

35. Water valve power connector

PLA 2U MODEL

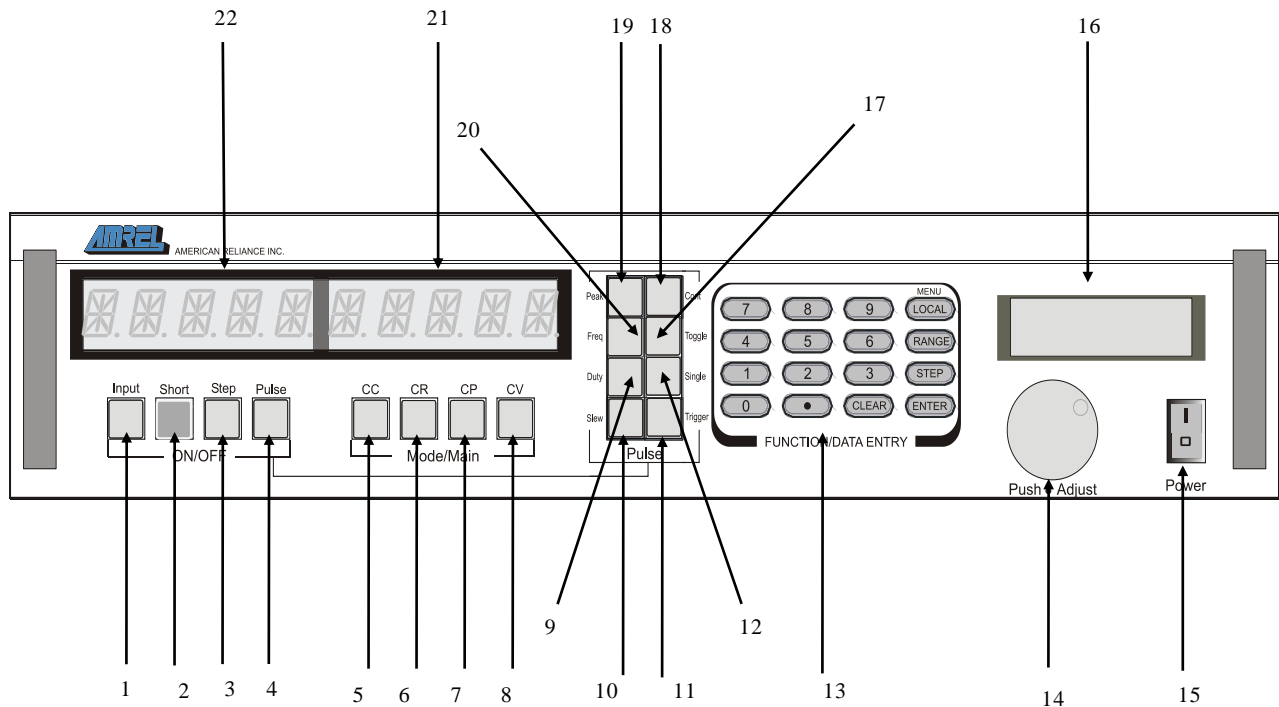

FIGURE 1.8 – PLA 2U FRONT PANEL

Note: Please refer to the Specifications for detailed unit dimensions

Front Panel Descriptions

- | | |
|---|---|
| 1. Input ON/OFF Button | 12. Single Pulse / Power Interruption Transient Operation Selection |
| 2. Short ON/OFF Button | 13. Front Panel Keypad |
| 3. Step ON/OFF Button | 14. Encoder |
| 4. Pulse (Transient) ON/OFF Button | 15. Power ON/OFF Button |
| 5. Constant Current Mode Selection | 16. LCD Display |
| 6. Constant Resistance Mode Selection | 17. Toggle Transient Operation Selection |
| 7. Constant Power Mode Selection | 18. Continuous Transient Operation Selection |
| 8. Constant Voltage Mode Selection | 19. Transient Level Setting |
| 9. Slew Rate Duty Cycle Setting | 20. Transient Frequency Setting |
| 10. Slew Rate Rising/Falling Time Setting | 21. Current & Warning Signal 5 digits Display |
| 11. Manual Trigger Button | 22. Voltage LED 5 digits Display |

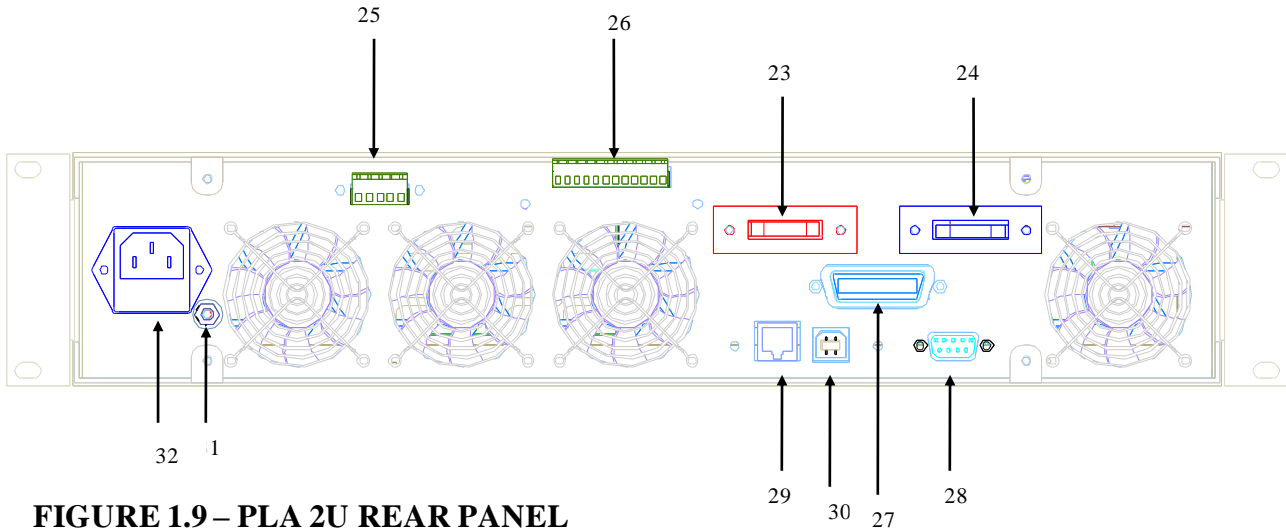

FIGURE 1.9 – PLA 2U REAR PANEL

Rear Panel Descriptions

- 23. (+) Positive input terminal. (one M10 screw thread)
- 24. (–) Negative input terminal. (one M10 screw thread)
- 25. Relay connector.
 - a. RY_NC Dry Contacts alarm: a fault alarm is declared if there is a loss of AC power or protections are triggered. The fault alarm outputs provide a normally closed relay configuration that provides user’s flexibility and isolation required to an external controller or an external alarm panel. The delay is 3 second
 - b. RY_CO Relay Common. Provides the common (reference) connection only for RY_NC or RY_NO
 - c. RY_NO Dry Contacts alarm: a fault alarm is declared if there is a loss of AC power or protections are triggered. The fault alarm outputs provide a normally open relay configuration that provides user’s flexibility and isolation required to an external controller or an external alarm panel. The delay is 3 second.
 - d. RI_1 Remote Inhibited (RI) is used as an emergency switch to disable the system. RI can be connecting to a switch or an open collector device that shorts the RI pin to common (EGND) whenever it is necessary to disable input of the unit. Once RI is activated, it will turn off the dc output. In order to re-activate the unit, the connection between common and RI pin needs to be open again, and it will have 3 seconds delay.
- 26. External programming port.
- 27. Connector, GPIB/IEEE-488.2.
- 28. Connector, DB9 for RS232.
- 29. Connector, RJ45 for Ethernet interface (LAN).
- 30. Connector, USB.
- 31. Chassis / Line ground lug screw.
- 32. AC power inlet with external fuse holder.

PLA 3U MODEL

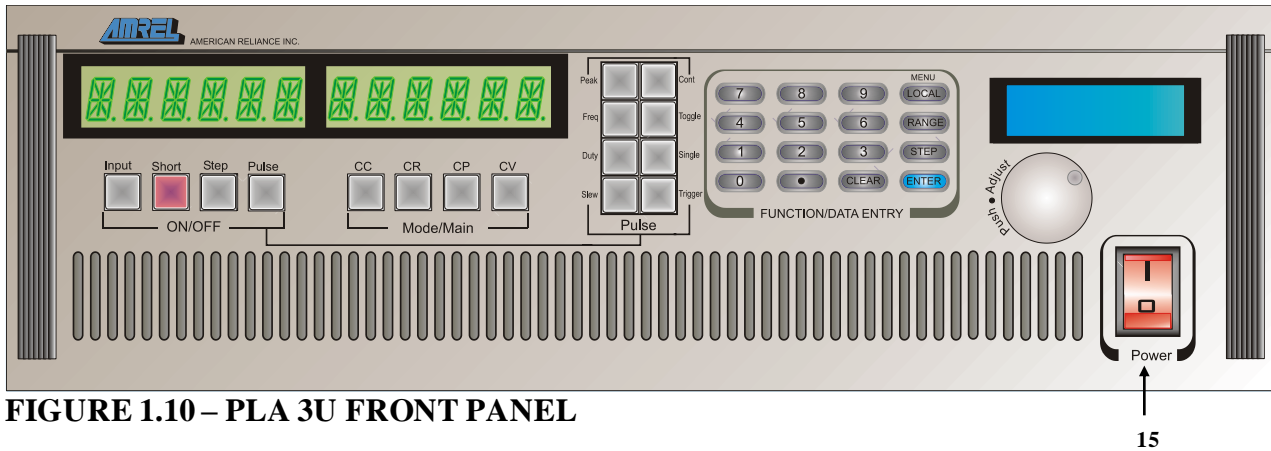

FIGURE 1.10 – PLA 3U FRONT PANEL

NOTE: All front panel descriptions are the same for 2U, 3U, 4U, and 6U. see Figure 1.8.

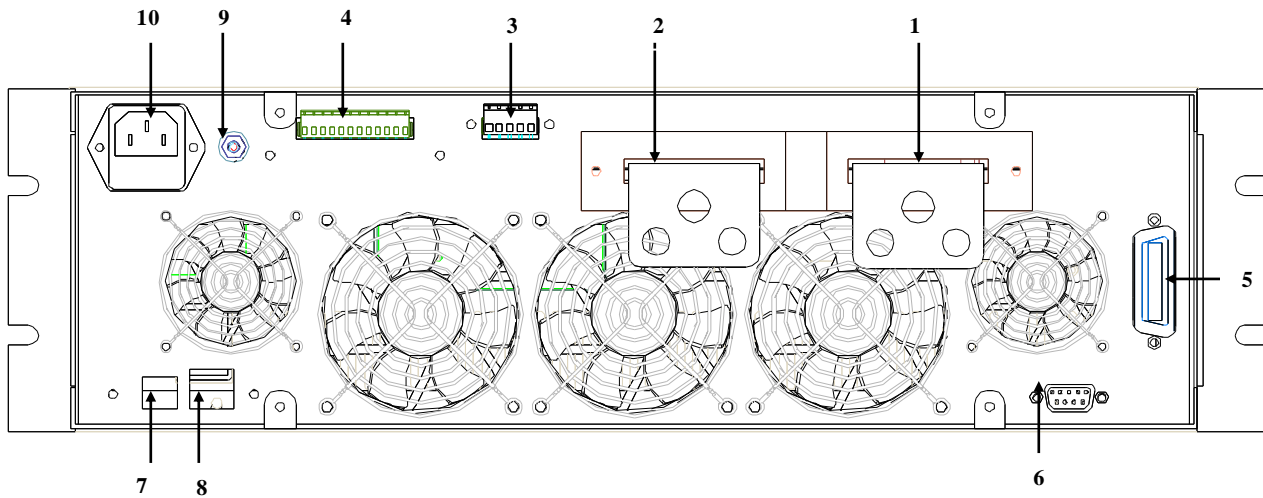

FIGURE 1.11 – PLA 3U REAR PANEL

1. (–) Negative input terminal. (one M10 ,two M6 screw threads)
2. (+) Positive input terminal. (one M10 ,two M6 screw threads)
3. Relay connector.
 - a. RY_NC Dry Contacts alarm: a fault alarm is declared if there is a loss of AC power or protections are triggered. The fault alarm outputs provide a normally closed relay configuration that provides user’s flexibility and isolation required to an external controller or an external alarm panel. The delay is 3 second
 - b. RY_CO Relay Common. Provides the common (reference) connection only for RY_NC or RY_NO
 - c. RY_NO Dry Contacts alarm: a fault alarm is declared if there is a loss of AC power or protections are triggered. The fault alarm outputs provide a normally open relay configuration that provides user’s flexibility and isolation required to an external controller or an external alarm panel. The delay is 3 second
 - d. RI_1 Remote Inhibited (RI) is used as an emergency switch to disable the system. RI can be connecting to a switch or an open collector device that shorts the RI pin to common (EGND) whenever it is necessary to disable

input of the unit. Once RI is activated, it will turn off the dc output. In order to re-activate the unit, the connection between common and RI pin needs to be open again, and it will have 3 seconds delay.

4. External programming port.
5. Connector, GPIB/IEEE-488.2.
6. Connector, DB9 for RS232.
7. Connector, RJ45 for Ethernet interface (LAN).
8. Connector, USB.
9. Chassis / Line ground lug screw.
10. AC power inlet with external fuse holder.

PLW 4U MODEL

Note: Please refer to the Specifications for detailed unit dimensions

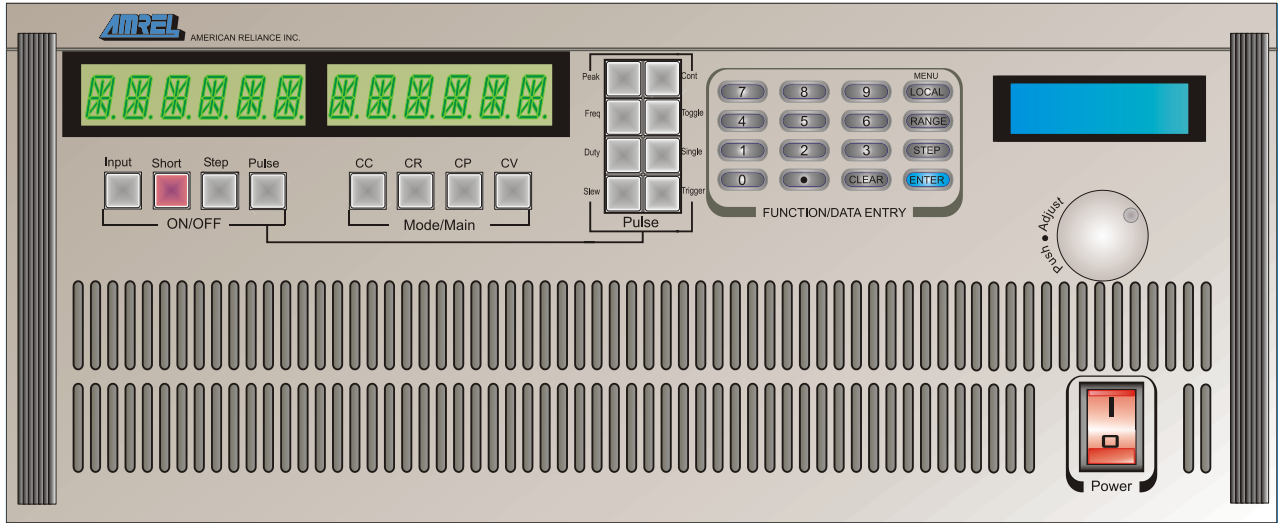

FIGURE 1.12 – PLW 4U FRONT PANEL

NOTE: All front panel descriptions are the same for 2U and 4U.

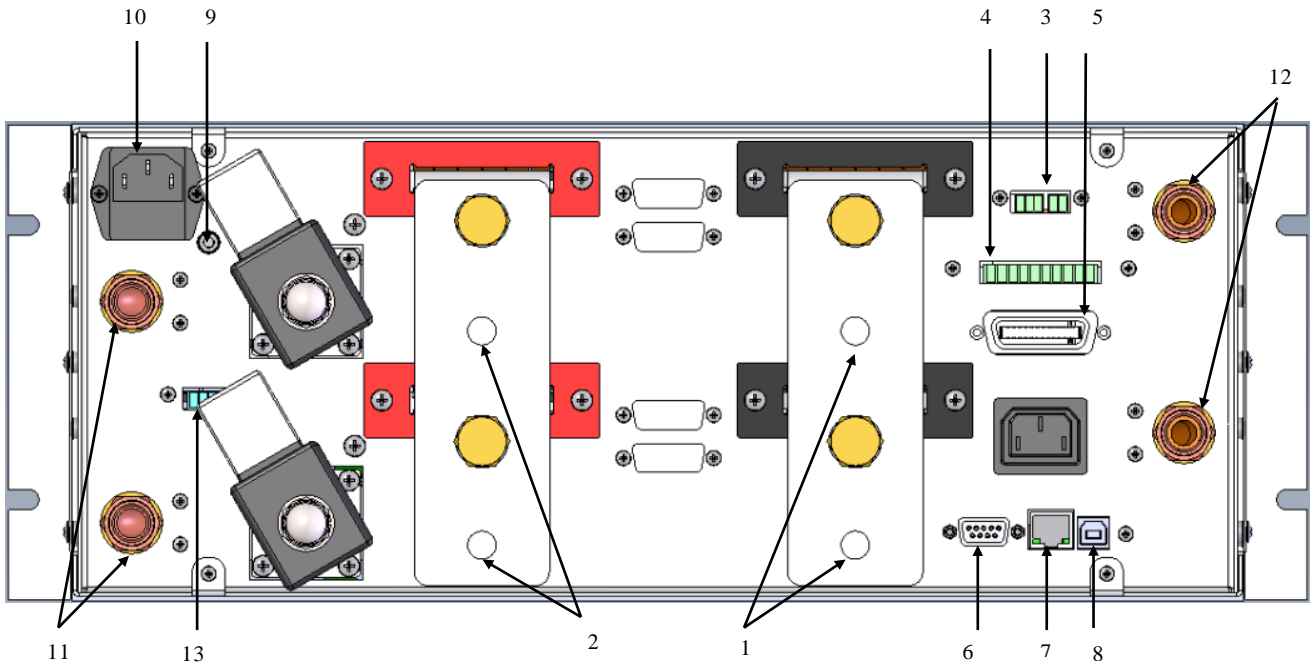

FIGURE 1.12 – PLW 4U REAR PANEL

Note: Please refer to the Specifications for detailed unit dimensions

1. (-) Negative input terminal. (two M12 screw threads)
2. (+) Positive input terminal. (two M12 screw threads)
3. Relay connector.
 - a. **RY_NC** Dry Contacts alarm: a fault alarm is declared if there is a loss of AC power or protections are triggered. The fault alarm outputs provide a normally closed relay configuration that provides user's flexibility and isolation required to an external controller or an external alarm panel. The delay is 3 second
 - b. **RY_CO** Relay Common. Provides the common (reference) connection only for RY_NC or RY_NO
 - c. **RY_NO** Dry Contacts alarm: a fault alarm is declared if there is a loss of AC power or protections are triggered. The fault alarm outputs provide a normally open relay configuration that provides user's flexibility and isolation required to an external controller or an external alarm panel. The delay is 3 second.
 - d. **RI_1** Remote Inhibited (RI) is used as an emergency switch to disable the system. RI can be connecting to a switch or an open collector device that shorts the RI pin to common (EGND) whenever it is necessary to disable input of the unit. Once RI is activated, it will turn off the dc output. In order to re-activate the unit, the connection between common and RI pin needs to be open again, and it will have 3 seconds delay.
4. External programming port.
5. Connector, GPIB/IEEE-488.2.
6. Connector, DB9 for RS232.
7. Connector, RJ45 for Ethernet interface (LAN).
8. Connector, USB.
9. Chassis / Line ground lug screw.
10. AC power inlet with external fuse holder.
11. Water inlet (Pipe size: 3/8" NPT)*
12. Water outlet (Pipe size: 3/8" NPT)*
13. Water valve power connector

*To accommodate different cooling system requirements, every AMREL standalone 4U Water-cooled eLoad is supplied with a set of detached external piping kit. MANIFOLD-4U converts two 3/8" NPT into one 1/2" NPT pipe size for both water inlet and outlet. Appendix B Section 6 provides detail installation of MANIFOLD-4U to a 4U water cooled eLoad.

PLA 4U AND 6U MODEL

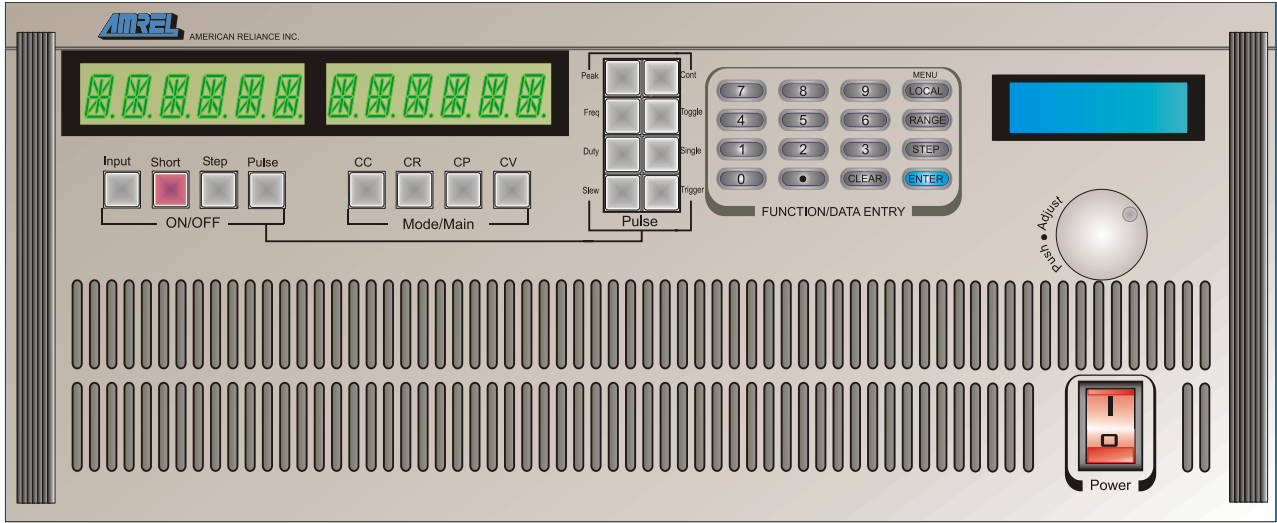

FIGURE 1.14 – PLA 4U FRONT PANEL

NOTE: All front panel descriptions are the same for 2U, 3U, 4U and 6U.

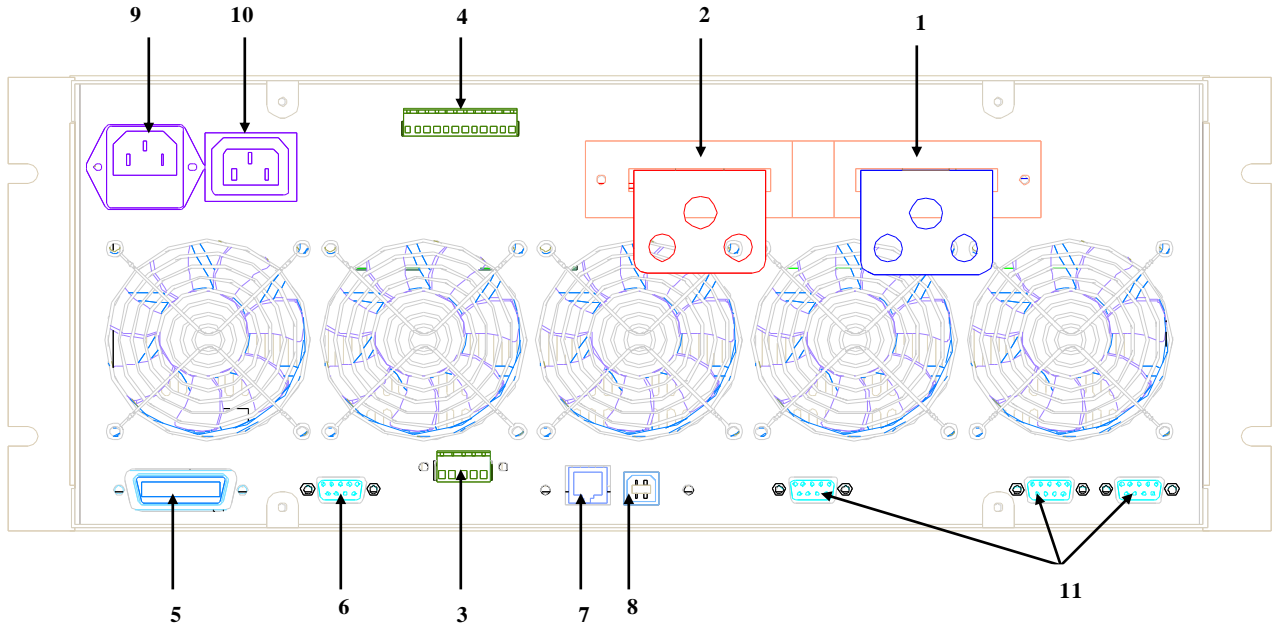

FIGURE 1.15 – PLA 4U REAR PANEL

Note: Please refer to the Specifications for detailed unit dimensions

1. (–) Negative input terminal. (one M12, two M6 screw threads)
2. (+) Positive input terminal. (one M12, two M6 screw threads)
3. Relay connector.
 - a. **RY_NC** Dry Contacts alarm: a fault alarm is declared if there is a loss of AC power or protections are triggered. The fault alarm outputs provide a normally closed relay configuration that provides user’s flexibility and isolation required to an external controller or an external alarm panel. The delay is 3 second

- b. **RY_CO** Relay Common. Provides the common (reference) connection only for RY_NC or RY_NO
 - c. **RY_NO** Dry Contacts alarm: a fault alarm is declared if there is a loss of AC power or protections are triggered. The fault alarm outputs provide a normally open relay configuration that provides user's flexibility and isolation required to an external controller or an external alarm panel. The delay is 3 second.
 - d. **RI_1** Remote Inhibited (RI) is used as an emergency switch to disable the system. RI can be connecting to a switch or an open collector device that shorts the RI pin to common (EGND) whenever it is necessary to disable input of the unit. Once RI is activated, it will turn off the dc output. In order to re-activate the unit, the connection between common and RI pin needs to be open again, and it will have 3 seconds delay.
4. External programming port.
 5. Connector, GPIB/IEEE-488.2.
 6. Connector, DB9 for RS232.
 7. Connector, RJ45 for Ethernet interface (LAN).
 8. Connector, USB.
 9. AC power inlet with external fuse holder.
 10. Interconnect AC power (future option)
 11. Interconnect cables (future option)

TWO: INSTALLATION

INTRODUCTION

This section provides recommendations and procedures for inspecting, installing, and testing the electronic load.

BASIC SETUP PROCEDURE

Use Table 2.1 to summarize the basic setup procedure and an overall view of the subsections. Use the procedure as a quick reference if you are familiar with the installation requirements for the programming electronic load. If you want more information, each step in the procedure refers to subsequent sections, which contain more details. Execute each step in the sequence provided.

| Step# | Description | Action | Reference |
|-------|--------------|---|--------------------------------------|
| 1 | Inspection | Perform an initial physical inspection of the load. | Inspection, cleaning, and packaging. |
| 2 | Installation | Install the instrument on bench or rack mount, ensuring adequate ventilation. | Location, mounting, and ventilation. |
| 3 | Input power | Connect AC input power | AC input power connection. |
| 4 | Test | Perform functional tests for CV mode, CC mode, and front panel controls. | Functional test. |
| 5 | Source | Connect the source. | Source connection. |
| 6 | Sense | Connect sensing lines. | Local and Remote sense. |

TABLE 2.1 BASIC SETUP PROCEDURE

INSPECTION, CLEANING, AND PACKAGING

- **INITIAL INSPECTION:** When you first receive your unit, perform a quick physical check.
 1. Inspect the instrument for cracks, scratches, broken switches, connectors, and display.
 2. Make sure there is not damage on the AC power cord; the AC input cover is installed properly and with the strain relief.
 3. Make sure there is no loose component in the unit that may cause by the long distance shipping.

If the unit is damaged, save all the packing materials and notify the carrier immediately.

- **MAINTENANCE:** No routine servicing of the electronic load is required except for periodic cleaning. Whenever the instrument is removed from operation, first use a low pressure air to blow dust from in and around components on the printed circuit board, clean the front panel with dry cloth or with a weak solution of soap and

water, clean the metal surfaces with naphtha or an equivalent solvent when used in high humidity. Then use the low-pressure air to blow it again.

RETURNING ELECTRONIC LOAD TO THE MANUFACTURER

Return Material Authorization Policy for warranty and non-warranty service:

Before returning a product directly to AMETEK Programmable Power Inc. you must obtain a Return Material Authorization (RMA) number and the correct manufactory Ship To: address. Products must also be shipped prepaid. Product shipments will be refused and returned at sender expense if they are unauthorized shipped without RMA # clearly marked on the outside of the shipping box, shipped "COD", or if they are shipped to the wrong location.

Please have the following information when contacting AMETEK Programmable Power for RMA #:

- 1- The model number of your product.
- 2- The serial number of your product.
- 3- Information about the failure and/or reason for the return.
- 4- A copy of your dated proof of purchase.
- 5- Firmware Version (Press "Clear" on the front panel)

When returning the product to AMETEK Programmable Power Inc.:

- 1- Package the unit safely, preferably using the original box and packing materials. Please ensure that your product is shipped fully insured in the original packaging or equivalent. **THIS WARRANTY WILL NOT APPLY WHERE THE PRODUCT IS DAMAGED DUE TO IMPROPER PACKAGING.**
- 2- Include the following information:
 - The RMA# supplied by AMETEK Programmable Power Inc. clearly marked on the outside of the box.
 - A return address where the unit can be shipped. Post office boxes are not acceptable.
 - A contact person, telephone, email where sender can be reached during work hours.
 - A brief description of the problem.

Ship the unit prepaid to the address provided by AMETEK customer service representative.

If you are returning a product from outside of the United States:

In addition to the above, you must include return freight funds if your instrument is out of warranty and are fully responsible for all documents, duties, tariff, and deposits.

PACKAGING FOR SHIPPING OR STORAGE

Instructions to prepare the instrument for shipping or storage.

- 1- When returning the unit or sending it to the service center, attach a tag to the unit stating its model number (available at the front panel label) and its serial number (available at the rear panel label). Give the date of purchase and an invoice number, if you have it, as well as a brief description of the problem.
- 2- For storage or shipping, repack the electronic load in its original box. If the original box is not available, seal the instrument in a plastic bag and pack it in a 200 lb. (90Kg) test corrugated cardboard carton large enough allow 3 inches (76.2mm) of cushioning material to surround the unit or use a material such as foam slabs or chips or an appropriate wooden crate used. Please consult with AMETEK shipping department for proper packing material and handling.
- 3- Label the package as shown in Figure 2.1.
- 4- Mark the address of the service center and your return address carton.

- 5- For storing, no more than two cartons high. The storage temperature should be between -40°C to 70°C.
- 6- For water cooled unit storing or shipping, must ensure no water or fluid is inside the unit.

| |
|---|
| <p>PROGRAMMABLE DC ELECTRONIC LOAD</p> <p>Model #: _____</p> <p>Serial #: _____</p> <p>FRAGILE – ELECTRONIC EQUIPMENT (PLEASE HANDLE WITH CARE)</p> |
|---|

FIGURE 2.1 SHIPPING OR STORAGE PACKAGE LABEL

LOCATION, MOUNTING, AND VENTILATION

Electronic load is designed for rack-mounted or bench top applications.

RACK MOUNTING INTALLATION

- 1- Use the integral rack-mount ears at both sides of the front panel to install the electronic load in a rack mount application.
- 2- Provide adequate support for the rear of the instrument without obstructing the ventilation inlets on the sides and rear of the unit. Use a support bar at the bottom or rear of the unit. Follow the rack-mount manufacturer’s instructions to install the support bar.

VENTILATION

Whether you place the electronic load in a rack or on a bench, allow cooling air to reach the ventilation inlets on the sides of the instrument and allow 4 in. (101.6mm) of unrestricted air space at the rear of the unit for the fan exhaust. Any ventilation space at the top and bottom of the supply will further lower internal operating temperatures.

FUSE REPLACEMENT

If the fuse is suspected to be defective, it should be inspected and, if necessary, replaced. To inspect or replace the fuse, please contact to AMETEK Programmable Power service department before performing the following steps:

- (1) Disconnect the AC line cord from the unit to reduce electrical shock hazard.
- (2) Remove the fuse by sliding out the fuse holder. The fuse holder is beneath the AC receptacle. Test the fuse for electrical continuity with an ohmmeter. Other fuse holder located at the printed circuit board.
- (3) If the fuse is found to be defective, replace it with a replacement fuse as specified in Table 2.2.
- (4) Replace the fuse in the fuse holder and re-install.
- (5) Re-install the cover and connect the AC power cord.



CAUTION

Use of any fuse other than the one specified could cause damage to the unit, pose a severe fire hazard, and will void the warranty.

| Model Type | Fuse Rating | Specification | Location |
|-----------------|-------------|---------------|---|
| PLW6K | 2.5A/250V | Slow Blow | External Fuse (Beneath the AC receptacle) |
| PLW9K | 4A/250V | Slow Blow | External Fuse (Beneath the AC receptacle) |
| PLW12K | 4A/250V | Slow Blow | External Fuse (Beneath the AC receptacle) |
| PLW18K | 4A/250V | Slow Blow | External Fuse (Beneath the AC receptacle) |
| PLW24K | 6.3A/250V | Slow Blow | External Fuse (Beneath the AC receptacle) |
| PLW36K | 6.3A/250V | Slow Blow | External Fuse (Beneath the AC receptacle) |
| PLW48K - Slave | 10A/250V | Slow Blow | External Fuse (Beneath the AC receptacle) |
| PLW48K - Master | 6.3A/250V | Slow Blow | External Fuse (Beneath the AC receptacle) |
| PLW60K - Slave | 10A/250V | Slow Blow | External Fuse (Beneath the AC receptacle) |
| PLW60K - Master | 6.3A/250V | Slow Blow | External Fuse (Beneath the AC receptacle) |
| PLA-2U | 2.5A/250V | Slow Blow | External Fuse (Beneath the AC receptacle) |
| PLA-3U | 4A/250V | Slow Blow | External Fuse (Beneath the AC receptacle) |
| PLA-4U | 6.3A/250V | Slow Blow | External Fuse (Beneath the AC receptacle) |
| PLA-6U | 8A/250V | Slow Blow | External Fuse (Beneath the AC receptacle) |
| PLA-8U-Master | 10A/250V | Slow Blow | External Fuse (Beneath the AC receptacle) |
| PLA-8U-Slave | 6.3A/250V | Slow Blow | External Fuse (Beneath the AC receptacle) |

TABLE 2.2 – FUSE REPLACEMENT SPECIFICATIONS

AC INPUT POWER CONNECTION

 **WARNING**

Disconnect AC power from the instrument before removing the cover. Even with the front panel power switch in the OFF position, live line voltages are exposed when the cover is removed and the AC cord is attached. Repairs must be made by experienced service technicians only.

NOTE: REMOVING THE TOP COVER OR DISASSEMBLING THE UNIT WILL VOID THE WARRANTY.

 **WARNING**

There is a potential shock hazard if the electronic load chassis and cover are not connected to an electrical ground via the safety ground in the AC input connector. Ensure that the electronic load is connected to a grounded AC outlet with the recommended AC input connector configured for the available line voltage.

AC INPUT CONNECTOR AND VOLTAGE SELECTION

 **CAUTION**

To prevent damage to the electronic load, turn off AC power to the unit before changing from one AC input voltage range to another. Example 115Vac to 230Vac.

eLoad series has an auto range selection function. This function allows you to connect to either low or high AC input voltage without making any adjustment to the unit.

AC INPUT CORD



WARNING

The AC input cord is the disconnect device for the electronic load. The plug must be readily identifiable to the operator. The input cord must be no longer than 3 m (9.84 feet).

The AC input cord we recommend is specified in Table 2.3, “AC Cord Specification”. If you require a special cord, call our sales representative.

| WIRE SIZE DIMENSIONS AWG | TYPE OF CONDUCTOR | RATINGS | LENGTH (feet) |
|-----------------------------|-------------------|---------|---------------|
| 16/3 | SJT | 105°C | 6 |
| 18/3 | SJT | 105°C | 6 |

TABLE 2.3 AC CORD SPECIFICATIONS

LOAD WIRING

To select wiring for connecting the load to the electronic load, consider the following factors:

- Insulation rating of the wire
- Current carrying capacity of the wire
- Maximum load wiring length for operation with sense lines
- Noise and impedance effects of the load lines

CURRENT CARRYING CAPACITY: As a minimum, load wiring must have a current capacity greater than the output current rating of the power supply. This ensures that the wiring will not be damaged even if the load is shorted. Table 2.4 shows the maximum current rating, based on 450 A/cm², for various gauges of wire rate for 105°C operations. Operate at the maximum current rating results in an approximately 30°C temperature rise for a wire operating in free air. Where load wiring must operate in areas with elevated ambient temperatures or bundled with other wiring, use larger gauges or wiring rated for higher temperature.

TABLE 2.4 CURRENT CARRYING CAPACITY FOR LOAD WIRING

| WIRE SIZE (AWG) | MAXIMUM CURRENT (A) |
|-----------------|---------------------|
| 2/0 | 303 |
| 1/0 | 247 |
| 1 | 192 |
| 2 | 155 |
| 4 | 97 |
| 6 | 61 |
| 8 | 36 |
| 10 | 21 |
| 12 | 16 |
| 14 | 10 |

REAR PANEL INLET AND OUTPUT PIPE INSTALLATION (For PLW Rack/Cabinet Only)

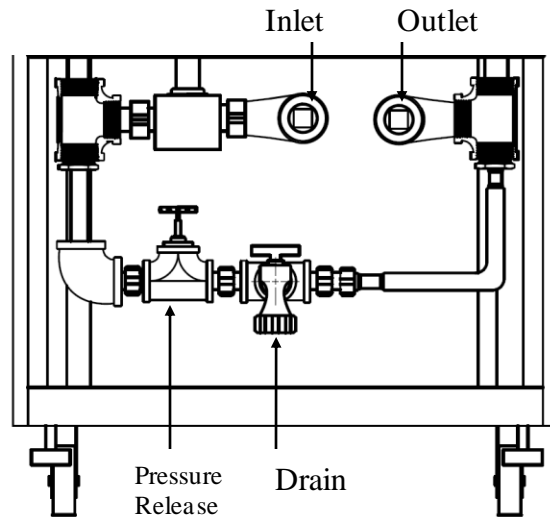

For PLW models greater than 4U height, unit will be ship in a cabinet with a pre-installed manifold system. Rear Panel diagram above illustrates positions of the cooling water inlet and outlet pipe as well as the drain faucet and pressure release faucet. Before filling the Load Bank with water, carefully read the following paragraphs for correct flow rate, water flow direction, and water pressure.



WARNING

Ensure the correct water flow direction and flow rate is set. Improper settings will extensively affect the power module heat dissipation capability. At all time, do not exceed the inlet water flow pressure limits and water pipe pressure specifications in order to prevent leakage or water pipe rupture.

Refer to the specification for pipe size, proper water flow rate and pressure limit for inlet water.

INLET WATER

Refer to attached drawing of Rear Panel diagram for the position of the inlet water pipe located in the bottom left center of the cabinet. Properly tighten the pipe with the correct wrench and do not over tighten the pipe causing damage to the threads.

Note: 150 micron filtration is recommended.

OUTLET WATER

Refer to attached drawing of Rear Panel diagram for the position of the outlet water pipe located in the bottom right corner of the cabinet. Properly tighten the pipe with the correct wrench and do not over tighten the pipe causing damage to the threads.

WATER PRESSURE

Before applying water to the Load Bank, separately turn-off the drain faucet (clockwise direction) and pressure release faucet (clockwise direction). Gradually let the water flow and check for any leaks in the pipe and lines. If any leaks are found, relieve the pressure and tighten the pipe connector immediately with the proper tool.

Note: The load must have water flow in order to work properly and the water pressure must be less than 80 PSI.

RECOMMENDED WATER PIPING INSTALLATION FOR PLW SERIES

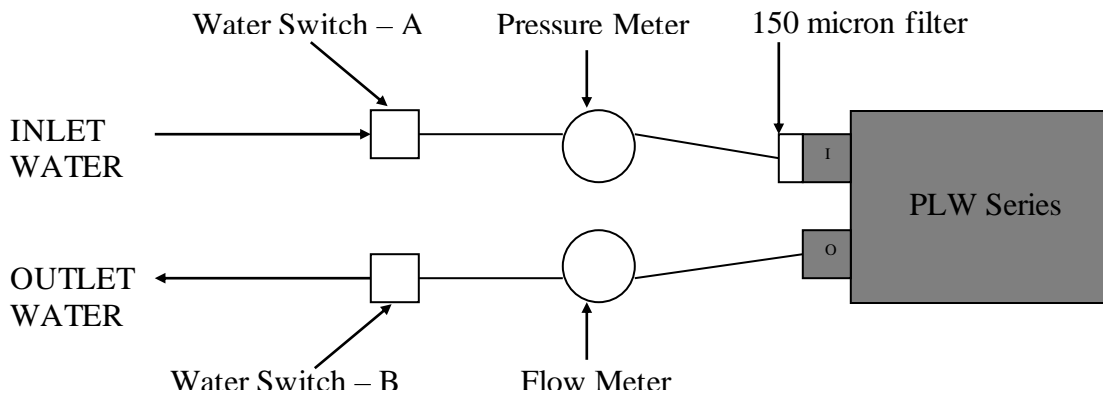

FIGURE 2.2 PIPING AND COOLANT INSTALLATION

Important Precautions:

1.

| PLW height | Pipe Size |
|------------|-----------------------|
| 2U | 3/8" NPT |
| 4U | 1/2" NPT |
| > 4U | check model datasheet |

2. It is recommended that the system be check for water leaks before operation.
 - a. Check for water leaks by closing Water Switch – B.
 - b. Then opening Water Switch – A.
 - c. Turn the Load’s power ON and check for leaks (the power of the PLW must be ON in order for water flow into the load).
3. Flow Meter’s inlet and outlet should be equal or greater than PLW pipe size.
4. Install a 150-micron filter at the water inlet.
5. Water pressure must be less than 80 PSI in order for the valve to work properly.
6. Never allow to flow from outlet to inlet.
7. Water temperature should be between 5°C and 30°C.
8. Use only non-corrosive type of liquid for cooling with a neutral pH level of 7. (We suggest using distilled or de-ionized water)
9. Water viscosity must be less than 50 CST.

Important Note: Please refer to Appendix B for Heat Sink Temperature VS. GPM Curve to help determine the GPM level for your system

COOLANT WITH ANTI-FREEZE (GLYCOL) PRECAUTIONS

Cooling liquids containing Anti-Freeze (Glycol) will decrease the thermal efficiency of the PLW cooling system by reducing the cooling efficiency and increasing the viscosity of the coolant. To counteract the lowered heat dissipation, the GPM must be increased to maintain proper cooling of the system (refer to specific PLW model datasheet for requirement). Increased glycol levels will affect the power handling capability of the unit, please consult with the glycol's manufacture for detail characteristic of specific glycol mixture affecting flow rate, pressure drop, pH value, viscosity, etc.

LOAD WIRING LENGTH FOR OPERATION WITH SENSE LINES

For applications that use remote sensing, you must limit the voltage drop across each source line. We recommend that you use the larger load wiring or ensure a smaller voltage drop (1V typical max.) along the wire, although the remote sensing will compensate for voltage drops up to 1% of V_{MAX} in each line. Please see the following table:

| Max Rated Voltage | Max Voltage Drop Compensation |
|--------------------------|--------------------------------------|
| 100 V | 1 V |
| 200 V | 2 V |
| 300 V | 3 V |
| 400 V | 4 V |
| 500 V | 5 V |
| 600 V | 6 V |
| 700 V | 7 V |
| 800 V | 8 V |

TABLE 2.5 VOLTAGE DROP COMPENSATION

NOISE AND IMPEDANCE EFFECTS

To minimize noise pickup or radiation, use shielded pair wiring or shortest possible length for source wires. Connect the shield to the chassis via a rear panel mounting screw. Where shielding is impossible or impractical, simply twisting the wires together will offer some noise immunity. When using local sense connections, the user must use the largest practical wire size to minimize the effects of load line impedance on the regulation of the load.

LOAD CONNECTIONS

The electronic load is designed with an air-cooling/water-cooling system that provides airflow/water flow through the heat sink to remove the heat generated by the Power MOSFETs. To obtain efficient heat exchange rate between heat sink and power MOSFETs, the user needs to follow the instruction outlined below to ensure the heat is removed from heat sink properly to prevent excess heat from accumulating in the power module. Under high power handling applications or increased temperature operation, heat dissipation becomes a key factor in determining the reliability of the overall unit.

INPUT TERMINAL



WARNING

For the safety of personnel and to prevent electrical shock due to high voltage, do not come in contact or obstruct the input terminals. Refer to the next page diagram, for the location of the input terminals.



WARNING

Never touch the input terminal when your hands are wet. Dry your hands first before operate the instrument.

Observe the maximum current handling capability of the power cables from DUT to the Load Bank. Please refer to Table 2.4 for higher current rating cables. Observe the maximum input current and voltage of the terminals. Do not underrated the cable, excessive current will cause the temperature to increase and cause melting of the insulation rubber of the terminal and cable insulation sleeves resulting in input cable shorts.

For the high current applications, large diameter power cables are necessary to prevent load oscillation. The power cables should be as short as possible to reduce inductance from the power cable and cause oscillation between power sources and the load unit.

INPUT TERMINAL CONNECTOR



WARNING

There is a shock hazard at the load when using an electronic load with a rated output greater than 40V. To protect personnel against contact with hazardous voltages, ensure that the load, including connections, has no live parts, which are accessible. Also ensure that the insulation rating of the source wiring and circuitry is greater than or equal to the maximum output voltage of the electronic load.



CAUTION

When making connections to the bus bars. Ensure that each terminal's mounting hardware and wiring assembly are placed to avoid touching the other terminal and shorting the electronic load input. Heavy connecting cables must have some form of strain relief to avoid loosening the connections or bending the bus bars.

LOCAL SENSE CONFIGURATION

When the Electronic Load is strapped for local sensing, an unavoidable voltage drop is incurred in the load leads and this adds to the load regulation. Hence, local sensing is usually used in applications where the lead lengths are relatively short, or load regulation is not critical. Local or remote sense can be set by accessing: **MENU**→**LOAD CONTROL**→**REMOTE SENSE** → **LOCAL** and pressing enter button to confirm.

To meet safety requirement, load wire size should be large enough to carry electric current of the source to the Electronic Load without overheating. Stranded, copper wires are recommended. The wires should be large enough to limit the voltage drop to less than 1V per lead. Refer to Table 2.4 for proper wire size selection. Input wire connections are made to the "+" and "-" terminals on the rear panel of the Load.

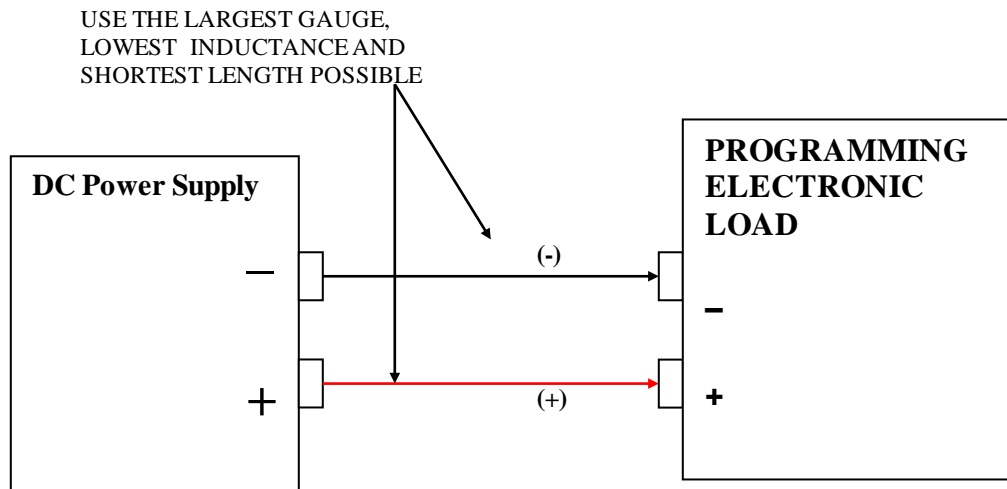

FIGURE 2.3 LOCAL SENSE CONFIGURATIONS

REMOTE SENSE CONFIGURATION



CAUTION

Turn off the electronic load before making any connections on the rear panel terminal block.

In remote sense operation, the electronic load senses the input at output terminals of the source. As shown in figure 2.4, the remote sense terminals of the Load are connected to the output of the source. Remote sensing compensates for the voltage drop in applications that require long leads. It is useful in any operating mode requiring accurate voltage read back. Load leads should be bundled or tied together to minimize inductance.

Note: Use the largest gauge size, lowest inductance and shortest possible length for the sources line.

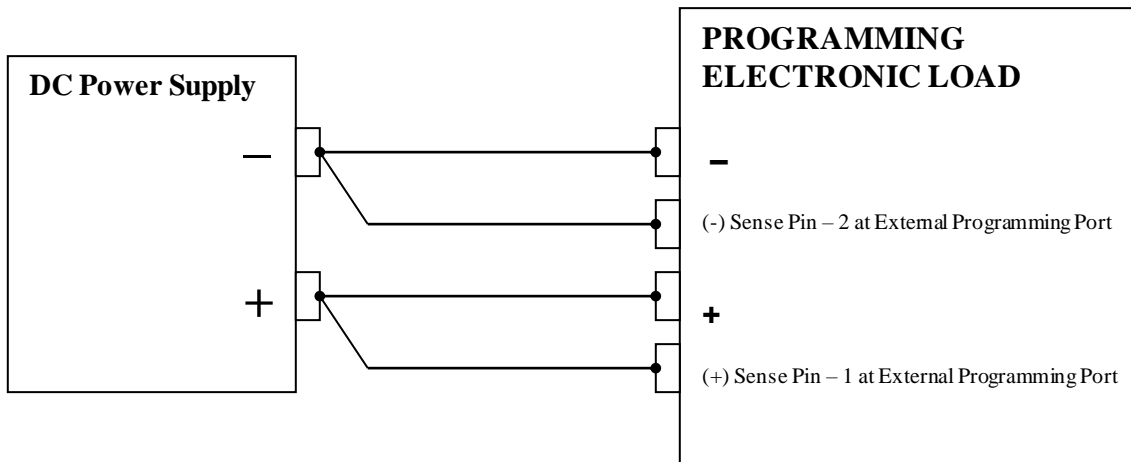

FIGURE 2.4 REMOTE SENSE CONFIGURATIONS

PARALLEL CONNECTIONS

The electronic loads can be connected in parallel to increase power dissipation and allow current sharing. Numerous Electronic Loads can be directly paralleled in CC or CRM or CP mode, with the proper setup and configuration. Parallel operation in all operating modes is recommended when using the external control port to send in an in-sync external control signal. By utilizing an external control signal and ensuring all eLOAD are identical in model, operating range and mode; synchronized parallel eLOAD operation can be achieved, providing optimized performance and results. As a rule of thumb, parallel Load Bank operation is for current sharing amongst a number of loads, to ease the overpower restrictions of a single load. In short, parallel operation increases the power handling capability for high current and high voltage applications. Each Electronic Load will dissipate the power it has been programmed for. If two Electronic Loads are connected in parallel, with Load 1 programmed for 10 A and Load 2 programmed for 15 A, the total current drawn from the source is 25 A. In another scenario, if Load 1 is programmed for 0.5 ohm and Load 2 is programmed for 0.5 ohm, the total equivalent resistance of the two paralleled Loads is 0.25 ohm. eLOAD (with firmware version 2.86 or later) offers an advance control of parallel operation; please refer to Appendix B section 11 for “Master-Slave Parallel Operation” step-by-step procedures and important details.

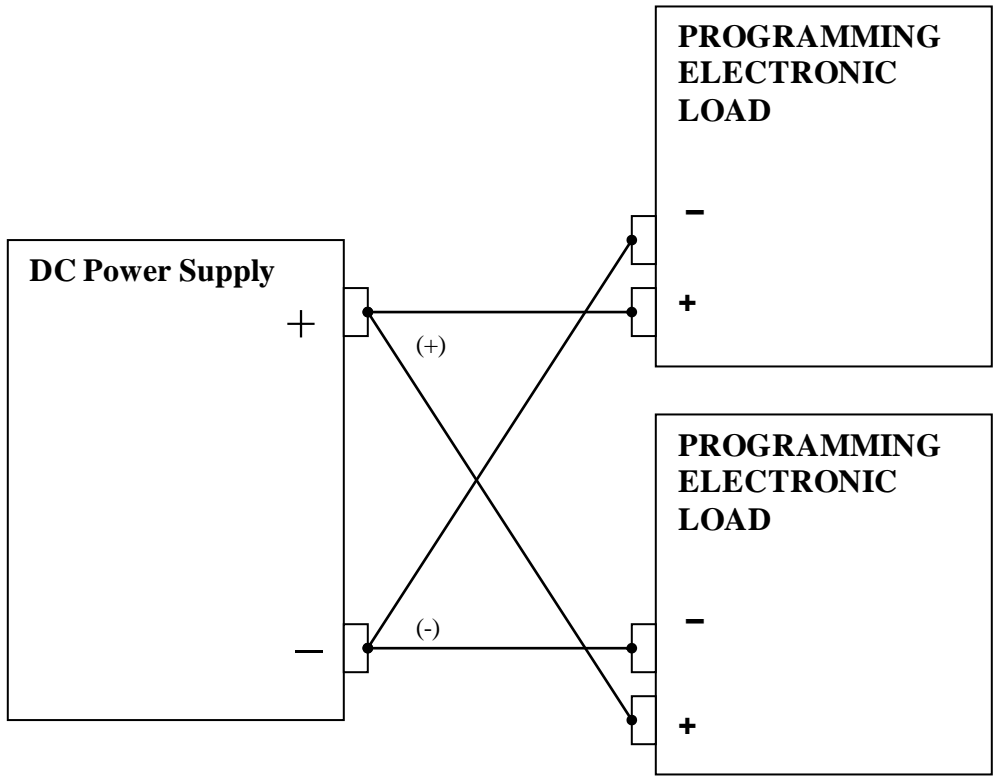

FIGURE 2.5 PARALLEL CONFIGURATION

TRIGGER OPERATION

Figure 2.5 depicts the method of triggering the Electronic Loads. The TRIGOUT signal of the Electronic Load is connected to the Trigger input of the DMM. Additional instruments can be daisy chained to a DMM in the same manner. Once the preset settings of the instruments have been programmed, one trigger signal can simultaneously set all instruments to their transient settings.

Note: Trigger Operation is Negative-Edge Triggered

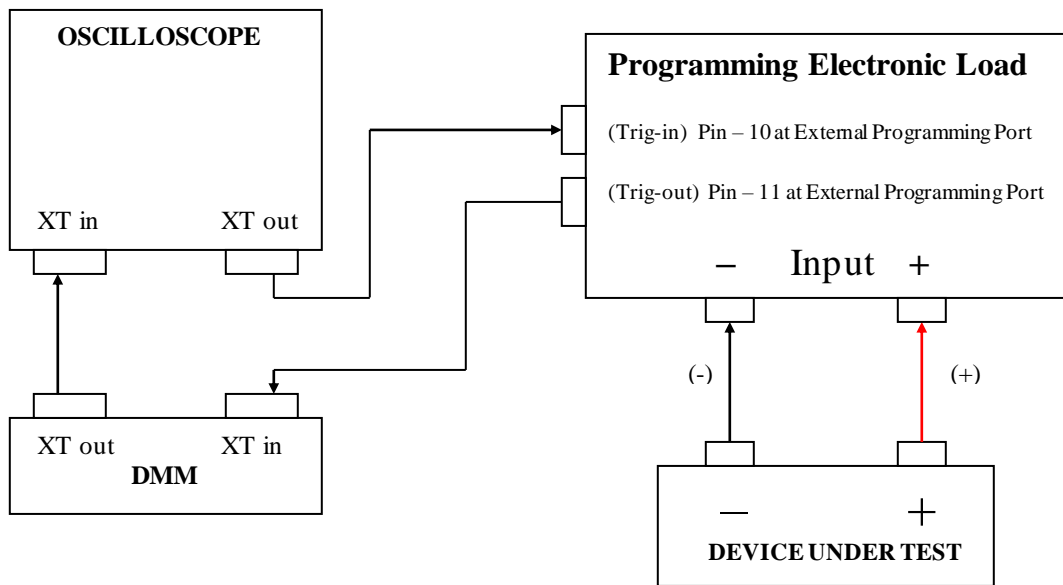

FIGURE 2.6 TRIGGER CONFIGURATION

ZERO-VOLT LOADING CONNECTION

The Electronic Load can be connected in series with voltage sources that can accommodate the minimum operating voltage and line voltage drop so the Electronic Load can test the devices at its full current capacity down to a zero-volt level.

Important Notes:

1. The boost power supply used for Zero-Volt Load Operation must handle up to the maximum operating current of the application.
2. The power rating of the Load Bank will decrease based on the amount of power dissipated at the boost power supply.
3. A protective diode rated for the maximum operating current of the application will need to be placed across the power terminals of the DUT.
4. A boost power supply with minimal noise specification is recommended for zero-volt load operation.

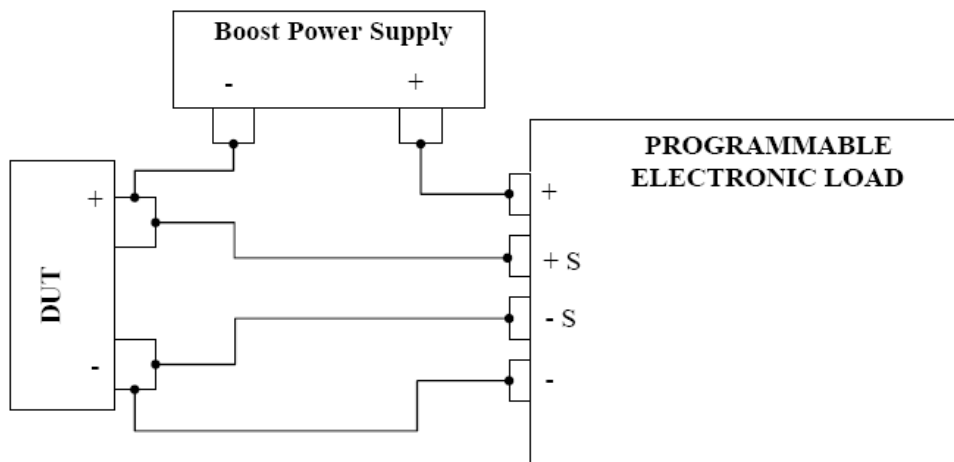

FIGURE 2.7 ZERO-VOLT LOADING

THREE: LOCAL OPERATION

INTRODUCTION

The programmable electronic load provides powerful control capabilities, which consist of four operating modes CV/CC/CR/CP. To complement and enhance these features, an internal transient generator is provided to simulate dynamic operations. The Transient operation provides three programmable features, Transient frequency, Transient duty cycle, and Transient slew rate. These features provide the user with precise and efficient control of the powerful eLoad to handle the most diverse array of testing applications.

The programmable electronic load provides additional functions and capabilities, such as 256 point step programmable in four user defined profiles, Cross Mode and Cross Range Operation and Short Operation. For battery testing, we provide the “C” operand to help user in testing battery parameters without troublesome calculations.

The wide range of operating modes, accurate specifications, and advanced features provide the electronic load with increased flexibility to work with different types of DUT and power source. Protection features such as Programmable OVP, OCP, OPP, redundant OTP and hardware OP Protection are provided to protect the electronic load under different load conditions. Please refer to the specifications to check the maximum input current, voltage, and power range in order to safely test and obtain the best results.

Note: Protection Mode will shut off the Load Bank input, please take the necessary precaution.

VOLTAGE AND CURRENT METERING INFORMATION

The programmable electronic load uses a DAC with a guaranteed 14-bit resolution in the metering system and is active once the unit is turn on. With sophisticated control circuits, the load can measure full-scale input voltages and currents with Auto-Scaling capability. For example, when low voltages levels are applied, the display's decimal point will move to accurately display the lower value. The same is true for the larger input values, the decimal will move to accurately display the higher value. Refer to the Specifications for more programming and read back information.

OPERATING STATUS INFORMATION

All operating status information will be displayed when they become active. For example, when the Over-voltage is tripped, the LCD module will display OVP.

| SYMBOL | TYPE | DESCRIPTIONS |
|--------|---------|------------------------------|
| UNR | WARNING | unregulated |
| OVP | ALARM | over voltage protection |
| UVP | ALARM | under voltage protection |
| OCP | ALARM | over current protection |
| UCP | ALARM | under current protection |
| OPP | ALARM | over power protection |
| UPP | ALARM | under power protection |
| OTP | ALARM | over temperature protection |
| UTT | WARNING | under temperature protection |
| OSC | ALARM | oscillation |
| LV | WARNING | low voltage |
| OV | ALARM | over voltage |
| OC | ALARM | over current |
| OP | ALARM | over power |
| RCP | ALARM | reverse current protection |
| RSF | ALARM | remote sense fault |
| UVL | WARNING | under voltage lockout |
| INT | ALARM | interlock |



WARNING

Do not deliberately try to trip the OVP circuit on when performing battery-testing applications. When an Over-voltage condition occurs, the electronic load will try to sink more current in order to drop the input voltage source. In other words, the input source is supplying more power than the electronic load is capable of handling. By trying to trip the Over-voltage circuit, you may severely damage both the input source and the load.

LOCAL AND GPIB OPERATION INFORMATION

When the programmable electronic load is first turned on, the LCD will display LCL for local communication (via keypad). When the electronic load is communicating via GPIB, USB, Ethernet or RS-232 remote control operation, the LCD module will display GPIB/ETHER/RS-232/USB to inform the user that the keypad is disabled, and the load is being controlled remotely. Pressing the LOCAL key will change status from remote access to local operation.

MODE MENU OPERATION AND RANGE SETTING

The eLOAD provides a wide range of input operating modes CV/CC/CR/CP and range operation (Manual Low/Manual Middle/Manual High/Automatic). The user is capable of activating any mode during the operation of the unit; however, careful attention needs to be adhered to prior to entering the programming values for each operating mode and correct range.



WARNING

The Mode HOT Keys play an important role in switching operating mode (CV, CC, CR, and CP) and the “Range” selection key allows easy range switching from manual (all ranges) to auto. By switching to other modes/range, the input will shut off. A cross mode and cross range feature is offered on the eLoad that will keep the input on when switching between different modes and ranges. An important precaution is to make sure the proper settings are utilized for the designated range. For example, if a PLA800-120-150 eLoad is operating in CCH mode at 100A, and the mode is crossed over to CPL, the input will shut off and display “OC”. The reason for the protection shutdown is due to the maximum current in CPL is 15A, and 100A in that range is too high. To prevent from protection shutdown of the eLoad, ensure proper voltage and current settings before using the cross mode and cross range feature.

TO SELECT THE MANUAL MODE AND RANGE, SIMPLY FOLLOW THE PROCEDURE:

1. Press the Range key, and use the encoder to select between manual low, manual middle, manual high or automatic. Select manual low and press enter.
2. Select the desired mode by pressing the corresponding hot key. Press the CC hot key.
3. Now the operating range is CC mode in low range.

TO SELECT THE AUTOMATIC MODE AND RANGE, SIMPLY FOLLOW THE PROCEDURE:

Example: If 300A is maximum current = high range, then 30A = low range.

1. Press the Range key, and use the encoder to select between manual low, manual middle, manual high or automatic. Select automatic and press enter.
2. Select the desired mode by pressing the corresponding hot key. Press the CC hot key.
3. Now the operating range is CC mode in automatic range.

MAIN LEVEL LOCAL OPERATION

There are three levels of operations: MAIN level, TRANSIENT level and TRIGGERED level. The MAIN level operation and its associated set of values are for static operation. TRANSIENT and TRIGGERED operations are for various types of dynamic applications.

The main level programming values for the four different operating modes are entered in the same manner; the difference is the unit of measurement for each operating mode. For example, CV mode is in V (Voltage) unit, CC mode is in A (Amps) unit, CR mode is in Ω (Ohm) unit and CP mode is in W (Watts) unit.

The CV, CC, CP and CR modes have more than one operating range. The low ranges provide better resolution for low settings. Each mode's range is selected by pressing the "RANGE" key. See example below.

Example 1.

1. Press the "CC" Hot Key. Select the programming range by pressing "Range," and turn the encoder to the desired range (set to low range). Let's assume main level programming value indicates 10 amps, in the low range. Try to set the programming value to 15.0 Amps.
2. Press and hold the encoder and wait for a numerical key entry for a new value. On the second line of the LCD module the following format will be displayed: CURR = 10.000A
3. Enter the following numerical key sequence "1", "5", "." and "0" or another current value below the max rated current.
4. If the number that was entered is not correct, then press the "CLEAR" key to erase the wrong entry and repeat step 3.
5. Press the "ENTER" key to complete the entry operation.
6. If the entered value is over the maximum rating of the current range, then the eLOAD LCD will display "Overflow", and allow the user to enter another value. Either change the entered value to a number that is within the current range or select the correct range by pressing the RANGE key as indicated in step 1.

Example 2.

1. Assume that the eLOAD is in the CP mode and main level programming value indicates 40 Watts. Try to set the programming value up to 50.0 Watts.
2. Press the "CP" Hot Key. Select the programming range by pressing "Range," and turn the encoder to the desired range (set to low range). Press and hold the encoder and wait for a numerical key entry for a new value. On the second line of the LCD module the following format will be displayed: POWER = 40 W
3. Enter the following numerical key sequence "5", "0", "." and "0".
4. If the number that was entered is not correct, then press the "CLEAR" key to erase the wrong entry and repeat step 3.
5. Press the "ENTER" key to complete the entry operation.
6. If the entered value is over the maximum rating of the power range, then the eLOAD LCD will display "Overflow", and allow the user to enter another value. Either change the entered value to a number that is within the current range or select the correct range by pressing the RANGE key as indicated in step 1.

After the entry steps have been completed, the new main level programming values will immediately be in effect and the eLoad will return to the metering mode.

ENCODER OPERATION

| BUTTON or SETTING | ENCODER ACTION | FUNCTION |
|--|-----------------------|--|
| Main Level Setting Screen in Main Value Edit Mode | Press & Hold | Change Input Value |
| | Tap | Change Decimal Position |
| | Rotate Left | Decrement Value |
| | Rotate Right | Increment Value |
| Main Level Setting Screen With Input On | Press & Hold | Modify/Enter Value |
| | Tap | Modify/Enter Value |
| | Rotate Left | Decrement Value (real-time) |
| | Rotate Right | Increment Value (real-time) |
| PEAK Hot Key Pressed | Press & Hold | Change Input Value |
| | Tap | Change Decimal Position |
| | Rotate Left | Decrement Value |
| | Rotate Right | Increment Value |
| DUTY Hot Key Pressed | Press & Hold | Modify/Enter Value |
| | Tap | Change Decimal Position |
| | Rotate Left | Decrement Value |
| | Rotate Right | Increment Value |
| SLEW Hot Key Pressed | Press & Hold | Make Selection/Modify/Enter Value |
| | Tap | Change Decimal Position |
| | Rotate Left | Scroll Through Selection/Increment Value |
| | Rotate Right | Scroll Through Selection/Decrement Value |
| MENU Button Pressed | Press & Hold | Select Menu Option |
| | Tap | Exit to Previous Menu |
| | Rotate Left | Scroll Through Selection |
| | Rotate Right | Scroll Through Selection |
| RANGE Button Pressed | Press & Hold | Select Mode & Range Type |
| | Tap | Select Mode & Range Type |
| | Rotate Left | Scroll Through Selection |
| | Rotate Right | Scroll Through Selection |
| STEP Button Pressed | Press & Hold | Make Selection/Modify/Enter Value |
| | Tap | Change Decimal Position |
| | Rotate Left | Scroll Through Selection/Increment Value |
| | Rotate Right | Scroll Through Selection/Decrement Value |

TABLE 3.1 ENCODER OPERATION

MENU FUNCTION

The MENU function allows the user to set the different system configurations such as GPIB, Stepping, Max/Min setting, Protection, and Calibration. The vast array of features and configurations allow the eLoad to accommodate different situations or testing configurations. The Local/Menu function is the start of the tree structure, which enables the user to branch.

Press **MENU** key:

* Use **↵** to select the next menu setting then press ENTER key to enter the selected menu.

* Use **CLEAR** key to back space or to correct the wrong value.

A: LOAD CONTROL ↵ B: PROFILE ↵ C: DISPLAY ↵ D: SYSTEM ↵
E: AUTHENTICATE

A: Load Control Menu - press ENTER key:

* Turn the encoder **↵** to select the next menu setting then press ENTER key to enter the selected menu.

* Use **CLEAR** key to back space or to correct the wrong value.

1: STEP PARAM. ↵ 2: MEASURE SENSE ↵ 3: PORT 0 ↵ 4: EXT. CONTROL ↵ 5: SHORT CONTROL ↵ 6: CROSS MODE ↵ 7: CROSS RANGE ↵ 8: TRIGGER ↵ 9: PROTECTION ↵ 10: MAX/MIN LIMIT ↵ 11: CAL PARAM. ↵ 12: OSCILLATE ↵ 13: BOOT INPUT

1. STEP PARAM.----- press ENTER key, use **↵** to select number of Step COUNT then press ENTER. (0 → infinite)
2. MEASURE SENSE--press ENTER key, use **↵** to select LOCAL / REMOTE sense then press ENTER.
3. PORT0 -----press ENTER key, use **↵** to enables or disables digit port the press ENTER.
4. EXT. CONTROL----press ENTER key, use **↵** to select ON / OFF then press ENTER.
5. SHORT CONTROL--press ENTER key, use **↵** to select ON / OFF then press ENTER.
6. CROSS MODE-----press ENTER key, use **↵** to select INPUT OFF / INPUT REMAIN then press ENTER.
7. CROSS RANGE----- press ENTER key, use **↵** to select INPUT OFF / INPUT REMAIN then press ENTER.
8. TRIGGER-----press ENTER key, use **↵** to select Source (Held, BUS, EXTERNAL, ETHERNET) / DELAY (in milli-second), then press ENTER.
9. PROTECTION-----press ENTER key,

1: OV PROTECTION ↵ 2: UV PROTECTION ↵ 3: OC PROTECTION ↵ 4: UC PROTECTION ↵ 5: OP PROTECTION ↵ 6: UP PROTECTION ↵ 7: V-ON CONTROL

1. OV PROTECTION-----press ENTER key, input the STATE/LIMIT/DELAY then press ENTER.
 2. UV PROTECTION-----press ENTER key, input the STATE/LIMIT/DELAY then press ENTER.
 3. OC PROTECTION-----press ENTER key, input the STATE/LIMIT/DELAY then press ENTER.
 4. UC PROTECTION-----press ENTER key, input the STATE/LIMIT/DELAY then press ENTER.
 5. OP PROTECTION-----press ENTER key, input the STATE/LIMIT/DELAY then press ENTER.
 6. UP PROTECTION-----press ENTER key, input the STATE/LIMIT/DELAY then press ENTER.
 7. V-ON CONTROL-----press ENTER key, input the STATE/V-ON THRESHOLD then press ENTER.
10. MAX/MIN LIMIT---press ENTER key,

1: MAX VOLTAGE ↵ 2: MIN VOLTAGE ↵ 3: MAX CURRENT ↵ 4: MIN CURRENT ↵ 5: MAX RESISTOR ↵ 6: MIN RESISTOR ↵ 7: MAX POWER ↵ 8: MIN POWER

1. MAX VOLTAGE-----press ENTER key, input the maximum voltage then press ENTER
 2. MIN VOLTAGE -----press ENTER key, input the minimum voltage then press ENTER.
 3. MAX CURRENT-----press ENTER key, input the maximum current then press ENTER.
 4. MIN CURREN-----press ENTER key, input the minimum current then press ENTER.
 5. MAX RESISTANCE---press ENTER key, input the maximum resistance then press ENTER
 6. MIN RESISTANCE----press ENTER key, input the minimum resistance then press ENTER
 7. MAX POWER----- press ENTER key, input the maximum power then press ENTER
 8. MIN POWER----- press ENTER key, input the minimum power then press ENTER
11. CAL. PARAM.----press ENTER key, input the MEASURE LOW/ MEASURE HIGH / TRAN. OFFSET, then press ENTER.

1: LOW MEAS POINT 00 2: HIGH MEAS POINT 00 3: TRANS OFFSET

- 1: LOW MEASURE POINT--press ENTER key, set the low measure count value then press ENTER.
- 2: HIGH MEASURE POINT--press ENTER key, set the high measure count value then press ENTER.
- 3: TRANSIENT OFFSET---- press ENTER key, set the transient offset count then press ENTER.

12. OSCILLATE-----press ENTER key, select the OSC. CONTROL/ OSC. DELAY, then press ENTER.
13. BOOT INPUT-----press ENTER key, use 00 to select ON / OFF then press ENTER.

B: Profile Menu - press ENTER key:

- * Use 00 to select the next menu setting then press ENTER key to enter the selected menu.
- * Use CLEAR key to back space or to correct the wrong value.

1: RECALL 00 2: SAVE 00 3: RESET

1. RECALL-----press ENTER key, use 00 to select the profile 0/1/2/3 then press ENTER to recall.
2. SAVE-----press ENTER key, use 00 to select the profile 0/1/2/3 then press ENTER to save.
3. RESET-----press ENTER key, then press ENTER to reset.

C: Display Menu - press ENTER key:

- * Use 00 to select the next menu setting then press ENTER key to enter the selected menu.
- * Use CLEAR key to back space or to correct the wrong value.

1: Meter Mode 00 2: 'C' Value

1. METER MODE---press ENTER key, use 00 to select display mode (V+I, V+P, V+C, V+R, I+P, I+C, I+R, R+P, R+C, P+C, V+T, I+T, R+T, P+T, C+T) then press ENTER.
2. 'C' Value-----press ENTER key, then input the C value in Ampere.

D: System Menu - press ENTER key:

- * Use 00 to select the next menu setting then press ENTER key to enter the selected menu.
- * Use CLEAR key to back space or to correct the wrong value.

1: GPIB ADDRESS 00 2: RS-232 SPEED 00 3: SYNTAX MODE 00 4: EOS CODE 00 5: BUZZER 00 6: PANEL LOCK 00 7: ETHERNET

1. GPIB ADDRESS--press ENTER key, use 00 to set the GPIB address (0 – 31) then press ENTER.
2. RS-232 SPEED---press ENTER key, use 00 to set the BAUD RATE (2400 – 115200) then press ENTER.

3. SYNTAX MODE--press ENTER key, use ⓪ select the syntax mode (PEL or PLW/PLA) then press ENTER
4. EOS CODE-----press ENTER key, use ⓪ to set end of interface code then press ENTER.
5. BUZZER-----press ENTER key, use ⓪ to select ON / OFF then press ENTER.
6. PANEL LOCK
7. ETHERNET-----press ENTER key, use ⓪ to select ADDRESS/NETMASK/GATEWAY; press ENTER.

E: Authenticate Menu - press ENTER key:

- * Use ⓪ to select the next menu setting then press ENTER key to enter the selected menu.
- * Use CLEAR key to back space or to correct the wrong value.

| |
|--|
| 1: SERIAL NO. ⓪ 2: INTERFACE ⓪ 3: CODE |
|--|

1. SERIAL NO.-----press ENTER key. Serial NO. should start with 000B87xxxxxx.
2. INTERFACE-----press ENTER key. GPIB/ETHER/USB should be display according to customer's order.
3. CODE-----press ENTER key, Input the code from AMETEK, then press ENTER.

LOAD CONTROL MENU

STEP PARAMETERS

Selects the number of Step Count (0 - 65535 & infinity) and the different Step Modes (STEP, STEP AUTO, and STEP ONCE)

MEASURE SENSE

This feature allows selection of local sense or remote sense of voltage. Remote sense allows voltage to be measured at a different sense point than the bus bars to prevent large voltage drops over lengthy wires. If the voltage reading between the remote sense and bus bar differ by greater than a set threshold, Remote Sense Fault (RSF) will trigger and shutdown the input.

Note: The eLoad's voltage measuring points (positive and negative) can be configured to two locations. One is from the power input terminals called Local; the other is from the remote sense terminal block in the rear panel called Remote (Remote option is only available in certain models). The purpose of the Remote sense is for more accurate voltage measurement when longer cables are used (large voltage drop caused by long cables).

MEAS. BUFFER STABLE READ BACK

For AC coupled DC input signals, the read back meter may display an unstable reading. Do not be alarmed, the read back reading update rate can be slowed down for a more stable reading. Only 8 or 16 meas.buffer setting is suggested to be selected, to ensure the correct measurements are updated properly.

PORT 0

A general purpose output port that generates a TTL compatible signal; active high (5V) when port is on and inactive low (0V) when port is turned off. The PORT 0 feature can be used to control external devices such as a DC Contactor or a relay. To enable PORT 0, simply follow LOAD CONTROL → PORT 0 → ON.

EXTERNAL CONTROL

Basic Functionality:

The external control function allows the eLOAD's maximum range (L/M/H) voltage, current, power and resistance to be scaled from 0 to 10 Volts. The external voltage signal will control the eLOAD to operate at the corresponding current/voltage/resistance/power. Please see the table below for further details.

Note: AMREL specifications guarantee a 0 - 10 V External Programming Voltage. If an application requires a positive and negative voltage swing (V_{AC}), the External Programming port can support up to $10 V_{AC} \geq \text{Ext } V_{AC} \geq -1 V_{AC}$.

| EXT_CTRL Voltage | Current Range | Range Current Rating | Main Current Value |
|------------------|---------------|----------------------|--------------------|
| 0 V | L | 6 A | 0 A |
| 5 V | L | 6 A | 3 A |
| 10 V | L | 6 A | 6 A |
| 0 V | M | 30 A | 0 A |
| 5 V | M | 30 A | 15 A |
| 10 V | M | 30 A | 30 A |
| 0 V | H | 60 A | 0 A |
| 5 V | H | 60 A | 30 A |
| 10 V | H | 60 A | 60 A |

Setup Diagram

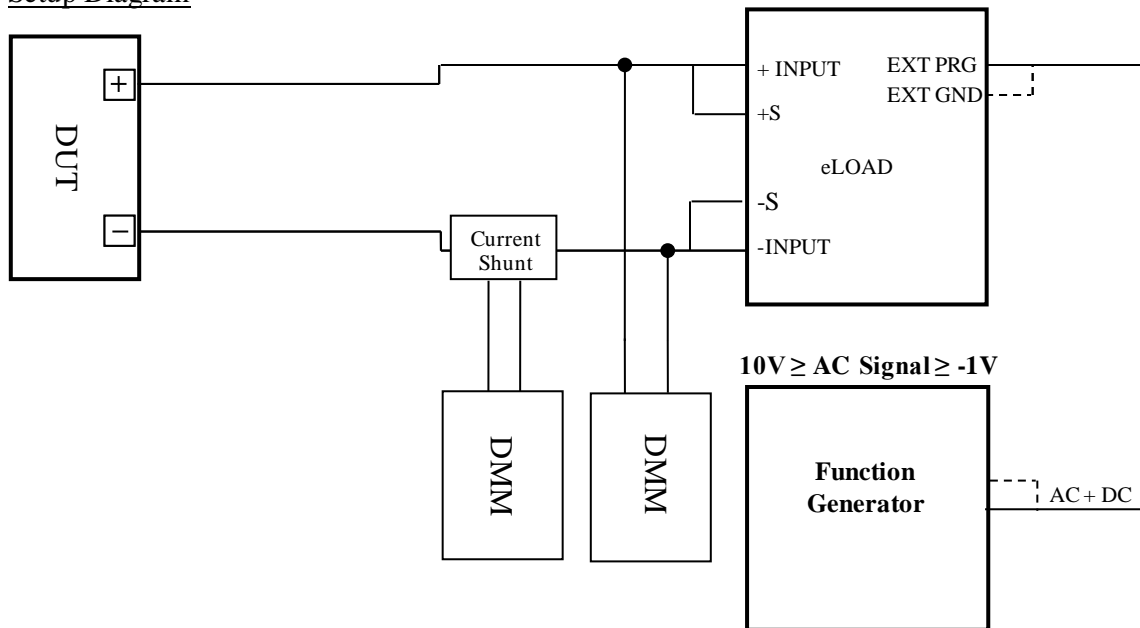

FIGURE 3.2 EXTERNAL PROGRAMMING SETUP

SHORT CONTROL

Enables/Disables Short Control.

CROSS MODE

Toggles between Input Off/Input Remain. Input remain will allow input to remain on when switching modes.

CROSS RANGE

Toggles between Input Off/Input Remain. Input remain will allow input to remain on when switching ranges.

TRIGGER SOURCE

Select the trigger source for transient operation. Please refer to the following table for different trigger sources and the available triggering methods.

| TRIGGER SOURCE | TRIGGER INPUT | | | | |
|----------------|---------------|--------------|----------|------------------|-------------|
| | EXT_TRG_IN | *TRG Command | Ethernet | TRIG:IMM Command | Front Panel |
| EXTERNAL | O | X | X | O | O |
| BUS | X | O | X | O | O |
| ETHERNET | X | X | O | X | X |
| HOLD | X | X | X | O | O |

TABLE 3.2 TRIGGER INPUT SOURCE

Important Notes:

1. X = Non-functional & O = Functional
2. EXT_TRG_IN & ETHERNET triggers input through the respective interface connections
3. *TRG and TRIG:IMM are SCPI commands

PROTECTION

OV PROTECTION

OV DELAY
UV PROTECTION
UV DELAY
OC PROTECTION
OC DELAY

UC PROTECTION

UC DELAY
OP PROTECTION
OP DELAY
UP PROTECTION
UP DELAY

AMREL eLoad provides programmable OVP/OCP/OPP and UVP/UCP/UPP over-limit and under-limit protection capabilities. The user can program all the protection values and delay times. Protection will be activated once the protection mode has been tripped and then shut down the eLoad input. The protection delay setting provides a programmed delay time to accommodate short duration surges without inadvertently shutting the input off.

Protection Sub-Menu Navigation: Press the "Menu/Local" key then turn the \odot encoder to select the PROTECTION function then the "ENTER" key. Turn the \odot encoder to select the appropriate protection or delay function by pressing the "ENTER" key to display the current value. Press the "ENTER" key to edit or enter the new value then press the "ENTER" key to confirm entry. Press the "CLEAR" key to exit from the PROTECTION MODE sub-menu.

V-ON (Under Voltage Lockout): To prevent the eLoad from operating under unstable conditions such as voltages below the minimum operating voltage, the V-On Protection feature can be utilized. The V-On protection will force the input to remain off until the V-On voltage threshold is exceeded, the purpose is to ensure sufficient voltage is delivered to the eLOAD for normal operation. When operating under strict turn-on sequences, such as sending power via a power supply into an eLOAD with the input already turned on, current overshoot, bounce or ringing may occur. As a

recommendation for improved performance without changing the turn-on sequence, the V-On threshold can be increased to a voltage closer to the application's operating voltage and the V-On detection mode changed to "Continuous". By making the necessary adjustments, both the DUT and eLOAD can operate under stable conditions to avoid irregular results. To achieve best results, the V-On Voltage should be set to a level higher than the stabilizing voltage of the power supply or DUT, and higher than the eLOAD's minimum operating voltage. Please refer to "Protection Feature" in section one for a detailed explanation of the different V-On modes.

Fault Signal: Each time a protection fault triggers, the Fault pin becomes active TTL high. When this occurs, the appropriate bits in the status register are set and the fault signal is latched. The status bits will remain set until the electronic load is reset via the GPIB or RS232 (*RST command) or at the front panel (CLEAR key). The condition that caused the protection feature to trip must be corrected or the load will turn off again.

Note: Because the protection is done through software, the response time for the delay trip time must be set to at least 50ms for each protection feature. Otherwise the load may not reset correctly if the trip delay time is too short.

MAX/MIN SETTING FUNCTION

To change the values, press the "Menu/Local" key press Enter, then use the ⏪⏩ keys to select the Max/Min Limit function then the "ENTER" key. Use ⏪⏩ keys to select the appropriate Min/Max setting by pressing the "ENTER" key. The LCD will display the current value, press the "ENTER" key to enter a new value and press the "ENTER" key to confirm entry. Press "CLEAR" key to escape the Max/Min Setting MODE.

The following are special eLOAD MAX/MIN settings that can be programmed to prevent erroneous value entry for specific applications or special power sources that are sensitive to inappropriate operating values.

- MAX VOLTAGE - Max V
- MIN VOLTAGE - 0.000V
- MAX CURRENT - Max A
- MIN CURRENT - 0.0000 A
- MAX RESISTANCE - Max OHM
- MIN RESISTANCE - 0.00 OHM
- MAX POWER - Max W
- MIN POWER - 0.00 W

CALIBRATION PARAMETERS

Please refer to "SECTION 5. CALIBRATION".

OSCILLATE

This function selects between DISABLE/OSC3/OSC2/OSC1/Default System Bandwidth Settings. OSC3 & OSC2 have a slower transient time range and slower bandwidth and OSC1 & Default have a faster transient time range and wider bandwidth.

OSC DETECTION DISABLE AND DELAY FEATURES

For applications that utilize non-pure DC output power to the eLoad input, the OSC detection can be disabled by selecting the "DISABLE" menu choice. The OSC Protection Delay can be increased to 10 seconds for applications that require a buffer to avoid false protection trigger. **Please refer to the menu tree for detailed selection procedures.**



CAUTION

Product used with oscillation protection turned off may cause product failure. Failure occurring as a result of oscillation application or turn-off of this feature will not be covered under warranty.

BOOT INPUT

Boot Input allows the input to be automatically turned on once the unit is powered on. By default, Boot Input is deactivated.

LOAD PROFILE MENU

The profile menu allows 4 different profiles (0~3) to save all current load configurations. As a factory default, profile 0 & 3 are our factory default profile and profile 1 is our syntax profile.

DISPLAY MENU

| | | |
|---------------|-----------------------------------|----------------------------------|
| Display Mode: | V + I (Voltage + Current) | V + C (Voltage + "C" operand) |
| | V + P (Voltage + Power) | V + R (Voltage + Resistance) |
| | I + C (Current + "C" operand) | I + P (Current + Power) |
| | P + C (Power + "C" operand) | I + R (Current + Resistance) |
| | R + P (Resistance + Power) | R + C (Resistance + "C" operand) |
| | V + T (Voltage + Temperature) | I + T (Current + Temperature) |
| | R + T (Resistance + Temperature) | P + T (Power + Temperature) |
| | C + T ("C" operand + Temperature) | |

The LCD display module of the eLoad can be configured to the different measuring combinations.

Press the "Menu/Local" key. Turn the encoder $\cup\cup$ to select the Display, and then press the "ENTER" key and turn the encoder $\cup\cup$ to select the desired function. Press the "ENTER" key to confirm the selection. Press "CLEAR" key to escape the Display Mode.

C OPERAND FOR BATTERY TESTING

"C" Value: 1.0000A

The eLoad provides the "C" operand. This is especially useful for battery testing applications that use "C" as the battery capacity unit. The user can avoid troublesome calculations by monitoring and testing the battery directly. After the user changes the display combination to V + C, all current values entered and/or measured will be in "C" automatically. The Current value will be scaled according to its value in C units, for example if a "C" value of 10 A is entered, a main value setting of 20 A will be represented as 2 C.

Press the "Menu/Local" key, select display mode and then press ENTER. Turn the encoder $\cup\cup$ to select the "C" value. Press the "ENTER" key, input the desired value, and then press "ENTER". Then Press "CLEAR" to exit the "C" operand mode.

SYSTEM FUNCTIONS MENU

To enter a value for a particular function, please follow the correct key sequence indicated under the System Menu above. Press the "Menu/Local" to enter the main menu tree then turn the encoder $\cup\cup$ keys to select the System Menu. Then press the "ENTER" and turn the encoder $\cup\cup$ to further select the next level of commands. Press the Enter key to confirm the selection.

You can press the "Clear" key repeatedly or the "Local" key at any time to exit the function or mode level.

GPIB FUNCTION

The eLoad provides the GPIB/SCPI interface control capability. The following are user configurable GPIB options:

PRIMARY ADDR: 0 → 31

Primary address for GPIB interface has a range from 0 to 31.

Press the "Menu/Local" key then turn the encoder $\cup\cup$ to select the System function, and select GPIB Address then press the "ENTER" key. Turn the encoder $\cup\cup$ to select the PRIMARY ADDR function by pressing enter, turn the encoder

↵ to increase or decrease the GPIB address, then press the “ENTER” key to confirm the value. The number displayed with the “◀” annunciated behind it is the currently selected GPIB address. Press the “CLEAR” to escape the Primary ADDR mode. eLoad needs to be restart in order to synchronize the change.

RS-232 FUNCTION

The eLoad provides an RS-232 interface for remote control. To save setup time for the RS-232 interface configuration, the eLoad has default settings for parity check bit, data length, and stop bit.

Default settings:

| | | |
|---------------------|---|-----------------|
| Data Length: 8 bits | Parity Check bit: No Parity | Stop Bit: 1 bit |
| Handshake: Xon/Xoff | BAUD RATE: 2400/4800//9600/19200/38400/57600/115200 | |

The eLoad only provide seven-baud rate settings for RS-232 communication. Press the "Menu/Local" key and use the encoder ↵ to select the System function (press enter), then use the encoder ↵ to select the RS-232 function then press the "ENTER" key twice to select BAUD RATE function. Use the encoder ↵ to select between 2400 and 115200 then press the "ENTER" key to confirm selection. Press “CLEAR” key to escape the BAUD RATE MODE.

SYNTAX MODE

The Syntax Mode function allows a selection between PEL and PLA/PLW command sets. Please refer to “PEL & PLW/PLA COMMAND COMPATIBILITY APPENDIX” for further information.

EOS CODE

EOS CODE: NULL only
 CR only
 LF only
 CR + LF

In the GPIB communication, the users can define the different End of Interface (EOS) code for each end of the data or command.

Press the "Menu/Local" key then use the encoder ↵ to select the System function then the "ENTER" key. Turn the encoder ↵ to select the EOS function then use the encoder ↵ to scroll and select the desired EOS code method. Press the “ENTER” key to confirm the selection. Press “CLEAR” key to escape the EOS CODE.

BUZZER

Toggles the system sounds on and off.

PANEL LOCK

This function allows the user to lock the front panel with a 6 digit numerical password. The factory default password is: 555555.

ETHERNET FUNCTION

The eLoad provides an Ethernet programming interface. All SCPI commands are also available through Ethernet interface. Obtaining Network Information to connect the eLoad to the network, you only need a network cable with RJ-45 connector. No transceiver is necessary. However, you need to obtain the following information from the eLoad and your network administrator:

1. eLoad Ethernet MAC Address:

It's a twelve digits string that unequally identifies the eLoad unit. It can be obtained from the control board.

2. Network information:

- 1) DHCP server enabled? Yes or no.

- 2) eLoad IP address: ____ . ____ . ____ . ____
- 3) Gateway IP address: ____ . ____ . ____ . ____
- 4) Subnet mask: ____ . ____ . ____ . ____

Setting the eLoad Ethernet Parameters

You need to set the eLoad Ethernet IP address first. The eLoad IP address uniquely identifies the load to other devices on the network, and is required for the eLoad to communicate over the network.

1. Ethernet Network settings: DHCP supported. The purpose of a DHCP (Dynamic Host Configuration Protocol) server is to issue an IP address to a network device that requests an address.
2. The IP address enables the device to communicate with the network. This is similar to personal computer Plug & Play concept.

The following procedure presumes that your eLoad has the Ethernet option and you have connected the eLoad to your network.

If your network supports DHCP server, do the following:

- 1) Power on the eLoad
- 2) Press the LOCAL key on the front panel, and rotate the encoder ⤴ to scroll to the “SYSTEM” menu option.
- 3) Press ENTER to select.
- 4) Choose “ETHERNET” and Press ENTER to select option.
- 5) Select “ADDRESS” and press ENTER to select option.
- 6) Enter the IP address as “0.0.0.0” if it is not and press ENTER.
- 7) Choose “NETMASK” by rotating the encoder ⤴ to scroll and press ENTER to select option.
- 8) Enter the value as “0.0.0.0” if it is not and press ENTER to set value.
- 9) Choose “GATEWAY” by rotating the encoder ⤴ to scroll and press ENTER to select.
- 10) Enter the default gateway IP address as “0.0.0.0” if it is not and press ENTER to set desired address.

To Exit, press LOCAL to go back to the start-up screen

***Note:** Because the DHCP server assigns a dynamic IP address, the value of the eLoad IP address maybe different each time you power on the eLoad. However, if you intend to remotely control the eLoad, a static IP address is more convenient, as the eLoad IP address does not change, making it easier for remote devices to access the eLoad*

If your network does not support DHCP server, you must enter the Ethernet settings manually which you obtained from your network administrator.

***Note:** The following procedure presumes that your eLoad has the Ethernet option and you have connected the eLoad to your network.*

If your network does not support DHCP server, do the following:

- 1) Power on the eLoad

- 2) Press the LOCAL key on the front panel, and rotate the encoder ⤴ to scroll to the “SYSTEM” menu option.
 - 3) Press ENTER to select.
 - 4) Choose “ETHERNET” and Press ENTER to select option.
 - 5) Select “ADDRESS” and press ENTER to select option.
 - 6) Enter the IP address obtained from your network administrator and press ENTER.
 - 7) Choose “NETMASK” by rotating the encoder ⤴ to scroll and press ENTER to select option.
 - 8) Enter the value obtained from your network administrator and press ENTER.
 - 9) Choose “GATEWAY” by rotating the encoder ⤴ to scroll and press ENTER to select.
 - 10) Enter the default gateway IP address obtained from your network administrator and press ENTER
- To Exit, press LOCAL to go back to the start-up screen

The Ethernet Port Number is 3000.

Please contact AMETEK Programmable Power Technical Support for any additional Ethernet Set-up Question.

USB FUNCTION

The eLoad also provides a USB remote interface to connect to your computer. You need to install USB driver included in a CD-ROM shipped with your eLoad.

After your USB driver is installed, the USB port is converted to a virtual COM port. Refer to the “Verify Installed USB Driver using Hyper Terminal (Windows XP/2000/98)” section for detailed procedures on how to verify the USB driver.

Windows XP USB Driver Installation Procedures

Note: You must have administrative privileges to install the USB driver

- 1) Connect eLoad Unit using USB cable
- 2) Click on found new hardware bubble (bottom right hand corner of screen)
- 3) Found New Hardware Wizard installation window will pop up



4) Select the “install from a list or specific location [Advanced]” radio button and click next to continue

5) Select the “Search for the best driver in these locations.” Radio (default) and check only the “search removable media [floppy, CD-ROM...]” checkbox.

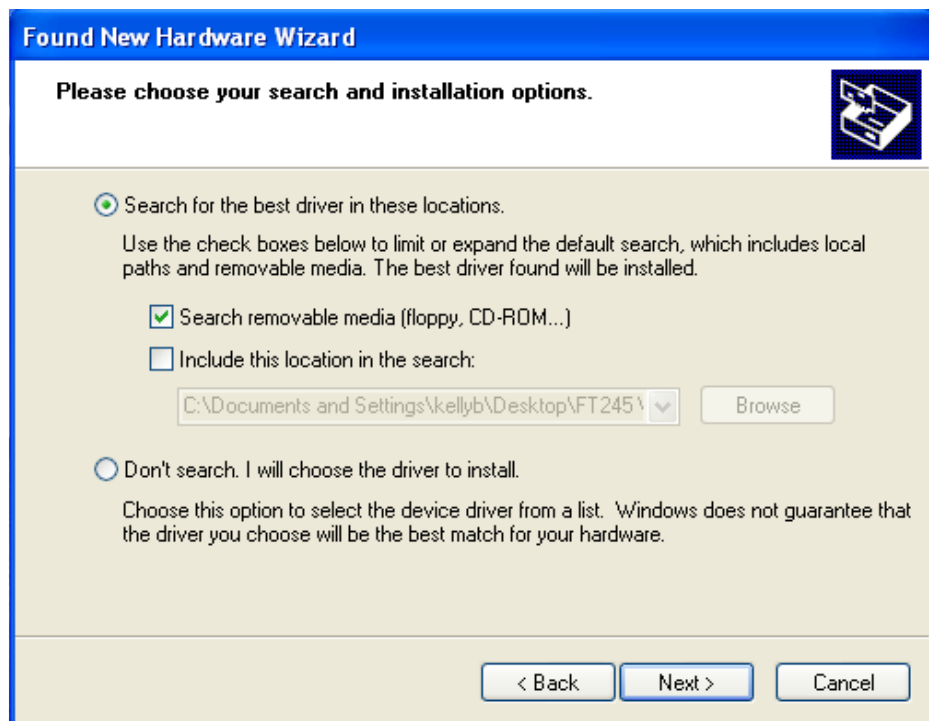

- 6) Click next
- 7) The Wizard will search for the needed drivers

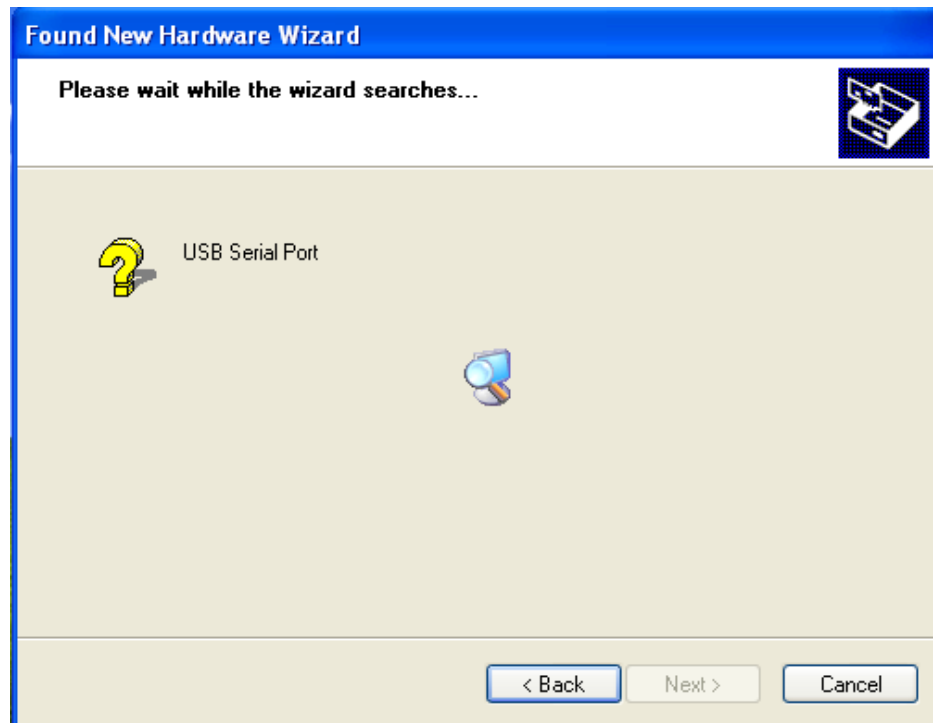

- 8) After the driver has been found, the wizard will display the “completing the Found New Hardware Wizard” screen

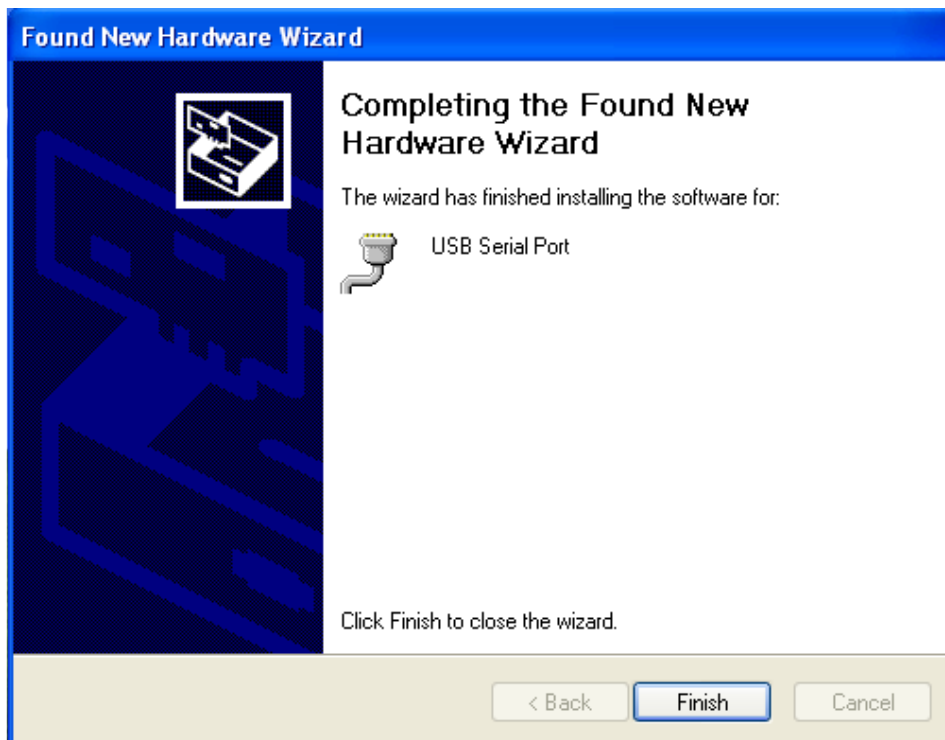

9) Click finish to complete USB driver installation

10) A pop-up balloon will notify you that the USB Serial Device is ready for use

Windows 2000 USB Driver Installation Procedures

1) Connect eLoad using USB cable

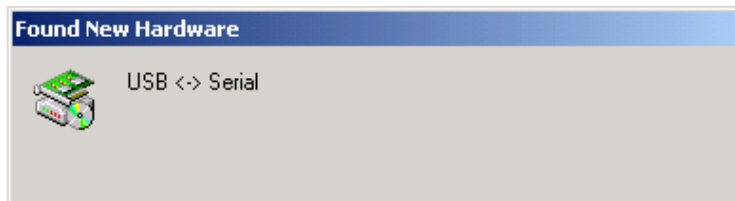

2) A new hardware will be detected



- 3) The “Found New Hardware Wizard” screen will appear
- 4) Click Next to continue



- 5) Select the “Search for suitable driver for my device (recommended)” to search for the appropriate driver
- 6) Click Next to continue

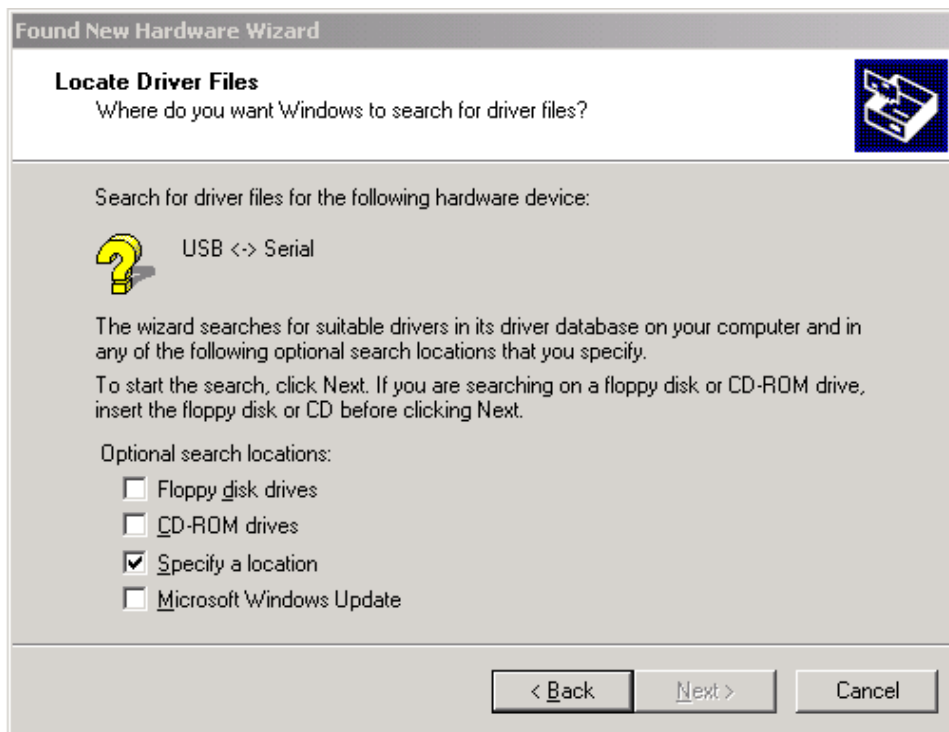

- 7) The driver files are located in the pre-packaged CD
- 8) Check the “Specify a location” check box and click Next to continue

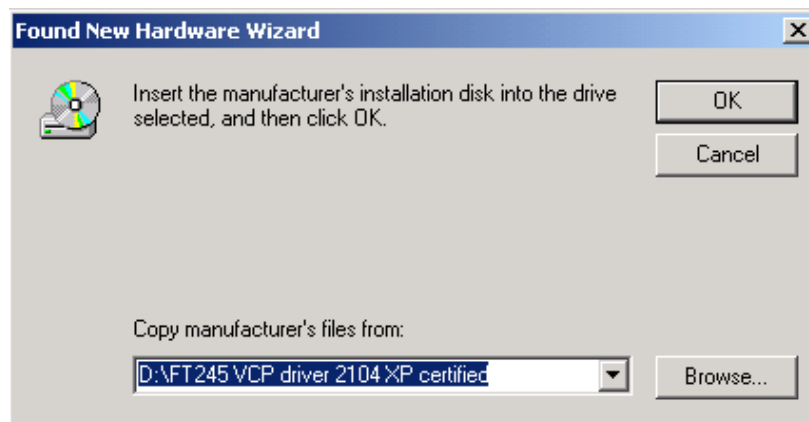

- 9) Select the drive corresponding to your CD-ROM, and locate the folder name “FT245 VCP driver 2104 XP certified”
- 10) Click OK to continue

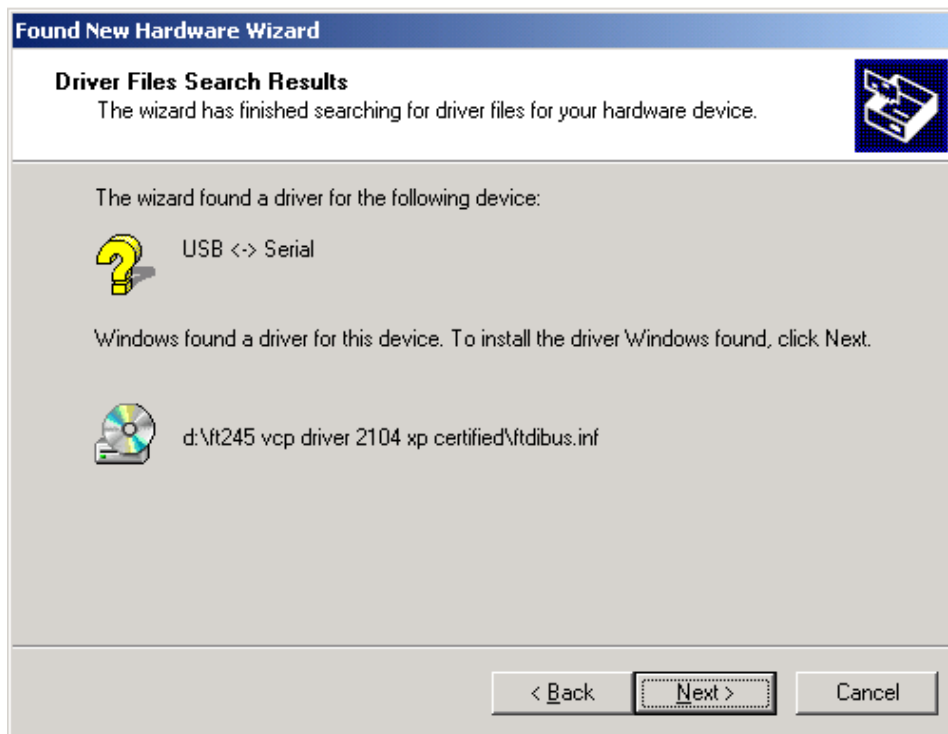

11) The correct driver has been located, click Next to continue installation

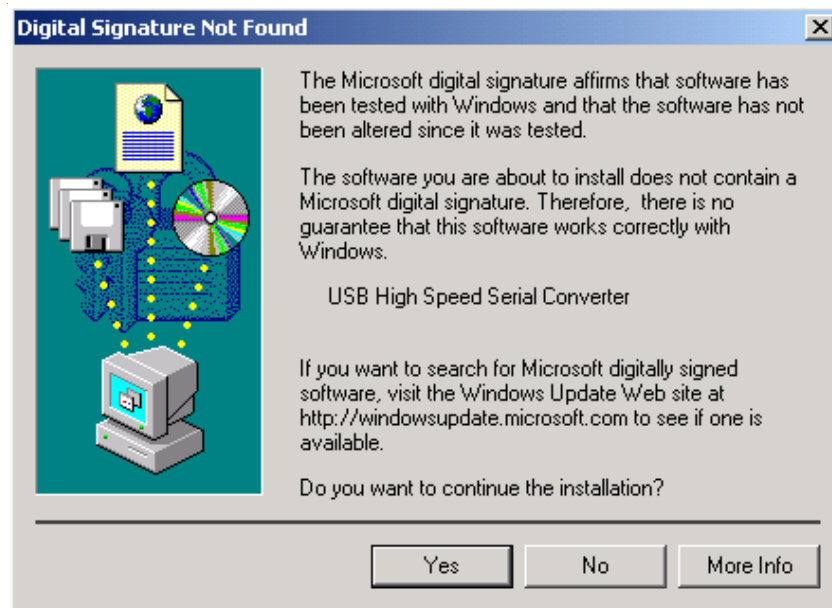

12) Windows will check for the validity of the device driver, click Yes to continue installation

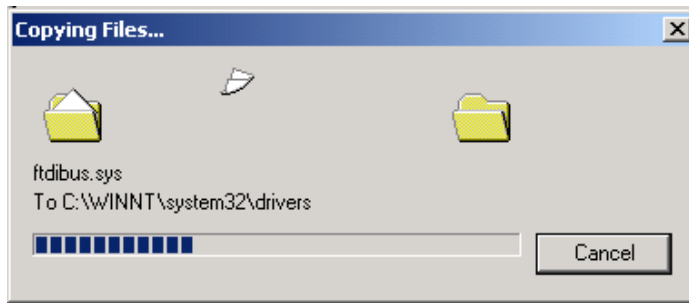

13) Windows will copy the needed drivers to the PC

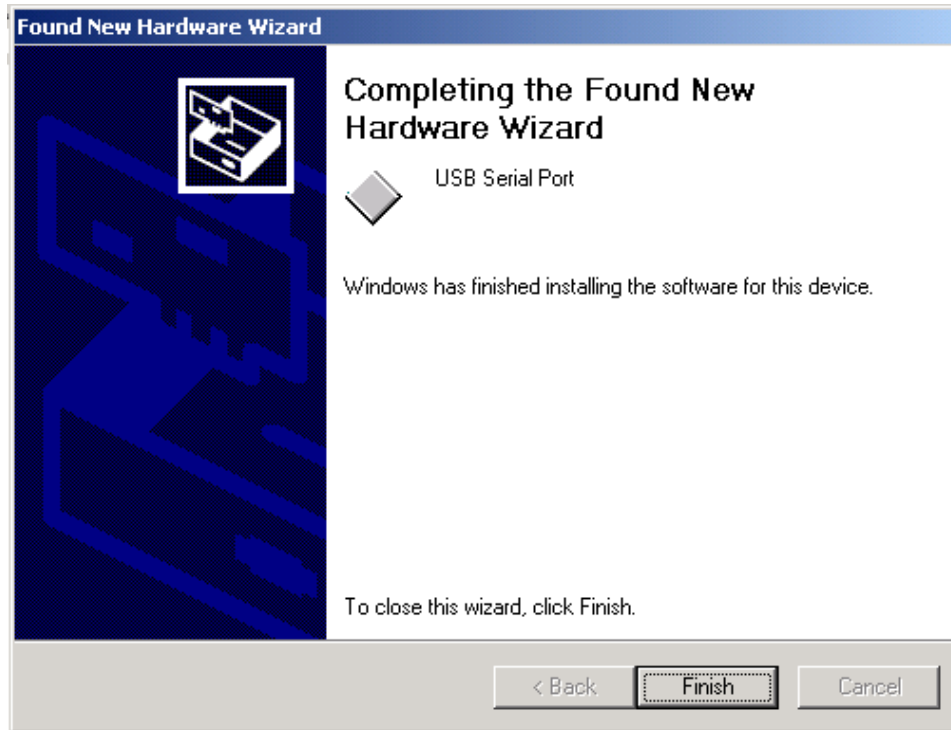

14) The above screen will appear to notify the end of the installation process and the USB Serial Port will now function properly.

15) Click Finish to complete setup

Windows 98 USB Driver Installation Procedures

1) Connect eLoad Unit using USB cable

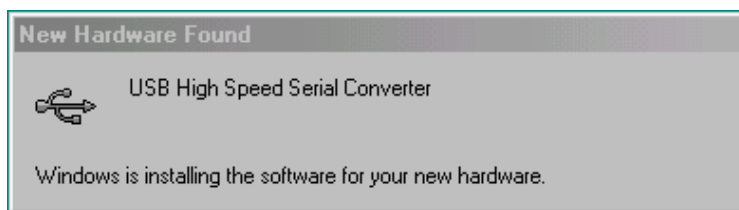

- 2) A new hardware will be detected



- 2) The “Add New Hardware Wizard” window will appear
- 3) Click next to continue



- 4) Select the “Search for the best driver for your device.” radio button, and click Next to continue



- 5) Check the “Specify a location” check box and browse to select the file “FT245 VCP driver 2104 XP certified” from your CD-ROM drive
- 6) Click Next to continue

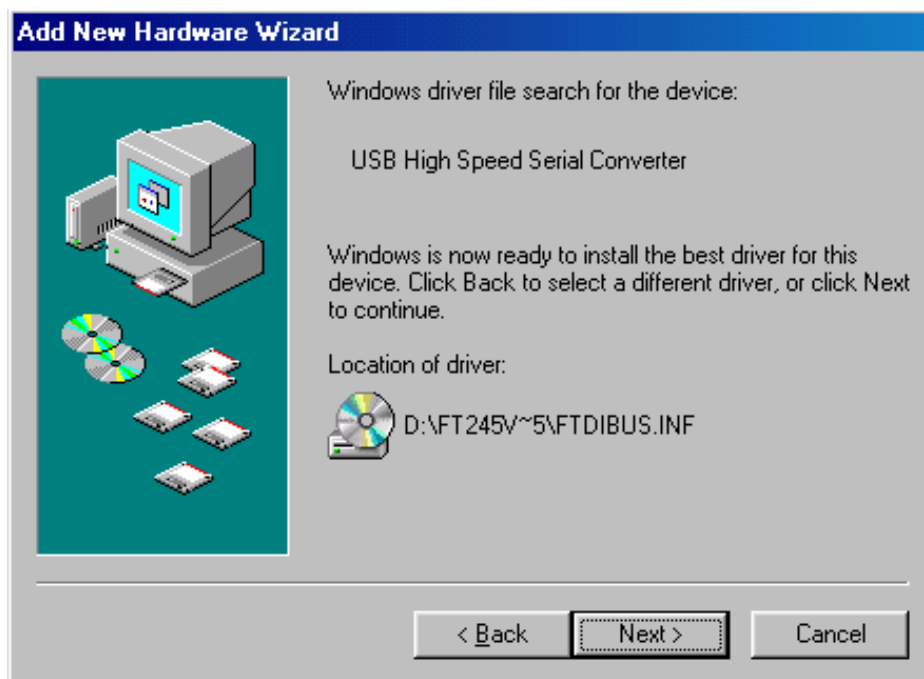

- 7) Now the location of the driver has been set, and click next to install the driver

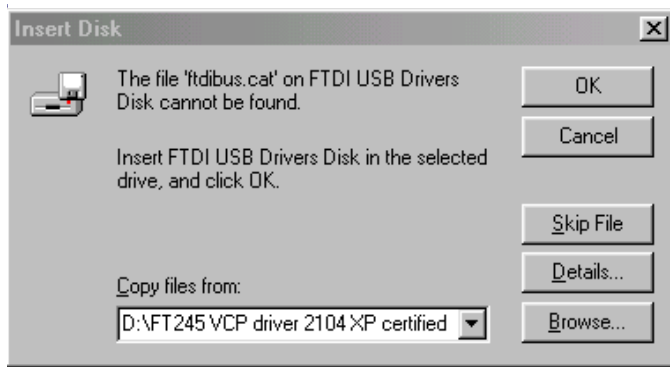

8) Click Cancel and the wizard will automatically locate the needed driver



9) The drivers have been installed successfully, and now the High Speed Serial Converter will work properly

10) Click Finish to complete the installation process

Verify Installed USB Driver using Hyper-Terminal (Windows XP/2000/98)

- 1) Enter into Device Manager window
- 2) Locate and record the “USB Serial Port” COM Port number (under ports)
- 3) Enter into hyper terminal [Start → Accessories → Communications → HyperTerminal]
- 4) Enter connection name, i.e. AMREL
- 5) Choose the corresponding “USB Serial Port” COM Port [To check, right click on My Computer → Properties → Hardware → Device Manager → Ports (note the COM port the High Speed Serial Port is connected to)]
- 6) Choose BPS according to the Baud Rate set on the eLoad unit (the two baud rates have to be the same)
- 7) Click Okay to connect
- 8) Test any SCPI command as desired (i.e. *idn?, addr?)

AUTHENTICATION MENU

SERIAL NUMBER

Displays the serial number/MAC Address of the eLoad unit

INTERFACE

Displays the interfaces activated for the load unit

CODE

Field Upgradeable E-Package (Ethernet +USB) code activation; Please contact factory with serial number/MAC Address to obtain further information.

TRANSIENT OPERATION

The AMREL Programmable Electronic Load can facilitate testing sources and load simulation through the use of its internal transient generator. This transient capability allows the user to determine operating specifications for instruments such as a power supply. This capability also allows for pulse-charging a battery and for simulating battery drain or simulating an electronic switch.

TRANSIENT MODE

Operating in the Transient mode, the eLoad offers 7 operating types: continuous, toggle, pulse, step, step auto, step once and trigger. Each transient mode has a corresponding hot key, with the exception of the different STEP modes which instead is selected from the local menu, and TRIGGER, which is remotely operated. The selected TRANSIENT operation is initiated using the PULSE hot key. After the input is turned on, and the pulse activated, the transient operation will begin upon receiving a trigger signal or continuous mode will activate as soon as transient (pulse) is turned on. If any of the STEP modes is activated via the STEP hot key, then the selected STEP mode will begin once input is on.

All Transient Modes can be selected or activated by using their designated Hot Keys. The Step function has a separate menu for setting the step value, time, and mode selection. The front panel “TRIGGER” hot key will trigger certain transient modes when appropriate.

For **Continuous** mode, once the transient operation is activated the eLoad will switch between main level and transient level based on the duty cycle, frequency and slew time.

For **Pulse** mode operation when amplitude and duration is programmed via GPIB or RS-232 bus. The trigger source comes from GPIB or external TTL trigger.

For **Trigger** mode operation, the eLoad will switch to the set triggered level once a trigger signal is received (trigger signal via GPIB, Ethernet, External port, or Bus). The triggered level can be changed to a value greater or smaller than the main value setting.

For **Toggle** mode operation, the eLoad will toggle once between main level and transient level whenever it receives a trigger signal from GPIB or external TTL trigger.

For **Step/Step Auto/Step Once** operation, the eLoad will switch to the new value setting based on the length and value of the programmed step.

Trigger Out signal can be cascaded via the trigger out port to multiple loads or instrument application where the user requires synchronized triggered events, such as activating different transient values for a group of eLoad. The trigger out signal is a hardwired trigger signal with minimal delay.

ENTERING TRANSIENT MODE VALUES

Example:

The test application requires the main operation to be at 25 A in CC mode and a Transient test current of 50.0 A, Frequency of 500Hz, Slew rate of 5 ms, and a 50% Duty cycle.

1. Set the Transient operation mode to Continuous by pressing the CONT Hot Key.
2. Set CC mode – press the CC hot key.
3. Set main voltage level – press and hold the encoder, the voltage value on the LCD will flash and enter 25.0 A. After you have entered the new current value (25.0) press ENTER to confirm.
4. Set Transient voltage value - press the PEAK hot key to enter transient voltage edit mode and view stored current value. Press and hold the encoder and the transient current value will flash on the LCD, and enter 50.0 A. After you have entered the new current value (50.0) press ENTER to confirm.
5. Set transient Frequency - press the FREQUENCY hot key, tap the encoder to edit or change stored value to 500 Hz then press ENTER to confirm.
6. Set transient Slew rate - press the SLEW hot key and use the encoder "⤵" to scroll to Rise time and tap the encoder to edit or change stored value to 5 ms then press ENTER to confirm.
7. Repeat for Slew Fall Time
8. Set transient Duty Cycle - press the DUTY hot key and tap the encoder to change the duty cycle to 50%, then press ENTER to confirm.
9. Press the CONT hot key to select the Continuous Transient Operation mode.
10. Activate the Continuous Transient operation by pressing the PULSE hot key and the INPUT hot key.

The Transient condition will cycle continuously based on the rise and fall slew time until the CONT transient operation is turned off. By changing the frequency, the transient cycle will increase or decrease in repetition based on the set value.

TRANSIENT FREQUENCY, SLEW RATE AND DUTY CYCLE PROGRAMMING

The transient frequency, slew rate and duty cycle can be programmed directly using the Hot Keys.

1. Press the "FREQ", "SLEW" or "DUTY" hot key to access the transient frequency, slew rate and duty cycle editing mode and LCD module will display the most current setting once the designated hot key is pressed.
2. To change existing values to the appropriate parameter, tap the encoder to activate the edit entry mode.
3. For Frequency editing, the LCD module will display the following:

FREQ = 1000 Hz
4. Enter the following numerical keys "2", "0", "0", "." and "0" keys in sequence in order to change the Frequency to 200Hz.
5. Make sure that the entered number is correct, and press "ENTER" key to complete the entry operation.
6. Press "CLEAR" key to return to the metering mode. By pressing the "Clear" with no entry will display AMREL Model number and software version.

TOGGLE MODE:

In toggle mode, the eLoad input alternates between two user-defined input levels. Unlike transient-continuous mode, the input only changes from one level to another, one transition at a time.

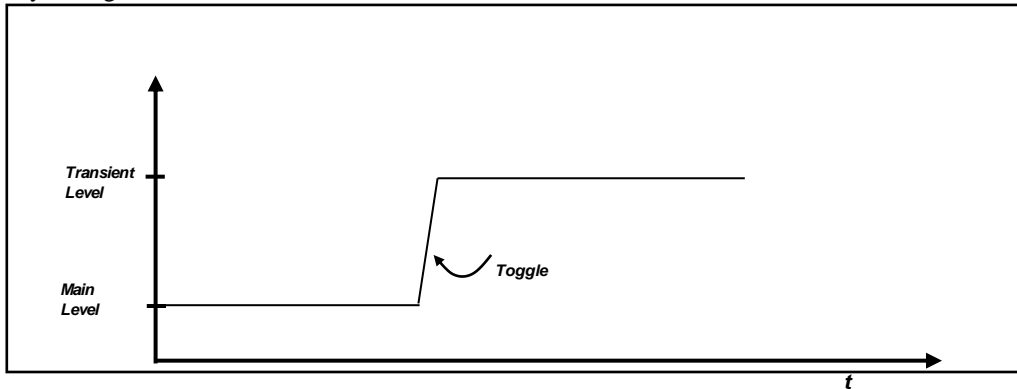

Typical Application: Testing the transient recovery time for a CV power supply. The recovery time for a power supply is defined as the time required for the supply to settle to a predefined settling band following a change in load current caused by an induced transient (pulse).

LCL Operation:

1. Using the mode hot keys, select operating mode (CC, CV, CR, CP)
2. Set the MAIN level by holding down the encoder and rotate to change the value or enter numerically.
3. Set the Transient level by pressing the “PEAK” hot key and edit the value using the encoder or enter manually.
4. Select Continuous transient operation by pressing the “TOGGLE” hot key.
5. Set the duty cycle and frequency by pressing the “DUTY” and “FREQ” hot keys and tapping the encoder to edit each. The duty cycle can be set from 2% to 98% and the frequency from 0.1Hz to 10 KHz. Rotate the encoder clockwise or counterclockwise to change values or enter manually.
6. Set the Rising and Falling Slew Time by pressing “SLEW,” rotate the encoder to select option, tap the encoder to edit slew time value and press “ENTER” to confirm value entry.
7. To begin the continuous transient operation, press the “PULSE” hot key (pulse hot key will blink) and then press the “INPUT” hot key to activate the Toggle transient operation.

PULSE MODE:

In pulse mode, the eLoad generates a pulse with a user-defined amplitude and width. The pulse width can be set from **0.5 ms to 10 seconds**.

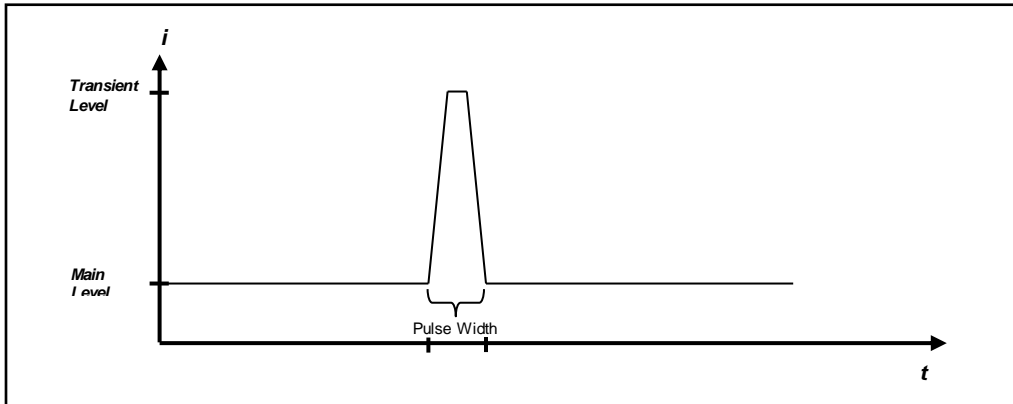

Typical Application: Testing the transient recovery time for a CV power supply. The recovery time for a power supply is defined as the time required for the supply to settle to a predefined settling band following a change in load current caused by an induced transient (pulse).

LCL Operation:

1. Using the mode hot keys, select operating mode (CC, CV, CR, CP)
2. Set the MAIN level by holding down the encoder and rotate to change the value or enter numerically.
3. Set the Transient level by pressing the “PEAK” hot key and edit the value using the encoder or enter manually.
4. Select Continuous transient operation by pressing the “TOGGLE” hot key.
5. Set the duty cycle and frequency by pressing the “DUTY” and “FREQ” hot keys and tapping the encoder to edit each. The duty cycle can be set from 2% to 98% and the frequency from 0.1Hz to 10 KHz. Rotate the encoder clockwise or counterclockwise to change values or enter manually.
6. Set the Rising and Falling Slew Time by pressing “SLEW,” rotate the encoder to select option, tap the encoder to edit slew time value and press “ENTER” to confirm value entry.
7. To begin the continuous transient operation, press the “PULSE” hot key (pulse hot key will blink) and then press the “INPUT” hot key to activate the Toggle transient operation.

Note: Pulse Width is measured from 50% of the rising slope to 50% of the falling slope.

TRIGGER MODE

In trigger mode, the eLoad waits for a trigger signal from the selected trigger source (**HOLD (local), BUS, EXTERNAL and ETHERNET**) to switch to the user configured trigger level. The trigger level can be set to a value greater or less than the main value. After each trigger level is reached, another trigger level can be set and re-triggered to the new trigger level. The trigger operation mode is only available via remote operation. The trigger signal can be sent from any of the trigger sources or via the front panel TRIGGER hot key.

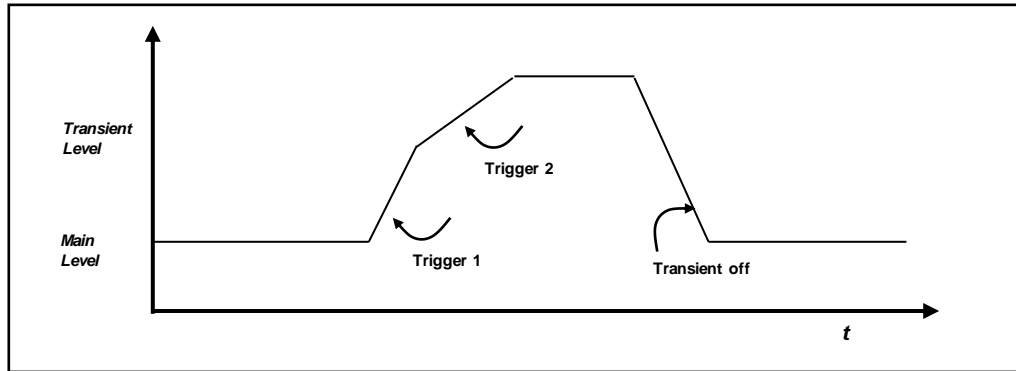

Note: All the operating modes can be programmed via the front panel or using GPIB/RS232/ETHERNET/USB Interfaces with the exception of TRIGGER operation, which is remotely controlled. In addition, each transient mode besides CONTINUOUS can be triggered through a negative edge triggered external TTL compatible signal. CONTINUOUS Transient Operation will start as soon as PULSE is activated, and cannot be activated using a trigger signal.

Setting the Triggered Level:

1. Connect the eLoad to a PC via any of the interfaces (GPIB/USB/Ethernet/RS-232)
2. Communicate with the instrument using e-Tool 1, and confirm connection by sending the command *IDN?
3. The returned parameter should indicate the eLoad's firmware revision number
4. Select the Transient Mode via "TR:MOD 0" command, which will set the eLoad for Trigger operation
5. Select the Trigger Source via TRIG:SOUR and followed by one of the following selections EXT (external trigger), BUS (Bus Trigger), ETH (Ethernet Trigger), and HOLD (Local Trigger). Please refer to the table 3.1 for further trigger source details.
6. Set the Trigger Delay to the desired amount of time via TRIG:DEL and time entry in ms.
7. Set the Triggered Level via CURR:TRIG (current), VOLT:TRIG (voltage), RES:TRIG (resistance) and POW:TRIG (power) command, followed by the desired numerical value, such as 1 or 15.
8. Set the Main Level via CURR, VOLT, RES AND POW command, followed by the desired numerical value.
9. Turn the input on via the INP 1 command.
10. Trigger the eLoad via Trig or *TRG.

Note: The "TRIG" command will trigger under all trigger sources with the exception of Ethernet (Ethernet Trigger is reserved for the MCU-1 Controller), and the *TRG command will only work when the trigger source is selected to "BUS." Please refer to table 3.1 for the appropriate trigger commands for the various trigger sources.

STEP MODE

In step mode, the eLoad generates customized sequence of different input levels up to a maximum of 256 steps (points) for each mode, with dwell times from 1ms to 65535 ms. The step sequence can be cycled for one up to 65535 count(s) or infinity for unlimited repeat. At the end of the step cycle count, turn transient level off and then on to restart the step cycle and count.

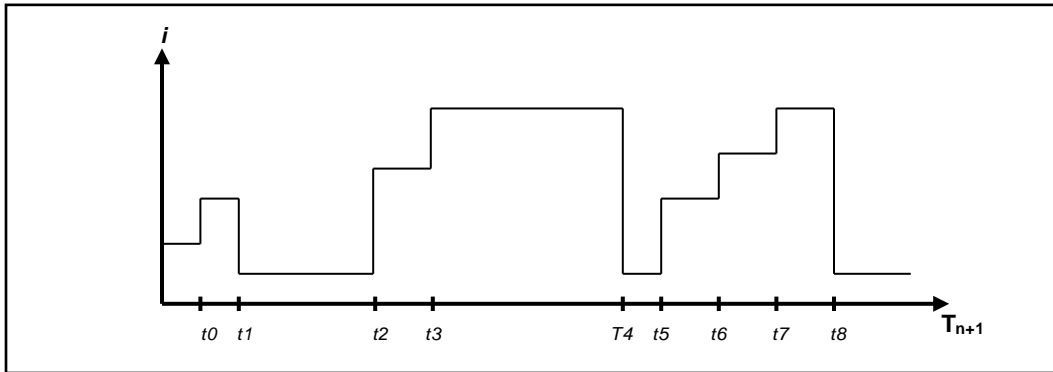

STEP: The Step mode will repeat the step cycle until the end of the dwell time without the need for a trigger signal. Once transient level is activated, the STEP mode will start as well.

STEP AUTO: The Step Auto mode will traverse through the user-defined step cycle until the end of the dwell time upon the receiving a trigger signal.

Note: When triggering the STEP AUTO function via the front panel, when the step is activated (it will show "AUTO"), the step cycle will repeat itself until the end of the Step Parameter setting. If the STEP AUTO function is triggered via PC, the step has to be triggered using a *TRG or TRIG command after the transient level is turned on.

STEP ONCE: The STEP ONCE function will only activate the first step in the step cycle until the next trigger signal is received.

Note: For front panel operation, the STEP ONCE function will only activate the first step in the step cycle. For PC operation, by sending a *TRG or TRIG command with transient on, the next step in the step cycle can be activated.

Typical Application: Simulating battery drain for testing portable, battery powered products. A cellular phone, for example, has complex battery discharge characteristics due to its different operating modes. A load profile can be created using the eLoad load to simulate those characteristics.

STEP OPERATION SET-UP



WARNING

Every time the Stepping mode is enabled, it is critical that you re-enter or double check for the correct amplitude and time of each step programmed. Each step value and time can be check via front panel or remote command, in order to avoid initiating an erroneous step. If the value is set higher than expected the system may perform previous steps that may exceed the power rating for the application and may damage the eLoad or power source.

Important Notes:

- 1) All steps must be in the same constant mode (CV, CC, CR, and CP). Stepping error will occur if different modes are programmed.
- 2) All programmed steps must be saved before power cycling the eLoad, otherwise the data will be lost.
- 3) When eLoad sees a step with a step time 0ms, it will stop executing further step numbers

STEP FUNCTION

The eLoad provides 256 points for self-programming capability for which parameters can be programmed in the Menu function. This feature allows the users to create a mini program and automate the control of the eLoad without the need of computer, GPIB, USB, ETHERNET or RS-232 communication interface. The user is able to set Programming Points, Loop Number, Step Mode and Time Duration (dwell time).

At the Meter Mode, press the STEP key. This will lead eLoad to its step entry menu. Press the STEP menu button to select between time duration (dwell time) and step value for each step number. To change value and time duration for each step press and hold the encoder to select and clear to exit. Turn the encoder to increment/decrement the step number.

After configuring each step, the step sequence will need to be defined. Two parameters will determine the behavior of the overall step cycle. Under MENU → LOAD CONTROL → STEP PARAM. , there are two parameters, (STEP) COUNT and (STEP) MODE.

STEP COUNT

COUNT is the number of loops the step program will be repeated. The stepping function provides loop control with COUNT, which instructs the eLoad to repeat the stepping function, based on the COUNT. For instance, if the COUNT is set to 10 and the eLoad will cycle the desired steps 10 times. If the COUNT is infinity, then eLoad will cycle the stepping infinitely.

To configure the Step Count parameter, Press the "Menu/Local" key press ENTER, then use the encoder ⤴ to select the STEP PARAM. function then the "ENTER" key. Turn the encoder ⤴ to select the Step COUNT then press the "ENTER" key twice to enter the value or use the encoder ⤴ to increment or decrement the value. Press the "ENTER" key to confirm the selection. Press "CLEAR" key to exit from the STEP Configuration Menu.

STEP MODE

MODE provides selection to the different types of step operation: STEP, STEP AUTO, and STEP ONCE.

1. Step will initiate step operation without a trigger signal and repeat until end of the loop number.
2. Step Auto will wait for a *TRG command or TRIG (via PC SCPI command) or front panel trigger to initiate the step operation and will end at the end of the loop number.
3. Step Once will activate one step for every trigger signal received.

To configure the Step MODE parameter, Press the "Menu/Local" key press ENTER, then use the encoder ⤴ to select the STEP PARAM. function then the "ENTER" key. Turn the encoder ⤴ to select the Step MODE then press the "ENTER" key. Different step MODE selections will appear, select the appropriate choice using the encoder ⤴ and press "ENTER" to confirm the selection. Press the "ENTER" key to confirm the selection. Press "CLEAR" key to exit from the STEP Configuration Menu.

ENTERING STEP MODE VALUES

Example:

The test application requires (3) steps to be performed in the Step Mode with the following criteria. Step (1) in the CC mode with 5 amps for 800 ms, step (2) in the CC mode with 10 amps for 400 ms, and step (3) in the CC mode with 50 amps for 200 ms.

Note: CC Mode has 3 ranges. Therefore, if stepping values are in the manual high range, main level value must be set to high range or switch to auto range to cover all current step entries.

1. Choose the STEP transient mode by toggling the Step Parameters selection to Step via the Menu → Load Control → Step Parameters. Press enter to choose the menu selection and turn the encoder ⤴ to select the STEP transient mode and press ENTER key to confirm.

2. Set the STEP Count – Scroll using the encoder ⤴⤵ for the total number of times the steps will be processed via the Menu → Load Control → Step Param. → Count
3. Set first step value - Press the CC hot key, press the STEP key to enter step edit mode, scroll ⤴⤵ to select step 1. Press the STEP key to switch between step value and time settings. Select step value and tap the encoder or press enter. The step current value on the bottom right hand corner of the LCD screen will flash, now enter the new amps value (5.0), and press enter to confirm. Press the STEP key again to scroll to the time edit selection and press enter or tap the encoder to confirm. The step time value on the bottom left hand corner of the LCD screen will flash, now enter the new time value (800), and press enter to confirm.
4. Set second step value - Press the CC hot key, press the STEP key to enter step edit mode, scroll ⤴⤵ to select step 2. Press the STEP key to switch between step value and time settings. Select step value and tap the encoder or press enter. The step current value on the bottom right hand corner of the LCD screen will flash, now enter the new amps value (10.0), and press enter to confirm. Press the STEP key again to scroll to the time edit selection and press enter or tap the encoder to confirm. The step time value on the bottom left hand corner of the LCD screen will flash, now enter the new time value (400), and press enter to confirm.
5. Set third step value - Press the CC hot key, press the STEP key to enter step edit mode, scroll ⤴⤵ to select step 3. Press the STEP key to switch between step value and time settings. Select step value and tap the encoder or press enter. The step current value on the bottom right hand corner of the LCD screen will flash, now enter the new amps value (50.0), and press enter to confirm. Press the STEP key again to scroll to the time edit selection and press enter or tap the encoder to confirm. The step time value on the bottom left hand corner of the LCD screen will flash, now enter the new time value (200), and press enter to confirm.
6. To start the selected STEP mode, press the STEP hot key to initiate the step mode.
7. To enable the STEP mode, press the INPUT hot key.
8. The INPUT will be turned off automatically when the program completes the number of step and loops.

NOTE: *To edit any entry press the STEP menu key and turn the encoder to increment to the desired step. Use the STEP to scroll to select the step value or time setting, and press enter or tap the encoder to select. Use the encoder or numerical keys to change to the desired setting. To program other steps, turn the encoder to increment to the desired step. Press the STEP hot key and turn input on to reactivate STEP mode.*

FOUR: REMOTE OPERATION

INTRODUCTION

The Programming Electronic Load is provided with GPIB and RS-232 Standard Commands for Programmable Instruments (SCPI) interface for automated testing applications. The purpose of this section is to introduce the user to SCPI commands used to control the eLoad via remote communication.

NOTE: For a more comprehensive set of SCPI COMMANDS, please refer to the Programming Manual.

INTRODUCTION TO GPIB & RS-232 (SCPI) COMMANDS

The General Purpose Interface bus is synonymous with HP-IB standard bus used for controlling electronic instruments with a computer. Also called IEEE 488 bus because ANSI/IEEE Standards 488-1978 defines it, 488.1-1987, and 488.2-1987.

Standard Commands for Programmable Instruments (SCPI) is a programming language developed to remotely control different test and measurement instruments over GPIB (IEEE 488) bus. SCPI functions with GPIB hardware conform to the IEEE 488.2 Standard Digital Interface for Programmable Instrumentation. It is a device independent command set and is layered on top of the hardware portion of IEEE 488.2. SCPI simplifies the programming task by defining a single comprehensive command set of programmable instrumentation, regardless of type or manufacturer. The same SCPI command can be applied to different classes of instruments. SCPI systems are much easier to program and maintain. In many cases, you can interchange or upgrade instruments without having to change the test program. SCPI also applies to RS-232 programming.

The electronic load's GPIB address cannot be set via GPIB bus communication or program. The address needs to be set from the front panel keypad in the MENU function.

OVERVIEW SCPI LANGUAGE

The SCPI language uses a hierarchical structure in its programming syntax similar to an inverted tree. The command is organized with root level commands positioned at the top, with multiple sub commands below each root-level command. For example, VOLTage, which is a branch of SOURce, is a command mnemonic and it forms a subtree of its own. VOLTage has three sub-level commands: LEVel, SLEW, TLEVel. At the end of a sub-level command, you can attach a parameter, a question mark (for query), a colon (command mnemonics separator), a semicolon (for multiple commands in a message) or an end of line terminator. To execute a sub-level command, you must specify the complete path from root-level. Each command statement is simply I/O ASCII data strings incorporated within high-level programming language (GW-BASIC, HP BASIC, Quick Basic, Pascal, etc.).

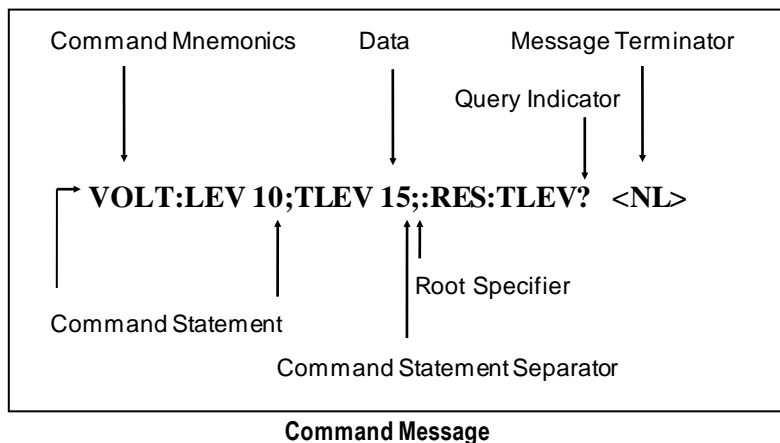

SYNTAX OVERVIEW

Use of the Colon (:)

A colon is used to separate command mnemonics. It indicates a move down in branch level of the command tree. The command follows a colon is a sub command of the command immediate before the colon. When colon precedes the first command mnemonic of a message unit, it becomes root specifier. Its action places the parser (decoder) at the root of the command tree. Parser can only travel downward the command tree. If another command at different branch needs to be executed, a root specifier (colon) is required to place parser at origin and a complete path from root level should also be defined.

Use of the Semicolon (;)

A semicolon is used to separate two command statements with the same command message string. The semicolon does not change location of the parser in the command tree. Only command statements that are in the current path of the first command statement can be combined to form a command message.

Use of the Space ()

A white space is used to separate a parameter (data) from a command mnemonic. When a command statement includes parameter, data always follows the last keyword of a command.

Use of the Comma (,)

A comma is used to separate adjacent parameters if a command requires more than one parameter.

Use of the Query (?)

A query command is used to instruct the instrument to send a response message. Queries return either measured values or internal instrument setting. When a keyword is followed by a question mark, it becomes a query. The ? follows the last keyword of a command statement. You should read back the result of first query before you send out another query or command. Otherwise, returned data will be lost.

Common Commands:

Commands starting with a * and three-letter mnemonic are called common commands. They are generally not related to specific device operation but to perform the identical function for all instruments that are compliant with the IEEE-488.2 interface standard. Common commands can be mixed in with regular Electronic Load commands. The common command will be executed without affecting the position of the parser.

Root-Level Commands:

The root-level commands are those commands specific to the Electronic Load. They are device specific and can be mixed with common commands.

LANGUAGE DICTIONARY

The syntax and parameters for the IEEE 488.2 common commands and SCPI commands used by the Electronic Load is presented in this section. The section starts with description for common commands and then follows by SCPI commands specific to the electronic load.

COMMAND STRUCTURE

The electronic load has two command types for GPIB and RS-232 interface.

Programming commands

Query commands

System commands

Programming commands send programming instructions or values to the electronic load to control the CV/CC/CR/CP functions. There are two types of commands, the SCPI command and instruction commands that co-exist in the program.

SCPI commands should adhere to their syntax and format structure (command line) in order to be properly process by the electronic load.

Query commands request measured values, status, or programmed settings from the electronic load.

System commands belong to the GPIB bus system commands list to controls GPIB bus condition and electronic load interface system. Some commands are not compatible with RS-232 interface.

SCPI (GPIB & RS-232) COMMAND SET

The following describes the GPIB (IEEE488.2) command set for the Programmable Electronic Load Series. All the electronic load commands follow SCPI format and are RS232 compliant. The **commands in brackets are implicit** and don't have to be written out. The letters in bold is the short form syntax of the command mnemonic. For example, the command **CURRent[:LEVel][:IMMEDIATE]** has the following equivalent forms:

```
CURRent:LEVel:IMMEDIATE 5
CURRent:IMMEDIATE 5
CURR:IMM 5
CURR 5
```

All of the above commands will set the Current value to 5Amps.

***NOTE:** The parameters **MIN** and **MAX** designate minimum and maximum programmable value of the range.

Queries for each of the following commands can be obtained by placing a question mark after the command syntax.

Example: CURR?

CURRent ⇒ Current Programming Functions

This subsystem programs the constant current mode functions of the Electronic Load. The IEEE 488.1 command, "ISET" and "SET" (if current active mode is CC mode), can also be used.

CURR

This command sets the input current level that is to be applied immediately in the constant current mode. If the Electronic Load is not in the CC mode when the command is sent, the programmed level is saved and is applied when the Load changes to CC mode. The rate of input change is in accord with the slew rate in effect.

Parameter: 0 to maximum value; MIN; MAX Units: Amp.

Example: "CURR 50" – sets current input level to 50Amps

CURR:PROT:OVER

This command sets a protection limit to the input current that the Electronic Load will sink. When the input current reaches the programmed current limit for the programmed delay period, the Electronic Load input is off and draws no current.

Parameter: 0 to maximum value; MIN; MAX Units: Amp.

Example: "CURR:PROT:OVER 12"- sets the over-current protection to 12 Amps.

CURR:PROT:OVER:DEL

This command sets the delay time in millisecond for current protection. When the input current reaches the programmed current limit for the programmed delay period, the Electronic Load input is off and draws no current.

Parameter: 0 to maximum value; Units: ms.

Example: "CURR:PROT:OVER:DEL 200"- sets the over-current protection delay time to 200 ms.

CURR:PROT:UND

This command sets an undercurrent protection limit to the input current that the Electronic Load will sink. When the input current falls below the undercurrent protection limit for the programmed delay period, the load input is off and draws no current.

Parameter: 0 to maximum value; MIN; MAX Units: Amp.
Example: "CURR:PROT:UND 1.5"- sets the undercurrent protection to 1.5 Amps.

CURR:PROT:UND:DEL

This command sets the delay time for under-current protection. When the input current falls below the undercurrent protection limit for the programmed delay period, the load input is off and draws no current.

Parameter: 0 to maximum value Units: ms
Example: "CURR:PROT:UND:DEL 500"- sets the undercurrent protection delay to 500 ms.

CURR:TRIG

This command sets the input current level that is to be applied on occurrence of a trigger in the constant current mode. If the Electronic Load is not in the CC mode when the command is sent, the programmed TRIG level becomes a stored level that takes effect when the Load changes to CC mode. The rate of input change is in accord with the slew rate in effect.

Parameter: 0 to maximum value; MIN; MAX Units: Amp.
Example: "CURR:TRIG 10" – sets the current trigger level to 10Amps.

CURR:TLEV

This command sets the transient current level in CC mode. When the transient subsystem is on, the Electronic Load will switch between the main level and transient level at a rate determined by the slew rate in effect. If the programmed transient current level is below the main current level, the switching will not occur until the main level is below the value of CURR:TLEV. The IEEE 488.1 command, "ITR" can also be used.

Parameter: Low Range: 0 to maximum value; MIN; MAX Units: Amp.
High Range: 0 to maximum value; MIN; MAX
Example: "CURR:TLEV 30"- sets the current transient level to 30A.

CURR:DUTY

This command sets pulse duty cycle, as a percentage of the total cycle, of continuous transient mode in CC mode. If the Electronic Load is operating in another mode, the duty cycle is stored until the Load changes to continuous mode.

Parameter: 2 to 98; MIN; MAX Unit: %
Example: "CURR:DUTY 50" – sets a 50% duty cycle for transient current mode.

CURR:FREQ

This command sets pulse frequency of continuous transient mode in Hz. If the Electronic Load is operating in another mode, the pulse frequency is stored until the Load changes to continuous mode.

Parameter: 0.25 to 20000; MIN; MAX Unit: Hz
Example: "CURR:FREQ 1000" – sets a 1000Hz frequency for transient current mode.

CURR:SLEW

This command sets the current slew rate for both ranges in CC mode. The programmed slew rate is in effect for all current changes except INP:ON or OFF. The hardware implementation selects a slew rate that is close to the CURR:SLEW value. To determine the actual value, use the query CURR:SLEW?.

Parameter: Low Range: minimum to maximum value; MIN; MAX Units: Amp/ μ s.
High Range: minimum to maximum value; MIN; MAX
Example: "CURR:SLEW 0.1" - sets the current slew rate to 0.1A/ μ s.

CURR:LIM:MAX

This command sets and queries the maximum input current level that is to be applied immediately in the constant current mode.

Parameter: 0 to maximum value; MIN; MAX Units: Amp.
Example: "CURR:LIM:MAX 50" – sets maximum current input level to 50Amps

CURR:LIM:MIN

This command sets and queries the minimum input current level that is to be applied immediately in the constant current mode.

Parameter: 0 to maximum value; MIN; MAX Units: Amp.

Example: "CURR:LIM:MIN 50" – sets minimum current input level to 50Amps

RESistance ⇒ Resistance Programming Functions

This subsystem programs the constant resistance mode functions of the Electronic Load. The IEEE488.1 command, "RSET" and "SET" (if current active mode is CR mode), can also be used.

RES

This command sets the input resistance level that is to be applied immediately in the constant resistance mode. If the Electronic Load is not in the CR mode when the command is sent, the programmed level is saved and is applied when the Load changes to CR mode. The rate of input change is in accord with the slew rate in effect.

Parameter: Low Range: minimum to maximum value; MIN; MAX Units: Ω
Middle Range: minimum to maximum value; MIN; MAX
High Range: minimum to maximum value; MIN; MAX

Example: "RES 5" – sets the resistance level to 5ohms.

RES:TRIG

This command sets the input resistance level that is to be applied on occurrence of a trigger in the constant resistance mode. If the Electronic Load is not in the CR mode when the command is sent, the programmed TRIG level becomes a stored IMM level that takes effect when the Load changes to CR mode. The rate of input change is in accord with the slew rate in effect.

Parameter: minimum to maximum value; MIN; MAX Units: Ω

RES:TLEV

This command sets the transient resistance level in the CR mode. When the transient subsystem is on, the Electronic Load will switch between the main level and transient level at a rate determined by the slew rate in effect. The IEEE 488.1 command, "RTR" can also be used. The input resistance transient switching will occur only when RES:TLEV is programmed as following:

Low Range TLEV>LEV
Middle and high range TLEV<LEV
Parameter: minimum to maximum value; MIN; MAX Units: Ω
Example: "RES:TLEV 15" – sets the resistance transient level to 15ohms.

RES:DUTY

This command sets pulse duty cycle, as a percentage of the total cycle, of continuous transient mode in CR mode. If the Electronic Load is operating in another mode, the duty cycle is stored until the Load changes to continuous mode.

Parameter: 2 to 98; MIN; MAX Unit: %
Example: "RES:DUTY 50" – sets a 50% duty cycle for transient current mode.

RES:FREQ

This command sets pulse frequency of continuous transient mode in Hz. If the Electronic Load is operating in another mode, the pulse frequency is stored until the Load changes to continuous mode.

Parameter: 0.25 to 20000; MIN; MAX Unit: Hz
Example: "RES:FREQ 1000" – sets a 1000Hz frequency for transient current mode.

RES:SLEW

This command sets the current slew rate for both ranges in CR mode. The programmed slew rate is in effect for all current changes except INP:ON or OFF. The hardware implementation selects a slew rate that is closest to the RES:SLEW value. To determine the actual value, use the query RES:SLEW?.

Parameter: Low Range: minimum to maximum value; MIN; MAX Units: Ohm/ μ s.
High Range: minimum to maximum value; MIN; MAX
Example: "RES:SLEW 0.1" - sets the resistance slew rate to 0.1A/ μ s.

RES:LIM:MAX

This command sets and queries the maximum input resistance level that is to be applied immediately in the CR mode.

Parameter: 0 to maximum value; MIN; MAX Units: Ohm.

Example: "RES:LIM:MAX 50" – sets maximum resistance input level to 50 Ohms.

RES:LIM:MIN

This command sets and queries the minimum input resistance level that is to be applied immediately in the CR mode.

Parameter: 0 to maximum value; MIN; MAX Units: Ohm.

Example: "RES:LIM:MIN 50" – sets minimum resistance input level to 50 Ohms.

VOLTage ⇒ Voltage Programming Functions

This subsystem programs the constant voltage mode functions of the Electronic Load. The IEEE488.1 command, "VSET" and "SET" (if current active mode is CV mode), can also be used.

VOLT

This command sets the input voltage level that is to be applied immediately in the constant voltage mode. If the Electronic Load is not in the CV mode when the command is sent, the programmed level is saved to be applied when the Load changes to CV mode. The rate of input change is in accord with the slew rate in effect.

Parameter: 0 to maximum value; MIN; MAX Unit: Volt

Example: "VOLT 120" – sets the voltage level to 120V.

VOLT:PROT:OVER

This command sets a protection limit to the input voltage that the Electronic Load will shunt. When the input current reaches the programmed voltage limit for the programmed delay period, the Electronic Load input is off and shunts no voltage.

Parameter: 0 to maximum value; MIN; MAX Units: Volt.

Example: "VOLT:PROT:OVER 12" – sets the over voltage protection to 12 Volts.

VOLT:PROT:OVER:DEL

This command sets the delay times in millisecond for over-voltage protection. When the input voltage reaches the programmed voltage limit for the programmed delay period, the Electronic Load input is off and shunts no voltage.

Parameter: 0 to maximum value; MIN; MAX Units: ms

Example: "VOLT:PROT:OVER:DEL 1000" – sets the over voltage protection delay to 1000 ms.

VOLT:PROT:UND

This command sets an under voltage protection limit to the input voltage that the Electronic Load will shunt. When the input voltage falls below the under voltage protection limit for the programmed delay period, the load input is off and shunts no voltage.

Parameter: 0 to maximum value; MIN; MAX Units: Volt.

Example: "VOLT:PROT:UND 1.5" – sets the under voltage protection to 1.5Volts.

VOLT:PROT:UNDER:DEL

This command sets the delay times in millisecond for under-voltage protection. When the input voltage falls below the programmed the under voltage protection limit for the programmed delay period, the Electronic Load input is off and shunts no voltage.

Parameter: 0 to maximum value; Units: ms

Example: "VOLT:PROT:UNDER:DEL 1000" – sets the under voltage protection delay to 1000 ms.

VOLT:TRIG

This command sets the input voltage level that is to be applied on occurrence of a trigger in the constant voltage mode. If the Electronic Load is not in the CV mode when the command is sent, the programmed TRIG level becomes a stored IMM level that takes effect when the Load changes to CV mode. The rate of input change is in accord with the slew rate in effect.

Parameter: 0 to maximum value; MIN; MAX Unit: Volt

Example: "VOLT:TRIG 100" – sets the voltage trigger value to 100V.

VOLT:TLEV

This command sets the transient voltage level in CV mode. When the transient subsystem is on, the Electronic Load will switch between the main level and transient level at a rate determined by the slew rate in effect. If the programmed

transient voltage level is below the main voltage level, the switching will not occur until the main level is below the value of VOLT:TLEV. The IEEE488.1 command, "VTR" can also be used.

Parameter: 0 to maximum value; MIN; MAX Unit: Volt
Example: "VOLT: TLEV 50" – sets the voltage trigger level to 50V

VOLT:SLEW

This command sets the voltage slew rate in CV mode. The programmed slew rate is in effect for all voltage changes except INP:ON or OFF. The hardware implementation selects a slew rate that is close to the VOLT:SLEW value. To determine the actual value, use the query VOLT:SLEW?.

Parameter: 0 to maximum value; MIN; MAX Unit: V/μs
Example: "VOLT:SLEW 6"- sets the voltage slew rate to 6V/μs

VOLT:DUTY

This command sets pulse duty cycle, as a percentage of the total cycle, of continuous transient mode in CV mode. If the Electronic Load is operating in another mode, the duty cycle is stored until the Load changes to continuous mode.

Parameter: 2 to 98; MIN; MAX Unit: %
Example: "VOLT:DUTY 50" – sets a 50% duty cycle for transient voltage mode.

VOLT:FREQ

This command sets pulse frequency of continuous transient mode in Hz. If the Electronic Load is operating in another mode, the pulse frequency is stored until the Load changes to continuous mode.

Parameter: 0.25 to 20000; MIN; MAX Unit: Hz
Example: "VOLT:FREQ 1000" – sets a 1000Hz frequency for transient voltage mode.

VOLT:LIM:MAX

This command sets and queries the maximum input voltage level that is to be applied immediately in the constant voltage mode.

Parameter: 0 to maximum value; MIN; MAX Units: Volt.
Example: "VOLT:LIM:MAX 50" – sets maximum voltage input level to 50 Volts

VOLT:LIM:MIN

This command sets and queries the minimum input voltage level that is to be applied immediately in the constant voltage mode.

Parameter: 0 to maximum value; MIN; MAX Units: Volt.
Example: "VOLT:LIM:MIN 50" – sets minimum voltage input level to 50 Volts.

POWER ⇒ Power Programming Functions

This subsystem programs the constant power mode functions of the Electronic Load. The IEEE 488.1 command, "PSET" and "SET" (if current active mode is CP mode), can also be used.

POW

This command sets the input power level that is to be applied immediately in the constant power mode. If the Electronic Load is not in the CP mode when the command is sent, the programmed level is saved and is applied when the Load changes to CP mode. The rate of input change is in accord with the slew rate in effect.

Parameter: 0 to maximum value; MIN; MAX Units: Watt.
Example: "POW 50" – sets current input level to 50Watts.

POW:PROT:OVER

This command sets a protection limit to the input power that the Electronic Load will accept. When the input power reaches the programmed power limit for the programmed delay period, the Electronic Load input is off.

Parameter: 0 to maximum value; MIN; MAX Units: Watt.
Example: "POW:PROT:OVER 12"- sets the overpower protection to 120 Watts.

POW:PROT:OVER:DEL

This command sets the delay time for over-power protection. When the input power reaches the programmed power limit for the programmed delay period, the Electronic Load input is off.

Parameter: 0 to maximum value Units: ms.
Example: "POW:PROT:OVER:DEL 1200"- sets the overpower protection delay time to 1200 ms.

POW:PROT:UND

This command sets an underpower protection limit to the input power that the Electronic Load accepts. When the input power falls below the underpower protection limit for the programmed delay period, the load input is off.

Parameter: 0 to maximum value; MIN; MAX Units: Watt.
Example: "POW:PROT:UND 1.5"- sets the underpower protection to 1.5 Watts.

POW:PROT:UNDER:DEL

This command sets the delay time for under-power protection. When the input power falls below the programmed power limit for the programmed delay period, the Electronic Load input is off.

Parameter: 0 to maximum value Units: ms.
Example: "POW:PROT:UNDER:DEL 1200"- sets the under-power protection delay time to 1200 ms.

POW:TRIG

This command sets the input voltage level that is to be applied on occurrence of a trigger in the constant power mode. If the Electronic Load is not in the CP mode when the command is sent, the programmed TRIG level becomes a stored IMM level that takes effect when the Load changes to CP mode. The rate of input change is in accord with the slew rate in effect.

Parameter: 0 to maximum value; MIN; MAX Unit: Watt.
Example: "POW:TRIG 100" – sets the power trigger value to 100 W.

POW:TLEV

This command sets the transient voltage level in CP mode. When the transient subsystem is on, the Electronic Load will switch between the main level and transient level at a rate determined by the slew rate in effect. If the programmed transient power level is below the main voltage level, the switching will not occur until the main level is below the value of POW:TLEV. The IEEE488.1 command, "PTR" can also be used.

Parameter: 0 to maximum value; MIN; MAX Unit: Watt
Example: "POW: TLEV 50" – sets the power trigger level to 50 W

POW:SLEW

This command sets the power slew rate in CP mode. The programmed slew rate is in effect for all voltage changes except INP:ON or OFF. The hardware implementation selects a slew rate that is closest to the POW:SLEW value. To determine the actual value, use the query POW:SLEW?.

Parameter: 0 to maximum value; MIN; MAX Unit: Watt/ μ s
Example: "POW:SLEW 6"- sets the power slew rate to 6W/ μ s

POW:DUTY

This command sets pulse duty cycle, as a percentage of the total cycle, of continuous transient mode in CP mode. If the Electronic Load is operating in another mode, the duty cycle is stored until the Load changes to continuous mode.

Parameter: 2 to 98; MIN; MAX Unit: %
Example: "POW:DUTY 50" – sets a 50% duty cycle for transient power mode.

POW:FREQ

This command sets pulse frequency of continuous transient mode in Hz. If the Electronic Load is operating in another mode, the pulse frequency is stored until the Load changes to continuous mode.

Parameter: 0.25 to 20000; MIN; MAX Unit: Hz
Example: "POW:FREQ 1000" – sets a 1000Hz frequency for transient power mode.

POW:LIM:MAX

This command sets and queries the maximum input power level that is to be applied immediately in the constant power mode.

Parameter: 0 to maximum value; MIN; MAX Units: Watt.
Example: "POW:LIM:MAX 50" – sets maximum power input level to 50 Watts.

POW:LIM:MIN

This command sets and queries the minimum input power level that is to be applied immediately in the constant power mode.

Parameter: 0 to maximum value; MIN; MAX Units: Watt.
Example: "POW:LIM:MIN 50" – sets minimum power input level to 50 Watts.

INPut/OUTPut ⇒ Input Programming Functions

This subsystem controls the Electronic Load input.

INP[:STATe]

This command turns the Electronic Load input ON and OFF. When the input is off, the Electronic Load draws minimal current at its input. The input turns on or off at the maximum rate, not in accord with the presently programmed slew rate.

Parameter: OFF or 0; ON or 1
Example: "INP 1"- enables the input to the load.

INP:SHOR[:STATe] or SHOR

This command enables/disables electronic short across the Electronic Load input. The actual short condition depends on the active mode and its active operating range. If a mode or range is changed, the short will be reapplied to the new mode or range.

Parameter: OFF or 0; ON or 1
Example: "INP:SHOR 0" – disables the short across the input.

INP:REL

Programming OFF closes the relay contacts; programming ON opens them.

Syntax INP:RELay [STATe]
Parameters 0 | 1; CLOSE | OPEN; OFF | ON

MEASure ⇒ Measurement Query

This subsystem queries and returns the current, voltage, and power at the input of the Electronic Load.

MEAS:CURR[:DC]?

Returns the Electronic Load input current value to the buffer.

MEAS:VOLT[:DC]?

Returns the Electronic Load input voltage value to the buffer.

MEAS:DEL

This command is to sets or queries the delay time to obtain read back value for "MEAS:VOLT?" and "MEAS:CURR?" queries.

Parameter: 0 to 100,000 Units: ms.
Example: "MEAS:DEL 600" – sets the delay time to 600 ms.

MODE / MODE? ⇒ Mode Selection Command/Query

This subsystem selects and queries the operating mode of the Electronic Load

MODE CC or MODE:CURR

This command sets Electronic Load to constant current mode.

MODE CR or MODE:RES

This command sets Electronic Load to constant resistance mode.

MODE CV or MODE:VOLT

This command sets Electronic Load to constant voltage mode.

MODE CP or MODE:POW

This command sets Electronic Load to constant power mode.

MODE:RANGe

This command sets the range after the mode is set.

- Parameters: 0 – 3
- i. low range
 - ii. middle range
 - iii. high range
 - iv. ultra-range

Example: “MODE:RES” – sets the Electronic Load in CR mode;
“MODE:RANG 2” – sets the Electronic Load in high range;
“MODE:RANG? CR” – queries the range for CR mode.

TRANSient ⇒ Transient Programming Function

This subsystem programs the transient functions of three transient modes: **CONT**inuous, **PULSe**, **TOGG**le. The input levels (**TLE**vel) and slew rate (**SLEW**) are programmed from the current, resistance, power and voltage subsystems.

TRAN[:STATe]

This command enables or disables the transient or stepping function. The parameter ON | 1 enables the function and OFF | 0 disables it.

Parameter: ON | 1, OFF | 0
Example: “TRAN ON” – enables the transient function

DUTY

This command sets pulse duty cycle, as a percentage of the total cycle, of continuous transient mode. If the Electronic Load is operating in another mode, the duty cycle is stored until the Load changes to continuous mode.

Parameter: 2 to 98; MIN; MAX Unit: %
Example: “CURR:DUTY 50” – sets a 50% duty cycle for transient current mode.

FREQ

This command sets pulse frequency of continuous transient mode in Hz. If the Electronic Load is operating in another mode, the pulse frequency is stored until the Load changes to continuous mode.

Parameter: 0.25 to 20000; MIN; MAX Unit: Hz
Example: “CURR:FREQ 1000” – sets a 1000Hz frequency for transient current mode.

SLEW

This command sets the power slew rate for the active mode. The programmed slew rate is in effect for all changes except INP:ON or OFF. The hardware implementation selects a slew rate that is closest to the SLEW value. To determine the actual value, use the query SLEW?.

Parameter: 0 to maximum value; MIN; MAX Unit: Depending on mode
Example: “SLEW 6”- sets the slew rate to 6.

TRAN:TWID

This command sets pulse width of pulse transient mode in millisecond. If the Electronic Load is operating in another mode, the pulse width is stored until the Load is powered cycle.

Parameter: 0.05 to 10000 Unit: ms
Example: “TRAN:TWID 800” – sets the pulse width to 800 ms.
Query syntax: “TRAN:TWID?”
Returned parameter: Pulse width value in second.

STEP ⇒ Step Programming Functions

This subsystem programs the stepping functions for stepping mode. The number of loops, step values, and dwell times are programmed for a specified operating mode.

UTIL:STEP:LOOP

This command sets the number of loops the stepping operation will repeat.

Parameter: 0 to 99

Example: "UTIL:STEP:LOOP 10" - sets the number of loops to 10.

If Parameter is set to 0, the loops will repeat indefinitely.

UTIL:STEP:COUNT

This command sets the number of steps activated

Parameter: 1 to 99

Example: UTIL:STEP:COUNT 5" – sets the number of steps to 5.

STEP:MODE <STEP COUNT> <MODE>

This command sets the step number for a specified operating mode.

Parameter for Step count: 0 to 99

Parameter for Mode: 0 (CV); 1 (CC); 2 (CR); 3 (CP)

Example: "STEP:MODE 0 1" – sets to step 0 (first step) in the Constant Current (CC) mode

Note: All steps must be set to same mode and same range.

STEP:VALue <STEP COUNT> <VALUE>

This command sets the step value for a specified step.

Parameter for Step count: 0 to 99

Parameter for Value: 0 to maximum value of operating mode range

Example: "STEP:VAL 0 5" – sets step 0 to 5Amps(CC Mode)

STEP:TIME <STEP COUNT> <TIME>

This command sets the step (dwell) time for a specified step.

Parameter for Step count: 0 to 99

Parameter for Time: 10ms to 600,000ms(10min)

Example: "STEP:TIME 0 1000" – sets time to 1000ms for step 0 (first step)

UTILITY ⇒ Utility Functions

This subsystem sets or queries Menu configurations.

UTIL:MEAS:SENSE

This command sets or queries the measurement sense (Local / Remote).

Parameter: 0 | 1 (0 – Local; 1 – Remote)

Example: UTIL:MEAS:SENS 1 – sets measurement sense to remote sense

UTIL:EOI

This command sets or queries the end of string (EOS) mode for read back.

Parameter: 0 ... 1 (0 – NONE; 1 – CR)

Example: UTIL:EOI 1 – sets the EOS mode to CR

UTIL:TR:MODE

This command sets or queries the transient mode.

Parameter: 0 ... 3 (0 – CONTINUOUS; 1 – STEPPING; 2 – PULSE; 3 – TOGGLE)

Example: UTIL:TR:MODE 0 – sets the transient mode to continuous.

UTIL:CURR <VAL>

This command sets or queries the Electronic Load C value setting.

Example: UTIL:CURR 10.0 – sets C value to 10.0.

UTIL:RANG <VAL>

This command sets or queries the range mode.

Parameters: 0 – Manual range

1 – Auto range

Example: UTIL:RANG 0 – Sets the electronic load to manual range.

SYST:RANG?

This command returns the number of ranges for each mode in a “CV/CC/CR/CP” sequence.

Example: SYST:RANG? – returns “1/2/3/2” means 1 range for CV mode, 2 ranges for CC mode, 3 ranges for CR mode and 2 ranges for CP mode.

COMMON COMMANDS

A common command begins with an * and consists of three letters. It is followed by a “?” if it is a query. They are generally not related to specific device operation but to perform the identical function for all instruments that are compliant with the IEEE488.2 standard. Common commands can be mixed in with regular Electronic Load commands. The eLoad responds to 8 common commands that control internal operation, status and event registers, and system data.

***CLS Clear Status Command**

This command clears the Status Byte summary register and all event register.

***ESR? Event Status Register Query**

This command queries the Standard Event Status register. Reading it clears it.

***IDN? Identification Query**

This query requests the Electronic Load to identify itself. It returns the model number of the unit.

***STB? Status Byte Query**

This query reads the Status Byte Register. Reading the register does not clear it.

***TRG Trigger Command**

This command generates a trigger to the Electronic Load.

***TST? Test Query**

This query causes the Electronic Load to go through a self-test.

***SAV Save Command**

This command stores the present state and calibration data to internal back-up flash memory.

COMMAND LIST

| COMMAND | FORMAT | ACTION |
|----------------------------------|---------------------|------------|
| INPUT enable | INP[?] | 0/1/OFF/ON |
| | INP[:STAT][?] | 0/1/OFF/ON |
| SHORT enable | SHOR | 0/1/OFF/ON |
| | INP:SHOR[:STAT][?] | 0/1/OFF/ON |
| <u>SET commands</u> | | |
| SET value | SET[?] | MAX/MIN |
| SET Voltage | VSET[?] | MAX/MIN |
| | VOLT[:LEV][:IMM][?] | MAX/MIN |
| | VOLT[:LEV]:TRIG[?] | MAX/MIN |
| SET Current | ISET[?] | MAX/MIN |
| | CURR[:LEV][:IMM][?] | MAX/MIN |
| | CURR[:LEV]:TRIG[?] | MAX/MIN |
| SET Resistance | RSET[?] | MAX/MIN |
| | RES[:LEV][:IMM][?] | MAX/MIN |
| | RES[:LEV]:TRIG[?] | MAX/MIN |
| SET Power | PSET[?] | MAX/MIN |
| | POW[:LEV][:IMM][?] | MAX/MIN |
| | POW[:LEV]:TRIG[?] | MAX/MIN |
| <u>TRANSIENT commands</u> | | |
| TRANSient enable | TR[?] | 0/1/OFF/ON |
| TLEV transient level | TLEV[?] | MAX/MIN |
| TRansient Volatge | VTR[?] | MAX/MIN |
| | VOLT:TLEV[?] | MAX/MIN |
| TRansient Current | ITR[?] | MAX/MIN |
| | CURR:TLEV[?] | MAX/MIN |
| TRansient Resistance | RTR[?] | MAX/MIN |
| | RES:TLEV[?] | MAX/MIN |
| TRansient Power | PTR[?] | MAX/MIN |
| | POW:TLEV[?] | MAX/MIN |
| SLEW rate value | SLEW[?] | MAX/MIN |
| SLEW rate Voltage | VOLT:SLEW[?] | MAX/MIN |
| SLEW rate Current | CURR:SLEW[?] | MAX/MIN |
| SLEW rate Resistance | RES:SLEW[?] | MAX/MIN |
| SLEW rate Power | POW:SLEW[?] | MAX/MIN |
| DUTY cycle | DUTY[?] | MAX/MIN |
| DUTY Voltag | VOLT:DUTY[?] | MAX/MIN |
| DUTY Current | CURR:DUTY[?] | MAX/MIN |
| DUTY Resistance | RES:DUTY[?] | MAX/MIN |
| DUTY Power | POW:DUTY[?] | MAX/MIN |
| FREQuency | FREQ[?] | MAX/MIN |
| FREQuency voltage | VOLT:FREQ[?] | MAX/MIN |
| FREQuency current | CURR:FREQ[?] | MAX/MIN |
| FREQuency resistance | RES:FREQ[?] | MAX/MIN |
| FREQuency power | POW:FREQ[?] | MAX/MIN |
| <u>QUERY commands</u> | | |
| MEASure Voltage | MEAS:VOLT[:DC][?] | |
| MEASure Current | MEAS:CURR[:DC][?] | |
| MEASure DELay | MEAS:DEL[?] | |

PROTECTION commands

| | |
|---------------------|-----------------------|
| OVER Voltage value | VOLT:PROT:OVER[?] |
| OVER Current value | CURR:PROT:OVER:[?] |
| OVER Power value | POW:PROT:OVER:[?] |
| UNDER Voltage value | VOLT:PROT:UND[?] |
| UNDER Current value | CURR:PROT:UND[?] |
| UNDER Power value | POW:PROT:UND[?] |
| OVER-V Time Delay | VOLT:PROT:OVER:DEL[?] |
| OVER-C Time delay | CURR:PROT:OVER:DEL[?] |
| OVER-P Time delay | POW:PROT:OVER:DEL[?] |
| UNDER-V Time Delay | VOLT:PROT:UND:DEL[?] |
| UNDER-C Time delay | CURR:PROT:UND:DEL[?] |
| UNDER-P Time delay | POW:PROT:UND:DEL[?] |

LIMIT commands

| | |
|----------------------|-----------------|
| LIMIT Voltage MAX | VOLT:LIM:MAX[?] |
| LIMIT Current MAX | CURR:LIM:MAX[?] |
| LIMIT Resistance MAX | RES:LIM:MAX[?] |
| LIMIT Power MAX | POW:LIM:MAX[?] |
| LIMIT Voltage MIN | VOLT:LIM:MIN[?] |
| LIMIT Current MIN | CURR:LIM:MIN[?] |
| LIMIT Resistance MIN | RES:LIM:MIN[?] |
| LIMIT Power MIN | POW:LIM:MIN[?] |

MODE and RANGE commands

| | |
|--------------|----------------------|
| MODE Query | MODE? |
| CURR MODE | MODE CC |
| | MODE:CURR |
| VOLT MODE | MODE CV |
| | MODE:VOLT |
| RES MODE | MODE CR |
| | MODE:RES |
| POW MODE | MODE CP |
| | MODE:POW |
| MODE RANGE | MODE:RANGe <n> 0...3 |
| | MODE:RANGe? <MODE> |
| SYSTEM RANGE | SYST:RANGe[?] |

STEP commands

| | |
|--------------------|---|
| Utility STEP LOOP | UTIL:STEP:LOOP[?] <VAL> |
| Utility STEP COUNT | UTIL:STEP:COUNT[?] <VAL> |
| STEP MODE | STEP:MODE[?] <STEP COUNT> <MODE> (Must be in same mode and range) |
| STEP VAL | STEP:VAL[?] <STEP COUNT> <VAL> |
| STEP TIME | STEP:TIME[?] <STEP COUNT> <VAL> |

UTILITY commands

| | |
|---------------------------|----------------------------|
| Utility MEASure SENSE | UTIL:MEAS:SENSE |
| Utility End Of Identifier | UTIL:EOI |
| Utility TRansient Mode | UTIL:TR:MODE |
| Utility Current value | UTIL:CURR[?] <VAL> C value |
| Utility Range Operation | UTIL:RANG[?] <VAL> |

FIVE: CALIBRATION

INSTRUCTION



WARNING

Exercise caution when using and calibrating an electronic load. High energy levels can be stored at the input voltage terminals on an electronic load in normal operation. In addition, potentially lethal voltages exist in the power circuit and on the input and sense connectors of a power supply with a rated output greater than 40V. Filter capacitors store potentially dangerous energy for some time after power is removed.



CAUTION

Only qualified personnel should attempt the calibration procedure, due to the high level of power.

This procedure describes calibration for the AMREL Programmable DC Electronic Load. The load is calibrated either through local or remote control. The following information provides calibration procedures in local mode.

NO hardware adjustment is necessary since all calibration is accomplished by software. The software sends calibration constants to the via the front panel keys. To maintain electronic load's precision input, calibration should be performed at least annually.

The nineteen parameters that need to be calibrated. After all the electronic load parameters are calibrated, the load returns to normal operating condition. If there are any errors in the calibration, cycle the power and recalibrate. All constants are saved in a non-volatile EEPROM.

CALIBRATION SERVICE ENVIRONMENT AND PRECAUTIONS

- Follow established antistatic procedures.
- Work at a bench with adequate room and support for the test unit and for all equipment required.
- To reduce shock hazard, use only an insulated, straight-bladed screwdriver when calibrating.

NEVER calibrate these units alone. Ensure that someone is present who can help should an accident occur.

CALIBRATION REQUIRED EQUIPMENT

- DMM
- Current Shunt (Precision Shunt Resistor-0.01ohm, 0.005% accuracy)
- DC power supplies (suitable for CV and CC maximum rating)

NOTE: *Removing any devices or cabling from the overall Calibration Configuration will cause erroneous results, please keep all equipment, device and cabling intact until process is complete.*

CALIBRATION CONFIGURATION

There are two configurations for the calibration of the electronic load. One is for measuring voltage and the other for measuring current.

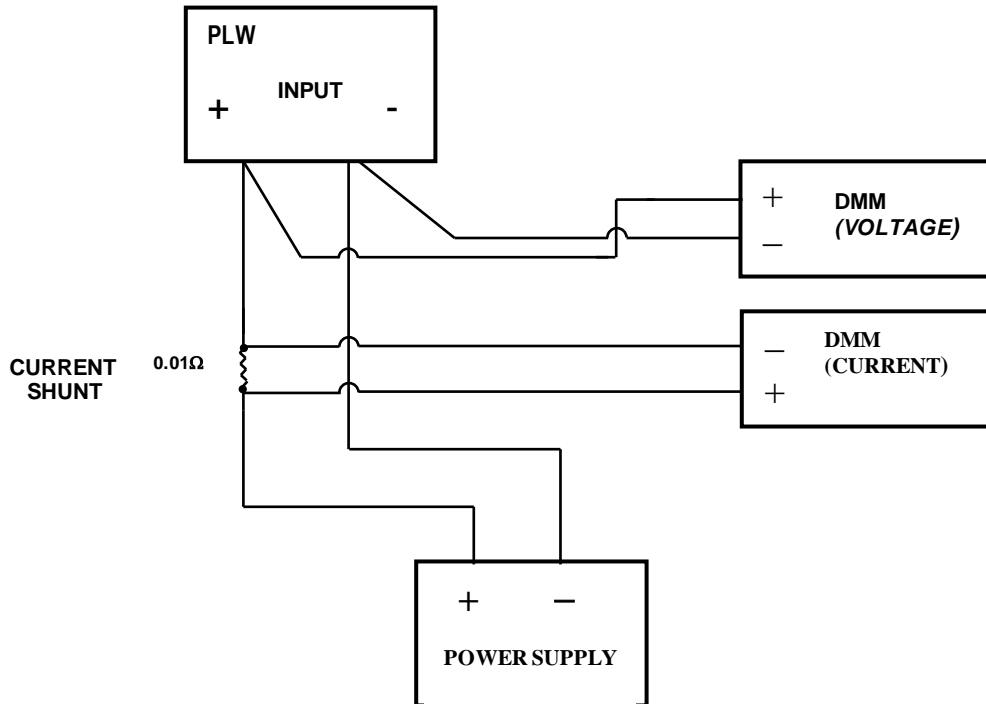

FIGURE 5.1 – CALIBRATION SETUP CONFIGURATION

CALIBRATION PARAMETERS

The following are the parameters that are calibrated.

- CV main level programming.
- CC low range main level programming.
- CC high range main level programming.
- CR low range main level programming.
- CR middle range main level programming.
- CR high range main level programming.
- CP low range main level programming.
- CP high range main level programming.
- CV transient level programming.
- CC low range transient level programming.
- CC high range transient level programming.
- CR low range transient level programming.
- CR middle range transient level programming.
- CR high range transient level programming.
- CP low range transient level programming.
- CP high range transient level programming.
- CV readback.
- CC low range readback.
- CC high range readback.

LOCAL CALIBRATION PROCEDURES

The eLoad uses the two point's calibration method whereby the eLoad has two preset calibration points for each parameter. The microprocessor does the calculation for the operating slope and offset in programming and readback functions. The default calibration points are low point 6400 count and high point 32000 count. These are the default bit counts (DAC circuit) where the 6400 counts point represents approximately 10% of full scale and the 32000 counts point is at 50% full scale. Although these points can be changed in the "Cal. Param." menu, it is not recommended.

The following is the procedure for the calibration of each parameter.

Presses "ENTER" & "." Keys simultaneously to enable the front panel hot keys. The ON/OFF will flash if it's done properly.

Presses "ENTER" & "8" keys simultaneously to enter into calibration mode. Once in calibration mode, the operator can use "⏪" and "⏩" key to shift to the different calibration parameters.

All calibration procedures should be done in the local sensing mode. Voltage local sensing is at the input terminal. In the following calibrations steps, the procedures will suggest certain power supply input, voltage, current and power, but the operator must calculate the power consumption of eLoad to prevent from damaging the unit during calibration.

After calibration is completed, **all new values entered must be saved in the eLoad's flash memory by pressing "3" & ENTER key simultaneously**. It will take approximately 3 seconds for the eLoad to save the new calibration values. During this period, the LCD will display "SAVING CONFIG...". Do not turn-off eLoad during this period.

CONSTANT VOLTAGE (CV) LOW/MIDDLE/HIGH RANGE, MAIN LEVEL CALIBRATION

CV main level calibration requires a power supply that covers the full range of input voltage of the load and is capable of operating in CV and CC mode. Estimate the power consumption of the load, because power supply will go to CC mode while calibrating the load. Adjust the CC current level to a safe limit for load.

Note: Pressing CLEAR key will take you back to previous menu.

Use "⏪" and "⏩" until you see MAIN CV0 parameter. Then press enter:

CV0 LO= CNT: Input measured voltage from Volt.DMM, then press ENTER.
CV0 HI= CNT: Input measured voltage from Volt.DMM then press ENTER key. A "SUCCESS" should be display on the front panel LCD.

Press "⏩" to select MAIN CV1. Then press enter.

CV1 LO= CNT: Input measured voltage from Volt.DMM, then press ENTER
CV1 HI= CNT: Input measured voltage from Volt.DMM then press ENTER key. A "SUCCESS" message should be display on the front panel LCD.

Press "⏩" to select MAIN CV2. Then press enter.

CV2 LO= CNT: Input measured voltage from Volt.DMM, then press ENTER
CV2 HI= CNT: Input measured voltage from Volt.DMM then press ENTER key. A "SUCCESS" message should be display on the front panel LCD.

CONSTANT CURRENT (CC) LOW/MIDDLE/HIGH RANGE, MAIN LEVEL CALIBRATION

CC main level calibration requires a power supply that covers full range high range input current of the load. Estimate the power consumption of the load, and adjust the voltage input to a safe limit for the load.

Use “ \cup ” and “ \cup ” until you see MAIN CC0 parameter. Press enter:

CC0 LO= CNT: Input measured voltage from Curr.DMM, then press ENTER.
CC0 HI= CNT: Input measured voltage from Curr.DMM then press ENTER key. A “SUCCESS” message should be display on the front panel LCD.

Press “ \cup ” to select MAIN CC1. Then press enter.

CC1 LO= CNT: Input measured voltage from Curr.DMM, then press ENTER
CC1 HI= CNT: Input measured voltage from Curr.DMM then press ENTER key. A “SUCCESS” message should be display on the front panel LCD.

Press “ \cup ” to select MAIN CC2. Then press enter.

CC2 LO= CNT: Input measured voltage from Curr.DMM, then press ENTER
CC2 HI= CNT: Input measured voltage from Curr.DMM then press ENTER key. A “SUCCESS” message should be display on the front panel LCD.

CONSTANT RESISTANCE (CR0) LOW RANGE MAIN LEVEL CALIBRATION

CR low range main level calibration requires a power supply that has low voltage and high current, but operator has to estimate the power consumption of load.

Use “ \cup ” and “ \cup ” until you see MAIN CR0 parameter. Press enter:

CR0 LO= CNT: Input measured voltage from Volt.DMM, then press ENTER.
CR0 LO= CNT: Input measured voltage from Curr.DMM, then press ENTER.
CR0 HI= CNT: Input measured voltage from Volt.DMM, then press ENTER.
CR0 HI= CNT: Input measured voltage from Curr.DMM then press ENTER key. A “SUCCESS” message should be display on the front panel LCD.

CONSTANT RESISTANCE (CR1) MIDDLE MAIN LEVEL CALIBRATION

CR middle range main level calibration requires a power supply that has medium voltage and medium current, but operator has to estimate the power consumption of electronic load.

Use “ \cup ” and “ \cup ” until you see MAIN CR1 parameter. Press enter:

CR1 LO= CNT: Input measured voltage from Volt.DMM, then press ENTER.
CR1 LO= CNT: Input measured voltage from Curr.DMM, then press ENTER.
CR1 HI= CNT: Input measured voltage from Volt.DMM, then press ENTER.
CR1 HI= CNT: Input measured voltage from Curr.DMM then press ENTER key. A “SUCCESS” message should be display on the front panel LCD.

CONSTANT RESISTANCE (CR2) HIGH RANGE MAIN LEVEL CALIBRATION

CR high range main level calibration requires a power supply that has high voltage and medium current, but operator has to estimate the power consumption of load.

Use “↵” and “⏎” until you see MAIN CR2 parameter. Press enter:

| | | | |
|-----|-----|------|--|
| CR1 | LO= | CNT: | Input measured voltage from Volt.DMM, then press ENTER. |
| CR1 | LO= | CNT: | Input measured voltage from Curr.DMM, then press ENTER. |
| CR1 | HI= | CNT: | Input measured voltage from Volt.DMM, then press ENTER. |
| CR1 | HI= | CNT: | Input measured voltage from Curr.DMM then press ENTER key. A “SUCCESS” message should be display on the front panel LCD. |

CONSTANT POWER (CP) LOW/MIDDLE/HIGH RANGE, MAIN LEVEL CALIBRATION

CP main level calibration requires a power supply that has enough power output. For example, a PL W6K-60-150 model needs at least 40V/80A power output to calibrate the unit.

Use “↵” and “⏎” until you see MAIN CP0 parameter. Then press enter:

| | | | |
|-----|-----|------|--|
| CP0 | LO= | CNT: | Input measured voltage from Volt.DMM, then press ENTER. |
| CP0 | LO= | CNT: | Input measured voltage from Curr.DMM, then press ENTER. |
| CP0 | HI= | CNT: | Input measured voltage from Volt.DMM, then press ENTER. |
| CP0 | HI= | CNT: | Input measured voltage from Curr.DMM then press ENTER key. A “SUCCESS” message should be display on the front panel LCD. |

Use “↵” and “⏎” until you see MAIN CP1 parameter. Press enter:

| | | | |
|-----|-----|------|--|
| CP1 | LO= | CNT: | Input measured voltage from Volt.DMM, then press ENTER. |
| CP1 | LO= | CNT: | Input measured voltage from Curr.DMM, then press ENTER. |
| CP1 | HI= | CNT: | Input measured voltage from Volt.DMM, then press ENTER. |
| CP1 | HI= | CNT: | Input measured voltage from Curr.DMM then press ENTER key. A “SUCCESS” message should be display on the front panel LCD. |

Use “↵” and “⏎” until you see MAIN CP2 parameter. Press enter:

| | | | |
|-----|-----|------|--|
| CP2 | LO= | CNT: | Input measured voltage from Volt.DMM, then press ENTER. |
| CP2 | LO= | CNT: | Input measured voltage from Curr.DMM, then press ENTER. |
| CP2 | HI= | CNT: | Input measured voltage from Volt.DMM, then press ENTER. |
| CP2 | HI= | CNT: | Input measured voltage from Curr.DMM then press ENTER key. A “SUCCESS” message should be display on the front panel LCD. |

CV TRANCIENT LEVEL CALIBRATION

CV transient level calibration requires a power supply that covers full range of input voltage of load and is capable of operating in CV and CC mode. Estimate the power consumption of eLoad, because power supply will go to CC mode while calibrating the load. Adjust the CC current level to a safe limit for load.

Use “↵” and “⏎” until you see TRAN CV0 parameter. Then press enter:

| | | | |
|-----|-----|------|--|
| CV0 | LO= | CNT: | Input measured voltage from Volt.DMM, then press ENTER. |
| CV0 | HI= | CNT: | Input measured voltage from Volt.DMM then press ENTER key. A “SUCCESS” should be display on the front panel LCD. |

Press “⏎” to select TRAN CV1. Then press enter.

| | | | |
|-----|-----|------|--|
| CV1 | LO= | CNT: | Input measured voltage from Volt.DMM, then press ENTER |
| CV1 | HI= | CNT: | Input measured voltage from Volt.DMM then press ENTER key. A “SUCCESS” message |

should be display on the front panelLCD.

Press “␣” to select TRAN CV2. Then press enter.

CV2 LO= CNT: Input measured voltage from Volt.DMM, then press ENTER
CV2 HI = CNT: Input measured voltage from Volt.DMM then press ENTER key. A “SUCCESS” message should be display on the front panelLCD.

CC LOW/MIDDLE/HIGH RANGE, TRANSIENT LEVEL CALIBRATION

CC transient level calibration requires a power supply that covers full range of high range input current of load. Estimate the power consumption of the electronic load, and adjust the voltage input to a safe limit for the load.

Use “␣” and “␣” until you see TRAN CC0 parameter. Press enter:

CC0 LO= CNT: Input measured voltage from Curr.DMM, then press ENTER.
CC0 HI = CNT: Input measured voltage from Curr.DMM then press ENTER key. A “SUCCESS” message should be display on the front panel LCD.

Press “␣” to select MAIN CC1. Then press enter.

CC1 LO= CNT: Input measured voltage from Curr.DMM, then press ENTER
CC1 HI = CNT: Input measured voltage from Curr.DMM then press ENTER key. A “SUCCESS” message should be display on the front panelLCD.

Press “␣” to select MAIN CC2. Then press enter.

CC2 LO= CNT: Input measured voltage from Curr.DMM, then press ENTER
CC2 HI = CNT: Input measured voltage from Curr.DMM then press ENTER key. A “SUCCESS” message should be display on the front panelLCD.

CR LOW RANGE TRANSIENT LEVEL CALIBRATION

CR low range transient level calibration requires a power supply that has low voltage and high current, but operator has to estimate the power consumption of electronic load.

Use “␣” and “␣” until you see TRAN CR0 parameter. Press enter:

CR0 LO= CNT: Input measured voltage from Volt.DMM, then press ENTER.
CR0 LO= CNT: Input measured voltage from Curr.DMM, then press ENTER.
CR0 HI= CNT: Input measured voltage from Volt.DMM, then press ENTER.
CR0 HI= CNT: Input measured voltage from Curr.DMM then press ENTER key. A “SUCCESS” message should be display on the front panel LCD.

CR MIDDLE RANGE TRANSIENT LEVEL CALIBRATION

CR middle range transient level calibration requires a power supply that has medium voltage and medium current, but operator has to estimate the power consumption of electronic load.

Use “␣” and “␣” until you see TRAN CR1 parameter. Press enter

CR1 LO= CNT: Input measured voltage from Volt.DMM, then press ENTER.

CR1 LO= CNT: Input measured voltage from Curr.DMM, then press ENTER.
CR1 HI= CNT: Input measured voltage from Volt.DMM, then press ENTER.
CR1 HI= CNT: Input measured voltage from Curr.DMM then press ENTER key. A “SUCCESS” message should be display on the front panel LCD.

CR HIGH RANGE TRANSIENT LEVEL CALIBRATION

CR high range transient level calibration requires a power supply that has high voltage and medium current, but operator has to estimate the power consumption of load.

Use “↵” and “⏏” until you see TRAN CR2 parameter. Press enter:

CR2 LO= CNT: Input measured voltage from Volt.DMM, then press ENTER.
CR2 LO= CNT: Input measured voltage from Curr.DMM, then press ENTER.
CR2 HI= CNT: Input measured voltage from Volt.DMM, then press ENTER.
CR2 HI= CNT: Input measured voltage from Curr.DMM then press ENTER key. A “SUCCESS” message should be display on the front panel LCD.

CP RANGE TRANSIENT LEVEL CALIBRATION

CP high range transient level calibration requires a power supply that has enough power output. For example, a PLW6K-60-150 model needs at least 30V/90A power output to calibrate the unit. Only qualified personnel should attempt this calibration, due to the high level of power.

Use “↵” and “⏏” until you see TRAN CP0 parameter. Then press enter:

CP0 LO= CNT: Input measured voltage from Volt.DMM, then press ENTER.
CP0 LO= CNT: Input measured voltage from Curr.DMM, then press ENTER.
CP0 HI= CNT: Input measured voltage from Volt.DMM, then press ENTER.
CP0 HI= CNT: Input measured voltage from Curr.DMM then press ENTER key. A “SUCCESS” message should be display on the front panel LCD.

Use “↵” and “⏏” until you see TRAN CP1 parameter. Press enter:

CP1 LO= CNT: Input measured voltage from Volt.DMM, then press ENTER.
CP1 LO= CNT: Input measured voltage from Curr.DMM, then press ENTER.
CP1 HI= CNT: Input measured voltage from Volt.DMM, then press ENTER.
CP1 HI= CNT: Input measured voltage from Curr.DMM then press ENTER key. A “SUCCESS” message should be display on the front panel LCD.

Use “↵” and “⏏” until you see TRAN CP2 parameter. Press enter:

CP2 LO= CNT: Input measured voltage from Volt.DMM, then press ENTER.
CP2 LO= CNT: Input measured voltage from Curr.DMM, then press ENTER.
CP2 HI= CNT: Input measured voltage from Volt.DMM, then press ENTER.
CP2 HI= CNT: Input measured voltage from Curr.DMM then press ENTER key. A “SUCCESS” message should be display on the front panel LCD.

CV READBACK LEVEL CALIBRATION

CV readback main level calibration requires a power supply that covers full range of input voltage of load and is capable of operating in CV and CC mode. Estimate the power consumption of load, because power supply will go to CC mode while calibrating the load. Adjust the CC current level to safe limit of load.

Use “↵” and “↵” until you see RB CV0 parameter. Then press enter:

CV0 LO= CNT: Input measured voltage from Volt.DMM, then press ENTER.
CV0 HI = CNT: Input measured voltage from Volt.DMM then press ENTER key. A “SUCCESS” message should be display on the front panel LCD.

Press “↵” to select RB CV1. Then press enter.

CV1 LO= CNT: Input measured voltage from Volt.DMM, then press ENTER
CV1 HI = CNT: Input measured voltage from Volt.DMM then press ENTER key. A “SUCCESS” message should be display on the front panel LCD.

Press “↵” to select RB CV2. Then press enter.

CV2 LO= CNT: Input measured voltage from Volt.DMM, then press ENTER
CV2 HI = CNT: Input measured voltage from Volt.DMM then press ENTER key. A “SUCCESS” message should be display on the front panel LCD.

CC LOW RANGE READBACK LEVEL CALIBRATION

CC readback low range calibration requires a power supply that covers full range of high range input current of load. Estimate the power consumption of the electronic load, and adjust the voltage input to a safe limit for the load.

Use “↵” and “↵” until you see RB CRO parameter. Press enter:

CC0 LO= CNT: Input measured voltage from Curr.DMM, then press ENTER.
CC0 HI = CNT: Input measured voltage from Curr.DMM then press ENTER key. A “SUCCESS” message should be display on the front panel LCD.

Press “↵” to select RB CC1. Then press enter.

CC1 LO= CNT: Input measured voltage from Curr.DMM, then press ENTER
CC1 HI = CNT: Input measured voltage from Curr.DMM then press ENTER key. A “SUCCESS” message should be display on the front panel LCD.

Press “↵” to select RB CC2. Then press enter.

CC2 LO= CNT: Input measured voltage from Curr.DMM, then press ENTER
CC2 HI = CNT: Input measured voltage from Curr.DMM then press ENTER key. A “SUCCESS” message should be display on the front panel LCD.

This completes the calibration for all the input parameters for the electronic load.

Press “3” and “ENTER” key simultaneously to save all new calibration parameters into the load’s memory.

RE-INSTALLING CALIBRATION DATA

In case, the calibration data becomes corrupted by abnormal conditions, the Electronic Load has a built in capability for re-installing the last calibration data without having to recalibrate the load.

1. First you need to read the slope and offset values from the electronic load when you receive the unit, or you can call AMETEK Programmable Power Inc to get the calibration information for the electronic load (need serial number)

Get calibration data procedure:

Get slope value:

Run command: “**SYST: SLOPE? <mode>**” to get calibration slope values where “mode” is from 0 to 39. So, there should be 40 values for slope data.

Get offset value:

Run command: “**SYST: OFFS? <mode>**” to get calibration offset values where “mode” is from 0 to 39. So, there should be 40 values for offset data.

2. Once you obtain all the calibration information, you can resave this calibration information to the electronic load.

Resave calibration slope data to electronic load.

Run command: “**SYST: SLOPE <mode> <value>**” where “mode” is from 0 to 39, and the value is the corresponding slope value obtained from 1.

Resave calibration offset data to electronic load.

Run command: “**SYST: OFFS <mode> <value>**” where “mode” is from 0 to 39, and the value is the corresponding offset value obtained from 1.

After re-saving the calibration information for electronic load, you need test the CV and CC mode, and check if the reading back values are within spec.

SIX: NEW ELOAD FEATURES

NEW ELOAD FEATURES

FW: 2.17/060216

- Power Interruption (Current Interruption)

FW: 2.29/061005

- Under-temperature Trip Caution Message (UTT)
- Input Contactor Control
- Ultra-low Range Option

FW: 2.40/061005

- Step Modification
- OSC Range Selection

FW: 2.49/081007

- Interlock Function
- PV Sweep Function

FW: 2.84/100608

- Master-Slave Parallel Operation

FW: 2.90/130129

- Step Time Unit Function.
- New Overpower Function

1. POWER INTERRUPTION (CURRENT INTERRUPTION) MODE:

For Battery and Fuel Cell Testing, a common method used to measure the internal impedance is the Current/Power Interrupt or just the Interrupt method. The battery or fuel cell is loaded at a constant current, and the current is interrupted by bringing it down to zero or lower current level. During the interrupt period, the battery or fuel cell voltage is measured. As a result, the magnitude of the impedance can be determined. The Interrupt method can be achieved in either CC mode or CP mode, with recommendations in the CC mode.

Local Control:

Press SINGLE twice → FLASHING

- Set the eLoad in CC or CP Mode
- Set the Main Level to 0Adc or the desired current level via the encoder
- Set the Peak Level to a current level larger than the Main to load the DUT
Note: Peak Level is set via the PEAK hot key and the encoder for value edit
- Set the Power Interruption Pulse Width (PINT: 200 μs ~ 25000 μs)
- Set the System Bandwidth (OSC3, OSC2, OSC1 and DEFAULT)
- Activate the INPUT
- Activate the PULSE mode
- Press TRIGGER to activate Power Interruption

Remote Programming:

Setting up the Remote Connection:

- 1) Connect the eLoad to the PC via GPIB/RS-232/USB/ETHERNET Cables
- 2) Follow the eTOOL1 Guide to communicate with the eLoad via remote interface
- 3) Once connected, type *IDN? to query the unit

SCPI Commands:

Set the eLoad in CC or CP Mode → *MOD:CURR OR MOD:POW*

Set the Main Level to 0Adc or the desired current level → *ISET or CURR <NRF>*

Set the Peak Level (> Main Level Setting) to load the DUT → *CURR:TLEV <NRF>*

Set the Power Interruption Pulse Width → *TRAN:PINT:TWID 200 μs ~ 25000 μs*

Set the System Bandwidth → (OSC3, OSC2, OSC1 and DEFAULT)

Activate PINT (Power Interruption Mode) → *TRAN:MOD PINT or TRAN:MOD 7*

Activate the INPUT → *INP 1 or INP ON*

Activate the PULSE mode → *TRAN 1 or TRAN ON*

Send TRIGGER signal to activate Power Interruption → **TRG or TRIG*

2. UNDER-TEMPERATURE TRIP WARNING MESSAGE (UTT):

When the heat sink temperature persists at 15 degrees Celsius or below for longer than 10 minutes, a UTT warning message will display on the front panel along with an operational status register bit (bit 11). The warning message indicates the eLoad is operating continuously at low temperatures that may cause condensation; please verify inlet/outlet water pressure differential and temperature are within requirements. Proceed testing with caution to ensure the UTT message does not continue. If message still occurs, please contact AMETEK Technical Support.

Local Control

NONE

Remote Programming

NONE

3. INPUT CONTACTOR CONTROL:

The AMREL eLoad provides a selectable dc Contactor control signal via the INPUT CONTACTOR feature. A TTL active high signal (+5Vdc) or TTL active low signal (0Vdc) will be delivered to the Port_0 (Pin 9) of the 12-pin External Programming Port prior to the eLoad input turning on and after the eLoad turns off, to activate/deactivate an external contactor/relay. To allow time for an external dc contactor to open or close and activate the output of the DUT, the Input Contactor feature offers a programmable delay (50 ~ 500ms) that will delay the eLoad input during load on sequence and the Port_0 signal during load off sequence. The TTL signal is useful for controlling driver circuits for external relays or contactors to isolate an eLoad system from high power DUT during the off-state of the testing application.

| | |
|--------------|---|
| Port 0+ @ On | TTL-High Control Signal at input on; |
| Port 0- @ On | TTL-Low Control Signal at input on; |
| Disable | Disable Input Contactor function; Port_0 function released |
| Delay | Time delay constant before input on and after input off. Parameter: 50~500ms |

Typical eLoad Turn-on Sequence

- 1) Close External Contactor/Relay
- 2) DUT output On (During Delay)
- 3) eLoad input On

Typical eLoad Turn-off Sequence

- 1) eLoad input Off
- 2) DUT Output Off (During Delay)
- 3) Open External Contactor/Relay

Local Control

MENU → LOAD CONTROL → INPUT CONTACTOR → CONTROL → DISABLE
→ PORT0 + @ ON
→ PORT0 - @ ON
→ DELAY → 50ms ~ 500ms

Remote Programming

[SOURce:]INPut:CONtactor

This command configures the INPUT CONTACTOR Mode

| | |
|----------------------------|--|
| Command Syntax | INPut:CONtactor <mode> |
| Parameters | 1: DISABLE 2: PORT0+ @ ON 3: PORT0+ @ ON |
| Query Syntax | INPut:CONtactor? |
| Returned Parameters | 1 2 3 |

[SOURce:]INPut:CONtactor:DELay

This command configures the INPUT CONTACTOR Mode

| | |
|----------------------------|------------------------------------|
| Command Syntax | INPut:CONtactor:DELay <delay-time> |
| Parameters | 50 ~ 500ms |
| Query Syntax | INPut:CONtactor:DELay? |
| Returned Parameters | 50 ~ 500ms |

4. Ultra-low CC & CP and Ultra-high CR Ranges (Optional Feature)

Project requirements are dynamic and over a long time span and often it may need high-current applications one day and ultra-low current applications the next. AMREL eLoad offers an Ultra-low range CC and CP mode and an Ultra-high range CR mode utilizing a unique dual-shunt design which provides precise, accurate, high-resolution and repeatable measurements in thousands of Amps and down to tens of Amps in a single box. The purchase of a single system over the lifetime of the project will yield incredible cost savings in ROI and satisfy dynamic application demands.

Constant Current Ultra Low (CCUL) Range –

- Programming Accuracy: .05% of Setting + .05% of CCUL Max Current
- Read back and Measurement: .05% of Reading + .05% of CCUL Max Current
- Resolution: 14 Bits

Constant Power Ultra Low (CPUL) Range –

- Programming Accuracy: 1% of Setting + .1% of CPUL Max Power
- Read back and Measurement: .05% of Reading + .1% of CPUL Max Power
- Resolution: 14 Bits

Constant Resistance Ultra High (CRUH) Range –

- Programming Accuracy: Please refer to Specifications
- Read back and Measurement: Please refer to Specifications
- Resolution: 14 Bits

Important Notes for CCUL, CPUL and CRUH:

- 1) Cross Mode or Cross Range from one of the normal operating modes into one of the ultra modes will cause the eLoad input to disable and not sink any power
- 2) The maximum current loading in CPUL and CRUH is $(.01 * I_{MAX})$

Local Control:

| <u>MODE</u> | <u>RANGE</u> |
|--|--|
| CONSTANT CURRENT (PRESS CC HOT KEY) | →AUTO →MANU ULO →MANU LOW →MANU MID →MANU HI |
| CONSTANT POWER (PRESS CP HOT KEY) | →AUTO →MANU ULO →MANU LOW →MANU MID →MANU HI |
| CONSTANT RESISTANCE (PRESS CR HOT KEY) | →AUTO →MANU LOW →MANU MID →MANU HI →MANU UHI |

Remote Programming:

[SOURCE:]MODE:RANGe

The command sets and query the operating range at the current operating mode.

| | |
|----------------------------|--|
| Command Syntax | MODE:RANGe <NR1> |
| Parameters | range index 0 – Low Range 1 – Middle Range 2 – High Range 3 – Ultra High/Ultra Low Range |
| Query Syntax | MODE:RANGe? |
| Returned Parameters | <NR1>, range index number |

5. Step Mode Modification

The Step Operation for the eLoad has been modified to provide 256 set points for the step operation. In the older version firmware, the 256 set points are separated into 4 profiles of 256 steps, which limited the amount of total programmable step set points. The latest firmware revision combines all set points into a single profile of 256 steps

STEP MODE

In step mode, the eLoad generates customized sequence of different input levels up to a maximum of 256 steps (points) for each mode, with dwell times from 1ms to 65535 ms. The step sequence can be cycled for one up to 65535 count(s) or infinity for unlimited repeat. At the end of the step cycle count, turn transient level off and then on to restart the step cycle and count.

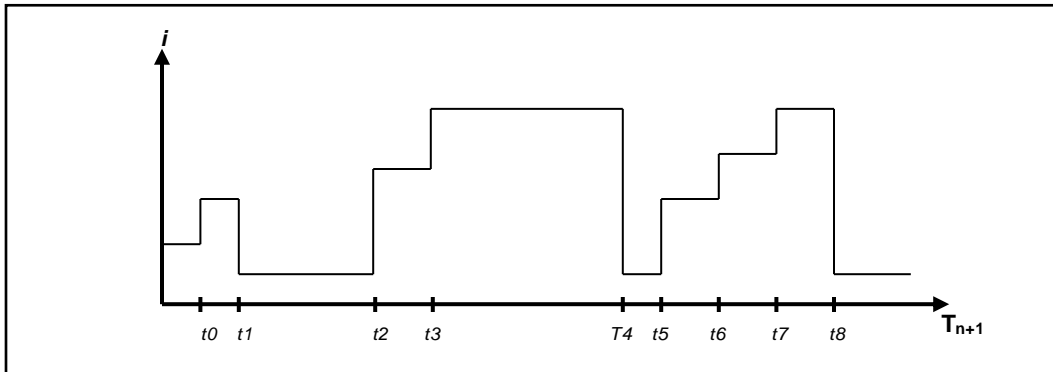

STEP: The Step mode will repeat the step cycle until the end of the dwell time without the need for a trigger signal. Once transient level is activated, the STEP mode will start as well.

STEP AUTO: The Step Auto mode will traverse through the user-defined step cycle until the end of the dwell time upon the receiving a trigger signal.

Note: When triggering the STEP AUTO function via the front panel, when the step is activated (it will show "AUTO"), the step cycle will repeat itself until the end of the Step Parameter setting. If the STEP AUTO function is triggered via PC, the step has to be triggered using a *TRG or TRIG command after the transient level is turned on.

STEP ONCE: The STEP ONCE function will only activate the first step in the step cycle until the next trigger signal is received.

Note: For front panel operation, the STEP ONCE function will only activate the first step in the step cycle. For PC operation, by sending a *TRG or TRIG command with transient on, the next step in the step cycle can be activated.

Typical Application: Simulating battery drain for testing portable, battery powered products. A cellular phone, for example, has complex battery discharge characteristics due to its different operating modes. A load profile can be created using the eLoad load to simulate those characteristics.

Step Remote Operation

STEP ⇒ Step Programming Functions

This subsystem programs the stepping functions for stepping mode. The number of loops, step values, and dwell times are programmed for a specified operating mode.

[SOURCE:]STEP:COUNT

This command sets the number of times that the STEP is executed before it is completed. The command accepts parameters in the range 1 through 65535, or infinity (0). Program "0 (infinity)" as the command parameter will execute a STEP indefinitely.

| | |
|----------------------------|-------------------------------------|
| Command Syntax | STEP:COUNT <NR1> INFinity |
| Parameters | 0 INF(0) 1 TO 65535 MIN MAX |
| Query Syntax | STEP:COUNT? |
| Returned Parameters | <NR1>, Loop Count |

[SOURCE:]STEP:CURRENT[:LEVEL]

This command specifies the current setting for each step.

| | |
|----------------------------|---|
| Command Syntax | STEP:CURRENT <NR1>,<NRf+> |
| Parameters | <NR1> point index, 1 through 256 <NRf+> current level for specified point. Refer to model specifications for range MIN MAX |
| Query Syntax | STEP:CURRENT? <NR1> |
| Parameters | <NR1> point index, 1 through 256 |
| Returned Parameters | <NRf+> current level for specified point |

[SOURCE:]STEP:CURRENT:TIME?

This command specifies the dwell time for each STEP. Each value of point represents the time in milli-seconds that the input will remain at the particular STEP point before completing the step. At the end of the dwell time, the input of the electronic load depends upon the following conditions:

- If STEP:CURRENT:STATE ON has been programmed, the input automatically changes to the next point in the STEP.
- If STEP:CURRENT:STATE AUTO has been programmed, the input waits for a trigger command to change to the next point in the STEP.
- If STEP:CURRENT:STATE ONCE has been programmed, the input remains at the present level until a trigger sequences the next point in the STEP.

| | |
|----------------------------|---|
| Command Syntax | STEP:CURRENT:TIME <NR1>,<NR1> |
| Parameters | 1 st <NR1>, point index 2 nd <NR1>, 0 to 65535 MIN MAX |
| Unit | ms |
| Query Syntax | STEP:CURRENT:TIME? <NR1> |
| Parameters | <NR1> point index |
| Returned Parameters | <NR1> dwelling time value in ms |

[SOURCE:]STEP:CURRENT:STATE

This command specifies how to process the STEP sequencing. The following parameters may be specified.

- **ON** Causes the entire STEP to be executed immediately, paced by its dwell delays. As each dwell delay elapses, the next point is immediately executed.

- **ONCE** Causes the STEP to advance only one point after each trigger. Triggers that arrive during a dwell delay are ignored
- **AUTO** Causes the entire STEP to be executed sequentially after the starting trigger, paced by its dwell delays. As each dwell delay elapses, the next point is immediately executed.

| | |
|----------------------------|--|
| Command Syntax | STEP:CURRent:STATe <NR1> |
| Parameters | 0 OFF(0) 1 ON(1) 2 AUTO(2) 3 ONCE(3) |
| Query Syntax | STEP:CURRent:STATe? |
| Returned Parameters | <NR1> 0=OFF 1=ON 2=AUTO 3=ONCE |

NOTE: Please refer to the eLoad Programming manual and Operation Manual for further Step Operation and comprehensive Step SCPI Commands.

6. OSC Range Selection

The OSC Range selection now includes DISABLE + DEFAULT, DISABLE + OSC1, DISABLE + OSC2 & DISABLE + OSC3. With the new selections, the eLoad provides more bandwidth selections for applications with dc load + ac perturbation. The DISABLE OSC range will stop detection of oscillating conditions; in the case ac + dc inputs are required for testing applications.



CAUTION

Product used with oscillation protection turned off may cause product failure. Failure occurring as a result of oscillation application or turn-off of this feature will not be covered under warranty.

Local Control

MENU

LOAD CONTROL → OSCILLATE → OSC CONTROL

- DEFAULT
- OSC1
- OSC2
- OSC3
- DEFAULT + DISABLE
- OSC1 + DISABLE
- OSC2 + DISABLE
- OSC3 + DISABLE

8. STEPTIME UNIT

This function allows user to select the step time base unit from millisecond to second, which enhanced the maximum dwell time (step time) from 65535ms to 65535s per step point. Up to 256 step points are user programmable. This function will help user to perform long term dynamic loading burn in type of applications or similar.

Local Control

MENU

| | | | |
|--------------|-------------|-------------|----------------------|
| LOAD CONTROL | STEP PARAM. | → MODE | → STEP |
| | | | → STEP AUTO |
| | | | → STEP ONCE |
| | | → COUNT | → 1 ~ INFINITY |
| | | → TIME UNIT | → MILLISECOND |
| | | | → SECOND |

Remote Programming

STEP:TIM[e]:UNIT

This command selects the time base unit for STEP Operation between millisecond or second.

| | |
|-----------------------|-------------------------------|
| Command Syntax | STEP:TIM:UNIT <Action Number> |
| Parameters | <Action Number> |
| | 0: millisecond |
| | 1: second |

| | |
|----------------------------|----------------|
| Query Syntax | TRIG:ACT:PROT? |
| Returned Parameters | 0 1 |
| Default | 0: millisecond |

9. OVERPOWER WARNING MESSAGE (OP):

The eLoad has an Overpower Protection function set at 105% of rated power. If the power based on DC input terminals voltage and current exceeds 105% of rated power, the unit will display a warning message “OP” and the load will limit input current level to maintain the input power to prevent unit from over overload. Over temperature protection may trip if the input power exceeds the rated power persistently.

Local Control

NONE

Remote Programming

NONE

10. PV SWEEP Function

Sweep feature for PV test. Please refer to the descriptions below for details of Sweep operation on eLoad devices. * A graphical PC Software for ELOAD Sweep control is available online for download.

1. SCPI commands

- a. Description: enter/leave sweep operation mode.

Usage: SWE[EP]:ENAB[LE] 0 | OFF | 1 | ON
SWE[EP]:ENAB[LE]?

0, OFF: leave sweep mode.

1, ON : enter sweep mode.

NOTE: 1. while in sweep mode front panel display and key definition will be different from normal Load operation mode.

- b. Description: type of sweep mode.

Usage: SWE[EP]:MOD[E] CURR | CC | VOLT | CV | RES | CR | POW | CP | PV
SWE[EP]:MOD[E] ?

CURR, CC: constant current sweep mode

VOLT, CV : constant voltage sweep mode

RES, CR : constant resistance sweep mode

POW, CP : constant power sweep mode.

PV : Photovoltaic sweep mode.

NOTE: 1. While in PV mode, CV sweep operation will be done, and will also do Isc, Voc test.

2. Isc stand for current measurement while short-circuit.

3. Voc stand for voltage measurement while open-circuit.

- c. Description: dwelling time of each sweep step.

Usage: SWE[EP]:STEP:TIM[E] <step time>
SWE[EP]:STEP:TIM[E]?

<step time>: value between 100 and 60000 in unit of mini-second.

NOTE: (none)

- d. Description: step value increased/decreased of each sweep step.

Usage: SWE[EP]:STEP:VAL[UE] <step value>
SWE[EP]:STEP:VAL[UE]?

<step value>: value between 0 and max. value of mode.

NOTE: 1. step value MUST NOT be 0, or "ERR 3" message will display on front panel while launching sweep operation, and sweep state code will be -3 (while query by SWE:STAT?)

e. Description: the last value for sweep step.

Usage: SWE[EP]:STOP:VAL[UE] <stop value>
SWE[EP]:STOP:VAL[UE]?

<stop value>: value between 0 and max. value of mode.

NOTE: 1. stop value MUST NOT be the same as start value , or "ERR 2" message will display on front panel while launching sweep operation, and sweep state code will be -2 (while query by SWE:STAT?)

f. Description: the first value for sweep step.

Usage: SWE[EP]:STAR[T]:VAL[UE] <start value>
SWE[EP]:STAR[T]:VAL[UE]?

<start value>: value between 0 and max. value of mode.

NOTE: 1. start value MUST NOT be the same as stop value , or "ERR 2" message will display on front panel while launching sweep operation, and sweep state code will be -2 (while query by SWE:STAT?)

g. Description: control or query the sweep state

Usage: SWE[EP]:STAT[E] 0 | OFF | 1 | ON
SWE[EP]:STAT[E]?

0, OFF: force sweep operation to stop
1, ON : launch sweep operation

NOTE: 1. while sweep operation is stopped by "SWE:STAT OFF", "ERR 5" message will display on front panel, and sweep state code will be -5 (while query by SWE:STAT?)

2. meaning of query value:

0 - idle or sweep done

1 - sweep started.

2 - sweep is waiting

3 - sweep is in operation

4 - Isc test is in operation

5 - Voc test is in operation.

-1 - sweep halt, because (start value + step value) > stop value.

-2 - sweep halt, because start value == stop value.

-3 - sweep halt, because step value == 0.

-4 - sweep halt, too many step to operate. (no more than 1000 steps)

-5 - sweep halt by "SWE:STAT 0" or front panel control.

-6 - sweep halt by protected trip.

h. Description: query number of valid data records sampled available.

Usage: SWE[EP]:DATA:COUN[T]?

NOTE: (none)

- i. Description: query data record sampled in sweep operation

Usage: SWE[EP]:DATA:VAL[UE]? <record number>

<record number> - value between 1 and number got by "SWEEP:DATA:COUNT?"
response format: <set value> <measured voltage> <measured current>
<set value> - value set for this step
<measured voltage> - voltage measured in this step
<measured current> - current measured in this step

NOTE: (none)

- j. Description: query current measured while short-circuit.

Usage: SWE[EP]:ISC?

NOTE: 1. This value is ONLY valid in PV sweep mode.

- k. Description: query voltage measured while open-circuit.

Usage: SWE[EP]:VOC?

NOTE: 1. This value is ONLY valid in PV sweep mode.

2. Front panel operation for LPL with VFD display

- a. Sweep disabled mode - eLoad operate in normal mode when "SWEEP:ENABLE OFF".

(refer to manual for details of front panel operation.)

- b. Sweep enabled mode - eLoad operate in sweep mode when "SWEEP:ENABLE ON".

VFD display format - first line of VFD display meter value, while second line of VFD display sweep state like example message below.

"L SWP OFF" - sweep idle state in low range.
"M SWP WAITING" - sweep start waiting in middle range.
"H SWP STEP 5" - sweep operating at 5th step in high range.
"L SWP STEP VOC" - sweep operating at open-circuit in low range.
"L SWP STEP ISC" - sweep operating at short-circuit in low range.
"M SWP STEP ERR 3" - sweep operation halted with error code 3.

Key definition - only INPUT ON/OFF, CLEAR, ENTER, and UTILITY keys are valid.

INPUT ON/OFF - press this key to start/stop sweep operation.
UTILITY - press this key to access menu tree.
CLEAR - press this key to show OEM message, clear protection, or clear sweep error.
ENTER - press this key to show FF, Pm, Voc, Isc, Vmp, Imp value.

Definition of values:

FF: fill factor in %
Pm: max. power value
Voc: measured voltage of open-circuit test
Isc: measured current of short-circuit test
Vmp: measured voltage at max. power step.
Imp: measured current at max. power step.

3. Front panel operation for PLA/PLW new front panel

- a. Sweep disabled mode - eLoad operate in normal mode when "SWEEP:ENABLE OFF".
- b. Sweep enabled mode - eLoad operate in sweep mode when "SWEEP:ENABLE ON".

LCD display format - second line of LCD display sweep state like example message below.

"L SWP OFF" - sweep idle state in low range.
"M SWP WAITING" - sweep start waiting in middle range.
"H SWP STEP 5" - sweep operating at 5th step in high range.
"L SWP STEP VOC" - sweep operating at open-circuit in low range.
"L SWP STEP ISC" - sweep operating at short-circuit in low range.
"M SWP STEP ERR 3" - sweep operation halted with error code 3.

hot key with led definition - only STEP is valid which will launch or stop sweep operation.

utility key definition - only CLEAR, ENTER, and UTILITY keys are valid.

UTILITY - press this key to access menu tree.
CLEAR - press this key to show OEM message, clear protection, or clear sweep error.
ENTER - press this key to show FF, Pm, Voc, Isc, Vmp, Imp value.
Definition of values:
FF: fill factor in %
Pm: max. power value
Voc: measured voltage of open-circuit test
Isc: measured current of short-circuit test
Vmp: measured voltage at max. power step.
Imp: measured current at max. power step.

4. Sweep control menu tree

UTILITY --> SWEEP CONTROL --> ENABLE --> OFF/ON
--> MODE --> PV/CV/CC/CR/CP
--> START VALUE --> start value of sweep step
--> STOP VALUE --> stop value of sweep step
--> STEP VALUE --> step value +- of sweep step
--> STEP TIME --> dwelling time of sweep step

11. Master-Slave Parallel Operation

The eLoad provides Master/Slave configuration at all modes with current sharing capability. Please refer to the steps below for eLoad configuration and control.

Available Mode Ranges

- * CC Mode High Range
- * CP Mode High Range
- * CR Mode Low Range
- * CV Mode Low Range
- * CV Mode Mid-Range
- * CV Mode Hi Range

Setup Configuration

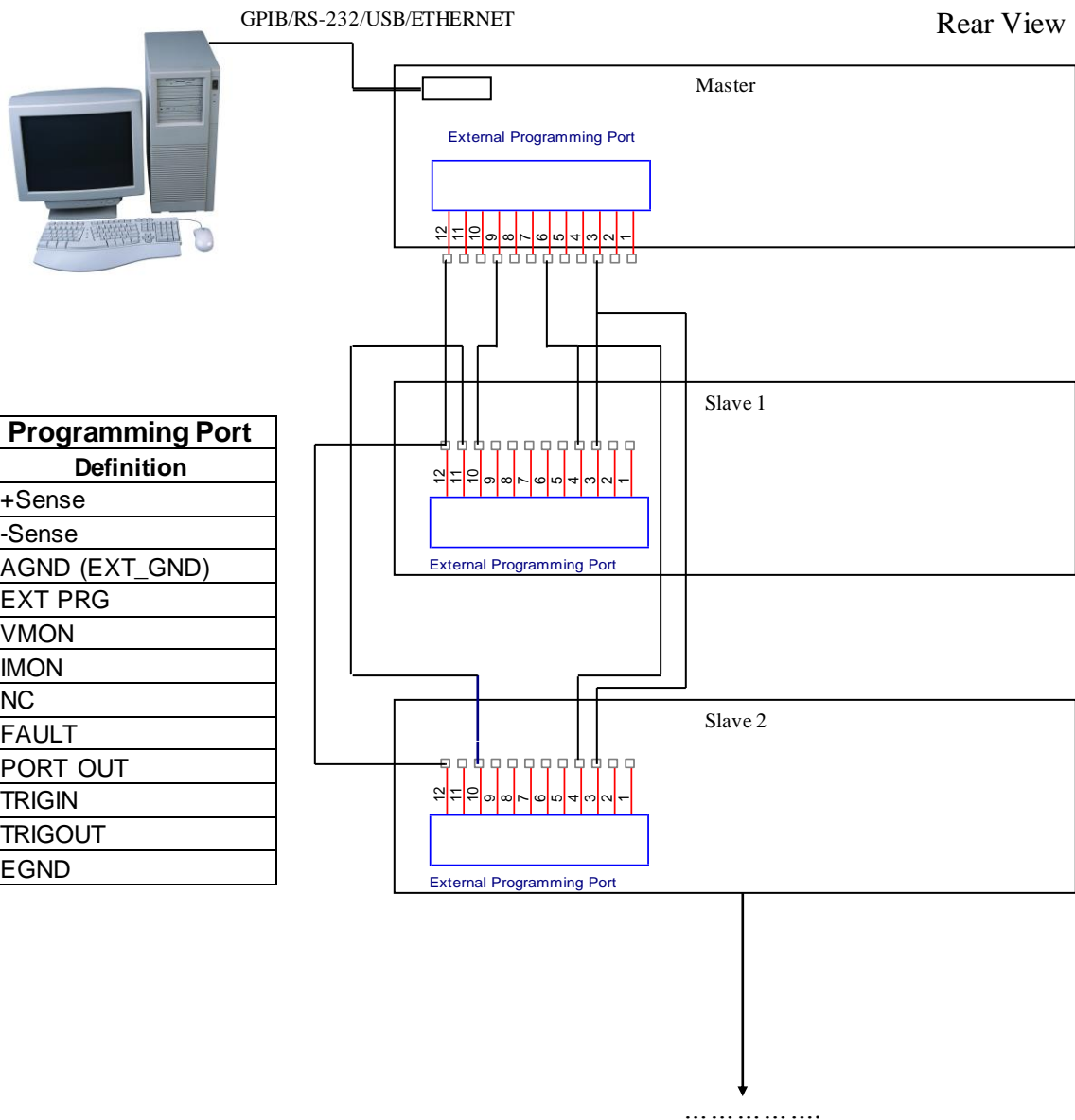

| External Programming Port | |
|---------------------------|----------------|
| Pin | Definition |
| 1 | +Sense |
| 2 | -Sense |
| 3 | AGND (EXT_GND) |
| 4 | EXT PRG |
| 5 | VMON |
| 6 | IMON |
| 7 | NC |
| 8 | FAULT |
| 9 | PORT OUT |
| 10 | TRIGIN |
| 11 | TRIGOUT |
| 12 | EGND |

More devices can be paralleled by daisy chain the Trig_Out of each unit to the Trig_In of the other unit for digital control signal and by connecting the IMON of the Master unit to the EXT_PRG of the Slave units for analog control signal. Be sure the signal return is different between digital signal (EGND) and analog signal (AGND). Connect the RY_NO of each Slave unit to RI of Master unit for System Fault operation.

eLoad Configuration – Master eLoad

1) Mode Control:

Press the **CC/CV/CR/CP** hot keys to activate the operating mode.

2) Manual Range Control: RANGE L,M and H

NOTE: Current Range can be changed to accommodate different current settings – L: 10% of I_{MAX} , M: 50% of I_{MAX} , and H: 100% of I_{MAX} .

3) Set Main Level: Set Main Level to 0 if it is EXT Programming only

4) Set Master+Slave:

- a. Press ENTER and “.” Simultaneously(activate the back door menu)
- b. Press ENTER and LOCAL simultaneously(activate Master/Slave menu)
- c. Select the system configuration by key 4 and key 6 or scrolling flywheel and press ENTER
Master only (Default)
Master + 1 Slave
Master + 2 Slaves
Master + 3 Slaves
Master + 4 Slaves
Master + 5 Slaves

5) Set RI live:

UTILITY → SYSTEM → INHIBIT CONTROL → LATCHED → LIVE

6) Set Trigger Source:

- a. Access the Trigger Source Selection Menu from the Utility Menu
LOCAL (MENU) → LOAD CONTROL → TRIGGER → SOURCE
- b. Press Enter to configure Trigger Source Selection
- c. Select the required trigger source

7) Set Input Contactor Control:

- a. Access the Port_0 TTL output to activate/deactivate the Slave units **LOCAL (MENU) → LOAD CONTROL → INPUT CONTACTOR → CONTROL → PORT0 + @ ON**
- b. Press Enter to have TTL high at Port_0 when Input On
- c. Program the delay 0ms to 500ms if necessary

8) Select System Bandwidth:

MENU → LOAD CONTROL → OSCILLATE → OSC. CONTROL →

OSC3 – Rising and Falling Time = 500 μ s; Slew time of Master should be slower than Slave

- 9) **Saving the Configuration:** Menu → PROFILE → RESET → Enter to update the operating Min/Max ranges (It needs to reset again once changed back to Master only)

eLoad Configuration – Slave eLoad

1) **Manual Range Control:**

RANGE → MANUAL High only

NOTE: It should be high range only in order to have same current setting controlled by IMON from Master unit.

2) **Mode Control:** CC Mode only

3) **EXT.CONTROL:** Set EXT control on

4) **Set Main Level:** Set Current Level to 0Adc

5) **Trigger Source:** Set Trigger Source External

6) **Set Interlock:**

- a. Access the Trigger Source Selection Menu from the Utility Menu
LOCAL (MENU) → LOAD CONTROL → TRIGGER → ACTION EXT → INTLOCK –
- b. Press Enter to configure TTL low at TRIG_IN to disable Input
- c. Press INPUT Hot Key on which will be flashing and waiting for trigger to turn on later.

7) **INPUT always ON**

LOCAL (MENU) → LOAD CONTROL → BOOT INPUT → ON

8) **Select System Bandwidth:**

MENU → LOAD CONTROL → OSCILLATE → OSC. CONTROL

→ OSC1 – Rising and Falling Time = 100 µs; it can be default 50us if necessary

The Slew Hotkey must be press again after changing the slew time setting.

The additional filter board at the input terminal must be added in order to keep the stability at CV mode.

9) **Saving the Configuration:** Menu → PROFILE → SAVE → 0

Note: Location 0 will be stored in the non-volatile memory of the eLoad and will be loaded each time the eLoad is rebooted, however it will be combined with the factory default configuration. Other profile locations 1, 2, & 3 can be used, but will need to be loaded each time the eLoad is rebooted.

System Spec with the same models in parallel

N = Number of Slave + 1,

P = Power rating of Master,

I = Current rating of Master,

R = Resistance rating of Master,

S = Slew time of Master should be less than the slew time of Slave

$P_{system} = P \times N$

$I_{system} = I \times N$

$R_{system} = R/N$

System-min = S x N if Master slew-time = Slave slew-time

Accuracy and Offset = Master Specification x N

Slew Time = Master Specification x N

- 1) With the same models, this configuration can be working as one single unit with increased power and current rating.
- 2) To further improve current accuracy in Master+Slave configuration. User can perform current calibration even in Master+Slave mode.
- 3) It still has all the step, transient or pulse features. Slave slew time must be set to ½ of Master's slew time.
- 4) The CC-Low, CC-Mid, CP-Low, CP-Mid, CR-Mid, CR-High won't be used Master-Slave configuration.
- 5) It could have stability issue at CV mode with very low current level; this also depends upon the wiring and DUT. It would be better adding equivalent RC filter at the input terminal for this case.

REMOTE INHIBIT (RI) & DRY CONTACTS ALARM PIN DEFINITION

In the case of fault conditions, the eLoad provides an externally short-activated emergency shut-off port (Remote Inhibit) that will disengage the eLoad operation. For added protection, normal and deviant conditions can be identified by the Dry Contacts Alarm, which utilizes Normal Open (RY_NO) and Normal Close (RY_NC) relays as alarm indicators for customization of external protection systems. In the case of a protection or AC power loss, the RY_NO will short (closed) and RY_NC will be opened to indicate a fault/deviant condition, either contact can be used to trigger an external alarm.

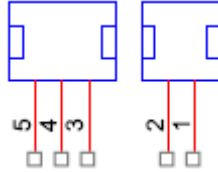

SLAVE PIN 5 GOES TO MASTER PIN 1
SLAVE PIN 4 GOES TO MASTER PIN 2

| Pin Number | Pin Definition |
|-------------------|--|
| 1 – RI+ | Remote Inhibited (RI) is used as an emergency switch to disable the system. RI can be connecting to a switch or an open collector device that shorts the RI pin to common (EGND) whenever it is necessary to disable input of the unit. Once RI is activated, it will turn off the dc output. In order to re-activate the unit, the connection between common and RI pin needs to be open again, and it will have 3 seconds delay. |
| 2 – RI- | The EGND return path for RI+ pin. Shorting RI+ and RI- (Pin 1 & Pin 2) will trigger RI protection. |
| 3 – RY_NC | Dry Contacts alarm: a fault alarm is declared if there is a loss of AC power or protections are triggered. The fault alarm outputs provide a normally closed relay configuration that provides user's flexibility and isolation required to an external controller or an external alarm panel. The delay is 3 second |
| 4 – RY_CO | Relay Common. Provides the common (reference) connection only for RY_NC or RY_NO |
| 5 – RY_NO | Dry Contacts alarm: a fault alarm is declared if there is a loss of AC power or protections are triggered. The fault alarm outputs provide a normally open relay configuration that provides user's flexibility and isolation required to an external controller or an external alarm panel. The delay is 3 second. |

SEVEN: SPECIFICATION AND POWER CURVE

COMMON SPECIFICATIONS

| Constant Voltage Mode | |
|---|--|
| CVHigh Range | (0-V) V |
| CVMedium Range | 0 - (V / 2) V |
| CVLow Range | 0 - (/ 10) V |
| Temp Coefficient | 100 ppm / °C of Rated Voltage |
| Transient Time Range | |
| Fast Band(default, Osc1) | 0.500 ~ 51.19 ms |
| Slow Band(Osc2, Osc3) | 0.500 ~ 511.9 ms |
| CV Resolutions*2 | 1/16000 of rated voltage |
| CV Accuracy*2 (CVH, CVM, CVL) | 0.05% +/- (0.1% x Vmax) V |
| Display Specifications | |
| CV Resolution | 1/16000 of Rated Voltage |
| CV Accuracy (CVH, CVM, CCL) | 0.05% +/- (0.1% x V) V |
| Constant Power Mode | |
| CPHigh Range | (0-P) W |
| CPMedium Range | 0 - (P/2) W @ DC input current ≤ (I/2) A |
| CPLow Range | 0 - (P/10) W @ DC input current ≤ (I/10) A |
| Transient Time Range | Same as CC Mode |
| Temperature Coefficient | 300 ppm / °C of Rated Power |
| Constant Power Mode : Program | |
| CPHigh Accuracy*2 | 1.00% +/- (Px0.5%) W @ input current > (I/20) A, input voltage > (V/10) V |
| CPMedium Range | 1.00% +/- (Px0.5%) W @ input current > (I/100) A, input voltage > (V/10) V |
| CPLow Range | 1.00% +/- (Px0.5%) W @ input current > (I/1000) A, input voltage > (V/5) V |
| Program | CP Resolution*2 1/16000 of Rated Power |
| Constant Current Mode | |
| CCHigh Range | 0 - 1 A |
| CCMedium Range | 0 - (I/2) A |
| CCLow Range | 0 - (I/10) A |
| Transient Time Range | |
| Fast Band (default, Osc1) | 0.050 ~ 51.19 ms |
| Slow Band (Osc2, Osc3) | 0.500 ~ 511.9 ms |
| Temperature Coefficient | 100 ppm / °C of Rated Current |
| Constant Current Mode : Program | |
| CC Resolution*2 | 1/16000 of rated current |
| CCHigh Accuracy*2 LHM | 0.05% +/- (Ix0.1%) A |
| Constant Resistance Mode | |
| Transient Time Range : CRM / CRH | Same As CC Mode |
| Transient Time Range : CRL | Same As CV Mode |
| Temperature Coefficient : CRM / H | 300 ppm / °C of Minimum Resistance |
| Temperature Coefficient : CRL | 300 ppm / °C of Maximum Resistance |
| Constant Resistance Mode - Program | |
| CR Resolution*2 | 1/16000 of rated value |

| External Programming Mode | |
|----------------------------------|---|
| Monitor Output Signal | 0-10 Volts output for 0 to full scale value |
| VMON Accuracy | 0.10% +/- (Vx0.1%) V |
| IMON Accuracy | 0.10% +/- (Ix0.1%) A |
| Analog Program | 0~10 Volts Input yields 0 -- selected full scale loading in all modes |
| Accuracy | Same As Internal \pm 0.1% Rating |
| Input Impedance | 200 k Ω \pm 1 % |
| BandWidth(-3dB) | Limited By Internal Transient Time |
| Remote Interface | GPB / RS-232 / ETHERNET / USB |
| Programmable Protection | |
| Power (OPP) | |
| Range | (Px1.05/800) ~ (Px1.05) W |
| Resolution | (Px1.05/8000) W |
| Accuracy | 0.50% +/- (P x 21 / 8000) W |
| Voltage (OVP) | |
| Range | (Vx1.05/1600) ~ (Vx1.05) V |
| Resolution | (Vx1.05/16000) V |
| Accuracy | 0.20% +/- (Vx1.05/800) V |
| Current (OCP) | |
| Range | (Ix1.05/1600) ~ (Ix1.05) A |
| Resolution | (Ix1.05/16000) A |
| Accuracy | 0.20% +/- (Ix1.05/800) A |
| Under Voltage Lockout (UVL) | |
| Mode | Input On / Continuous |
| Range | ((V/4000*3) ~ Vmax) V |
| Resolution | (V/4000) V |
| Accuracy | 2.50% +/- (V/800) V |
| Anti-Oscillation | Default/ Osc1/ Osc2/ Osc3/ Disable |
| Protection | |
| Over Power (OP) | (Px1.05) +/- (Px0.02) W |
| Over Voltage (OV) | (Vx1.05) +/- (Vx0.02) V |
| Over Current (OC) | (Ix1.1) +/- (Ix1.1x0.01/1.05) A |
| Over Temp (OTP) | 90.00 +/- 5.000 $^{\circ}$ C |
| Reverse Max Current (RCP) | (Ix1.1) A |
| Short Max Current | (Ix1.02) A |
| Remote Inhibit (RI) | Short |
| Fault Indicator | SPDT Relay (30Vdc/0.5A or 125Vac/0.25A) |
| General | |
| AC Input | 95~240 Vac 48~62 Hz |
| Derating for higher temperatures | (-)1.67% Rated Power / $^{\circ}$ C |
| Operating Temperature | 5 $^{\circ}$ C ~ 40 $^{\circ}$ C |
| Transient Mode | |
| Frequency Range | 0.100 - 10,000 Hz |
| Duty Range | 1.000 - 100.0% |
| Transient Time Accuracy | 10.0% +/- 50% of Min Time |
| Dielectric Strength | |
| Primary Circuit To Chassis | 1500 Vac for 1 min |
| Primary Circuit To Load Terminal | 1500 Vac for 1 min |
| Load Terminal To Chassis | 1500 Vdc for 1 min |

- 1 – All Mode Specification measure by slow band and 25 $^{\circ}$ C room temperature unless otherwise specified
- 2 – Transient Mode Specification must be x2
- 3– Please contact AMETEK Technical Support for a full detail datasheet / power curve for a specific eLoad model.

| PLA Model | Weight [lbs] | Dimension WxHxL [inch] |
|-------------|-------------------|---------------------------|
| PLA800 | 28 | 19.5x17x3.50 |
| PLA1.5K | 28 | 19.5x17x3.50 |
| PLA2K | 70 | 24.5x17x5.25 |
| PLA2.5K | 70 | 24.5x17x5.25 |
| PLA3K | 70 | 24.5x17x5.25 |
| PLA4K | 104 | 24.5x17x7.00 |
| PLA5K | 104 | 24.5x17x7.00 |
| PLA6K | 135 | 24.5x17x10.5 |
| PLA7.5K | 135 | 24.5x17x10.5 |
| PLA10K | ≈105 – dual boxes | 24.5x17x7.00 – dual boxes |
| PLA15K | ≈135 – dual boxes | 24.5x17x10.5 – dual boxes |
| 15U Cabinet | ≈120 | 38.2x23.5x34.2 |
| 30U Cabinet | ≈250 | 38.2x23.5x63.5 |

PLA POWER CURVES

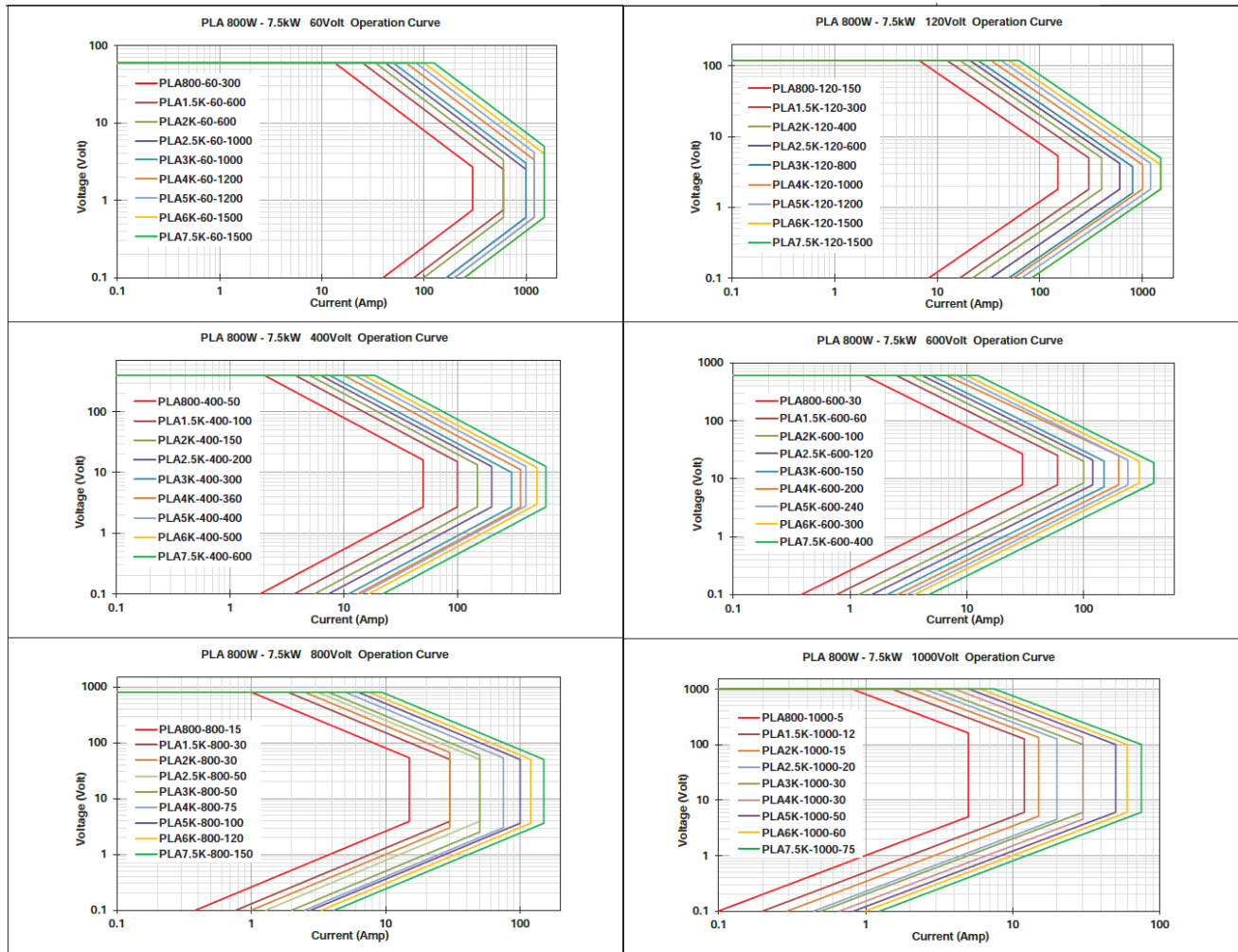

| PLW Model | Weight [lbs] | Dimension WxHxL [inch] |
|-----------|--------------|------------------------|
| PLW6K | 60 | 27.5x17x3.5 |
| PLW9K | 65 | 27.5x17x3.5 |
| PLW12K | 80 | 27.5x17x3.5 |
| PLW18K | 90 | 27.5x17x3.5 |
| PLW24K | 140 | 27.5x17x7.0 |
| PLW36K | 160 | 27.5x17x7.0 |

PLW POWER CURVES

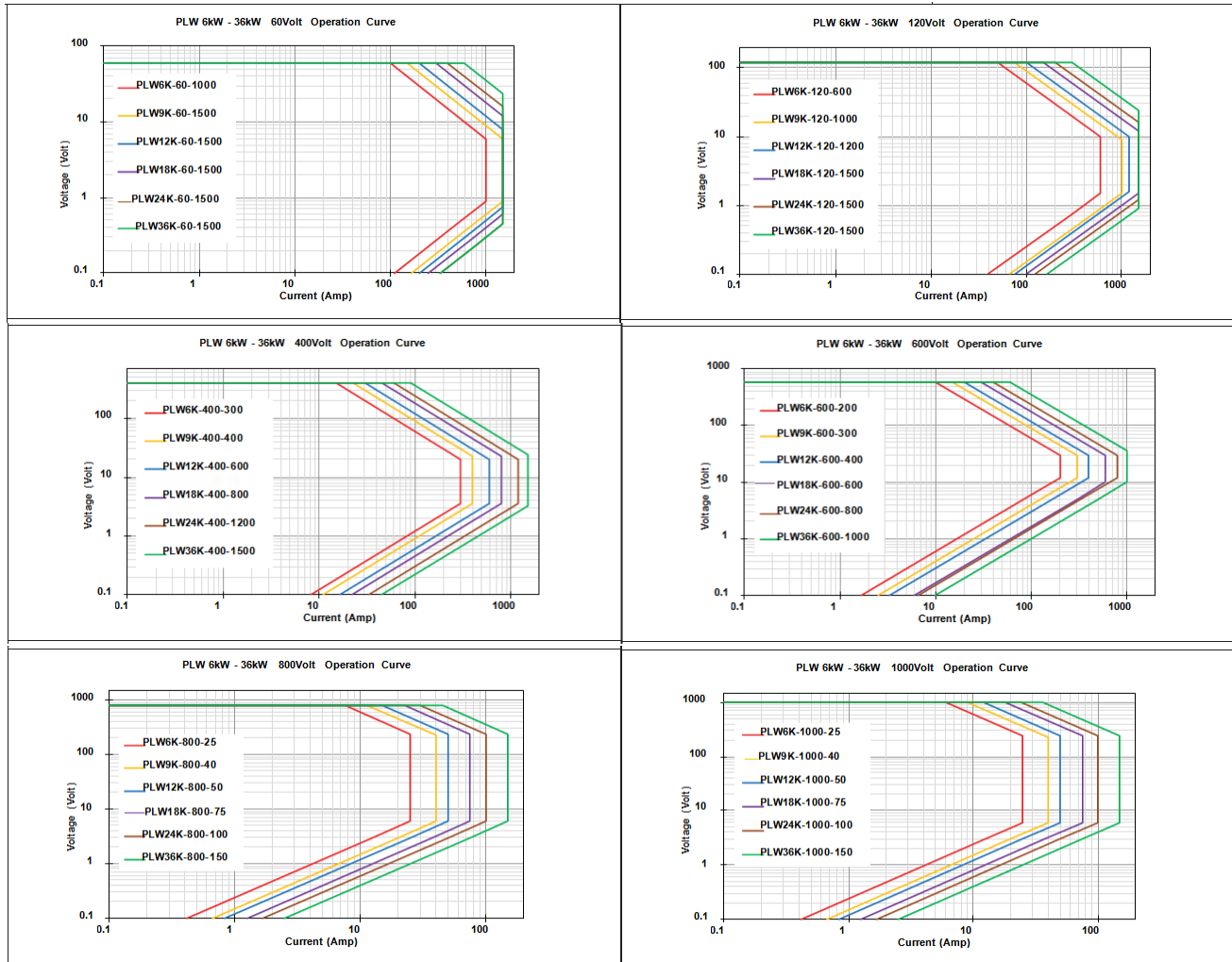

APPENDIX A: PEL & PLA/PLW COMMAND COMPATIBILITY TABLE

PEL & PLA/PLW Driver Compatibility Configuration

For PEL and PLA/PLW driver compatibility, the following procedures are needed.

1. Power on unit
2. Utility → Profile → Recall → 1
3. Recall profile 1
4. Exit Menu
5. Run ARPEL program (program can be installed from the driver file from the CD-ROM or the FTP site)
6. Configure GPIB address/RS-232 Speed
7. Click Start

The ARPEL program provides simple click and select menus to control functions on the load as well as a command prompt for entering SCPI commands.

PEL & PLA/PLW Command Compatibility Table

The table on the next page is to explain the difference between the PEL and PLA/PLW command syntax and parameters. Under the “PEL Syntax & Parameters” and “PLA/PLW Syntax & Parameters” columns, it lists the commands that will need adjustments when entering it. Please refer to the following table for PEL and PLA/PLW command syntax descriptions:

PEL & PLA/PLW PROGRAMMING COMMAND COMPATIBILITY CHART

| PEL COMMANDS | PLA & PLW COMMANDS | PEL Syntax & Parameters | PLA Syntax & Parameters |
|---------------------|---------------------|------------------------------------|--|
| INP[?] | INP[?] | | |
| INP[:STAT][?] | INP[:STAT][?] | | |
| SHOR | SHOR | | |
| INP:SHOR[:STAT][?] | INP:SHOR[:STAT][?] | | |
| SET[?] | SET[?] | | |
| VSET[?] | VSET[?] | | |
| VOLT[:LEV][:IMM][?] | VOLT[:LEV][:IMM][?] | | |
| VOLT[:LEV]:TRIG[?] | VOLT[:LEV]:TRIG[?] | | |
| ISET[?] | ISET[?] | | |
| CURR[:LEV][:IMM][?] | CURR[:LEV][:IMM][?] | | |
| CURR[:LEV]:TRIG[?] | CURR[:LEV]:TRIG[?] | | |
| RSET[?] | RSET[?] | | |
| RES[:LEV][:IMM][?] | RES[:LEV][:IMM][?] | | |
| RES[:LEV]:TRIG[?] | RES[:LEV]:TRIG[?] | | |
| PSET[?] | PSET[?] | | |
| POW[:LEV][:IMM][?] | POW[:LEV][:IMM][?] | | |
| POW[:LEV]:TRIG[?] | POW[:LEV]:TRIG[?] | - | |
| TR[?] | TR[?] | | |
| TLEV[?] | TLEV[?] | | |
| VTR[?] | VTR[?] | | |
| VOLT:TLEV[?] | VOLT:TLEV[?] | | |
| ITR[?] | ITR[?] | | |
| CURR:TLEV[?] | CURR:TLEV[?] | | |
| RTR[?] | RTR[?] | | |
| RES:TLEV[?] | RES:TLEV[?] | | |
| PTR[?] | PTR[?] | | |
| POW:TLEV[?] | POW:TLEV[?] | | |
| SLEW[?] | SLEW[?] | Check PEL Slew Rate Specifications | <p>1) PLA/PLW slew rate based on Slew Rate Specifications</p> <p>2) For PLA/PLW to PEL slew rate conversion, use the following conversion equation: $[(Trans\ Value - Main\ Value)/Desired\ Slew\ Time\ (ms)]\ (A/us)$</p> <p>(Note: This command will change both +/- Slew Rate Value)</p> |
| VOLT:SLEW[?] | VOLT:SLEW[?] | | |
| CURR:SLEW[?] | CURR:SLEW[?] | | |
| RES:SLEW[?] | RES:SLEW[?] | | |
| POW:SLEW[?] | POW:SLEW[?] | | |

| | | | |
|-----------------------|-----------------------|--|---|
| DUTY[?] | DUTY[?] | PEL Duty Range: 2~98 | PLA/PLW/LPL Duty Range 0~100 |
| VOLT:DUTY[?] | VOLT:DUTY[?] | | |
| CURR:DUTY[?] | CURR:DUTY[?] | | |
| RES:DUTY[?] | RES:DUTY[?] | | |
| POW:DUTY[?] | POW:DUTY[?] | | |
| FREQ[?] | FREQ[?] | PEL Frequency Range: 0.1 ~ 20 kHz | LPL/PLW/PLA Frequency Range: 0.1 ~ N kHz (N; maximum range value will vary by model) |
| VOLT:FREQ[?] | VOLT:FREQ[?] | | |
| CURR:FREQ[?] | CURR:FREQ[?] | | |
| RES:FREQ[?] | RES:FREQ[?] | | |
| POW:FREQ[?] | POW:FREQ[?] | | |
| MEAS:VOLT[:DC][?] | MEAS:VOLT[:DC][?] | | |
| MEAS:CURR[:DC][?] | MEAS:CURR[:DC][?] | | |
| MEAS:DEL[?] | MEAS:DEL[?] | | |
| VOLT:PROT:OVER[?] | VOLT:PROT:OVER[?] | | |
| CURR:PROT:OVER:[?] | CURR:PROT:OVER:[?] | | |
| POW:PROT:OVER:[?] | POW:PROT:OVER:[?] | | |
| VOLT:PROT:UND[?] | VOLT:PROT:UND[?] | | |
| CURR:PROT:UND[?] | CURR:PROT:UND[?] | | |
| POW:PROT:UND[?] | POW:PROT:UND[?] | | |
| VOLT:PROT:OVER:DEL[?] | VOLT:PROT:OVER:DEL[?] | | |
| CURR:PROT:OVER:DEL[?] | CURR:PROT:OVER:DEL[?] | | |
| POW:PROT:OVER:DEL[?] | POW:PROT:OVER:DEL[?] | | |
| VOLT:PROT:UND:DEL[?] | VOLT:PROT:UND:DEL[?] | | |
| CURR:PROT:UND:DEL[?] | CURR:PROT:UND:DEL[?] | | |
| POW:PROT:UND:DEL[?] | POW:PROT:UND:DEL[?] | | |
| VOLT:LIM:MAX[?] | VOLT:LIM:MAX[?] | | |
| CURR:LIM:MAX[?] | CURR:LIM:MAX[?] | | |
| RES:LIM:MAX[?] | RES:LIM:MAX[?] | | |
| POW:LIM:MAX[?] | POW:LIM:MAX[?] | | |
| VOLT:LIM:MIN[?] | VOLT:LIM:MIN[?] | | |
| CURR:LIM:MIN[?] | CURR:LIM:MIN[?] | | |
| RES:LIM:MIN[?] | RES:LIM:MIN[?] | | |
| POW:LIM:MIN[?] | POW:LIM:MIN[?] | | |
| MODE? | MODE? | PEL returns CV/CC/CR/CP | PLA returns VOLT/CURR/RES/P OW |
| MODE CC | MODE CC | | |
| MODE:CURR | MODE:CURR | | |
| MODE CV | MODE CV | | |
| MODE:VOLT | MODE:VOLT | | |
| MODE CR | MODE CR | | |
| MODE:RES | MODE:RES | | |
| MODE CP | MODE CP | | |
| MODE:POW | MODE:POW | | |

| | | | |
|------------------------------------|------------------------------------|---|--|
| MODE:RANGe <n> | MODE:RANGe <n> | | |
| MODE:RANGe? <MODE> | MODE:RANGe? <MODE> | | |
| SYST:RANGe[?] | SYST:RANGe[?] | | |
| UTIL:STEP:LOOP[?] <VAL> | UTIL:STEP:LOOP[?] <VAL> | 0 (Infinity) ~ 99 | 0 (Infinity) ~ 65535 |
| UTIL:STEP:COUNT[?] <VAL> | UTIL:STEP:COUNT[?] <VAL> | 1 ~ 99 | 1~256 |
| STEP:TIME[?] <STEP COUNT> <VAL> | STEP:TIME[?] <STEP COUNT> <VAL> | Step Count - 0~99; VAL (Step Time) - 10 ~ 600000 ms | Step Count - 1~256; VAL (Step Time) - 0 ~ 65535 ms |
| STEP:VALue <STEP COUNT> <VALUE> | STEP:VALue <STEP COUNT> <VALUE> | Step Count - 0~99; Step Value - Min to Max Value of Mode & Range | Step Count - 1~256; Step Value - Min to Max Value of Mode & Range |
| UTIL:MEAS:SENSE | UTIL:MEAS:SENSE | | |
| UTIL:EOI | UTIL:EOI | | |
| UTIL:TR:MODE | UTIL:TR:MODE | 0 – CONTINUOUS; 1 – STEPPING; 2 – PULSE; 3 – TOGGLE | 0 - TRIGger; 1 - CONTinuous; 2 - TOGGle; 3 - PULSe; 4 - STEP; 5 - AUTO; 6 - ONCE Note: Using PEL command to select transient mode will limit the transient operation to only PEL selections |
| UTIL:CURR[?] <VAL> | UTIL:CURR[?] <VAL> | | |
| UTIL:RANG[?] <VAL> | UTIL:RANG[?] <VAL> | | |

APPENDIX B: PLW – Cooling System Guidelines

1) GPM Requirements:

| Model Type | Water Temp (°C) | GPM | Model Type | Water Temp (°C) | GPM |
|------------|-----------------|-----|------------|-----------------|-----|
| PLW6K | 10°C | 2 | PLW36K | 10°C | 12 |
| | 15°C | 2.5 | | 15°C | 15 |
| | 20°C | 3 | | 20°C | 18 |
| PLW12K | 10°C | 4 | PLW48K | 10°C | 16 |
| | 15°C | 5 | | 15°C | 20 |
| | 20°C | 6 | | 20°C | 24 |
| PLW24K | 10°C | 8 | PLW60K | 10°C | 20 |
| | 15°C | 10 | | 15°C | 25 |
| | 20°C | 12 | | 20°C | 30 |

AMETEK recommends installing a Water Flow Meter to Monitor GPM Flow

2) PLW HEATSINK TEMPERATURE VS GPM CURVES

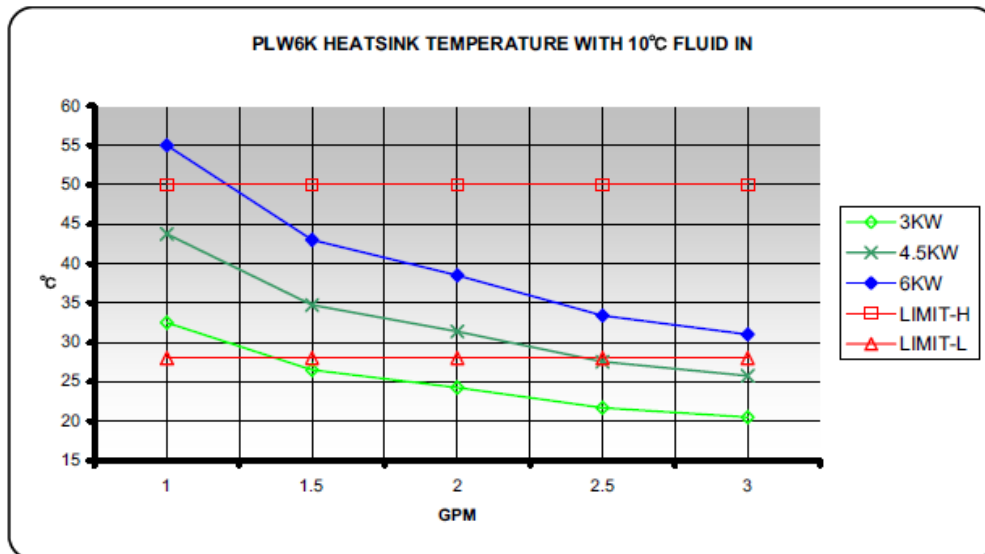

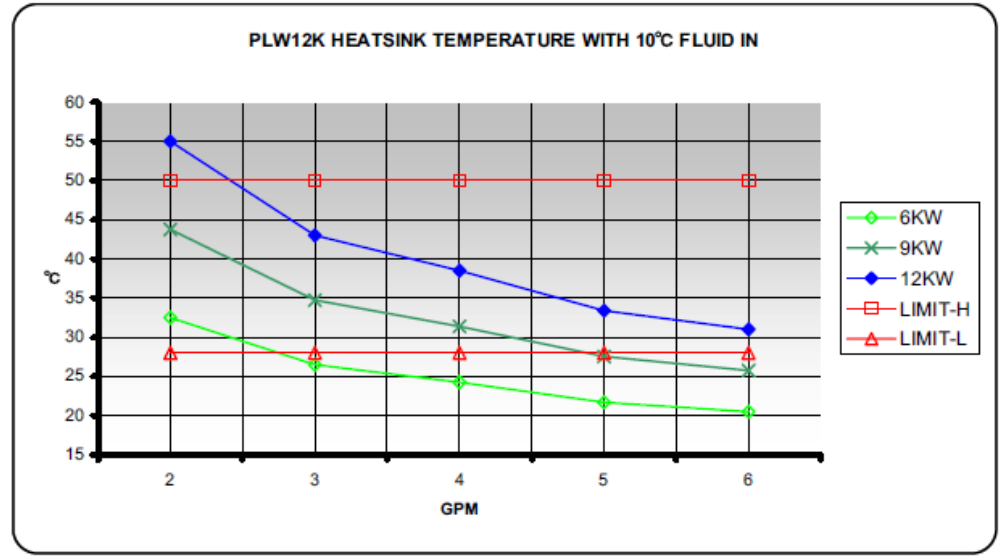
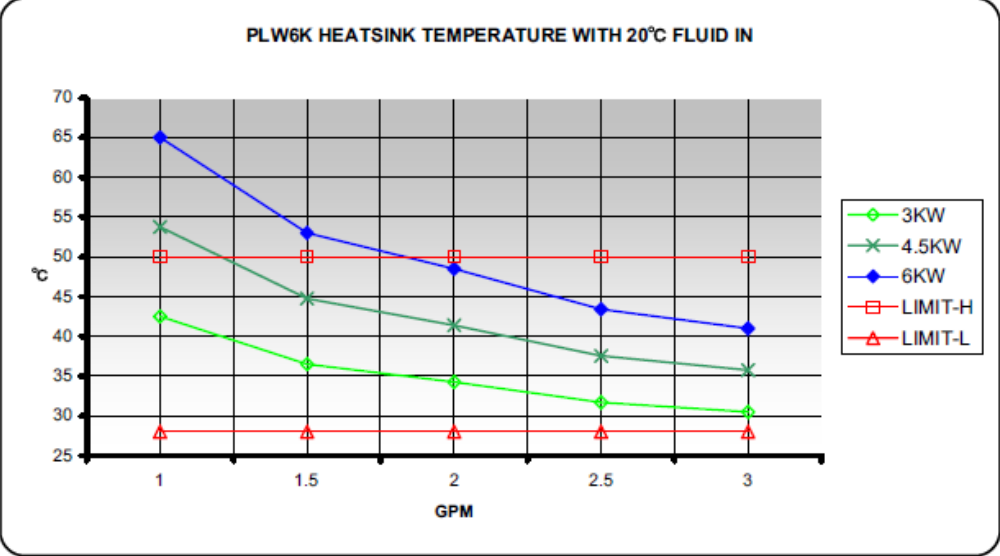
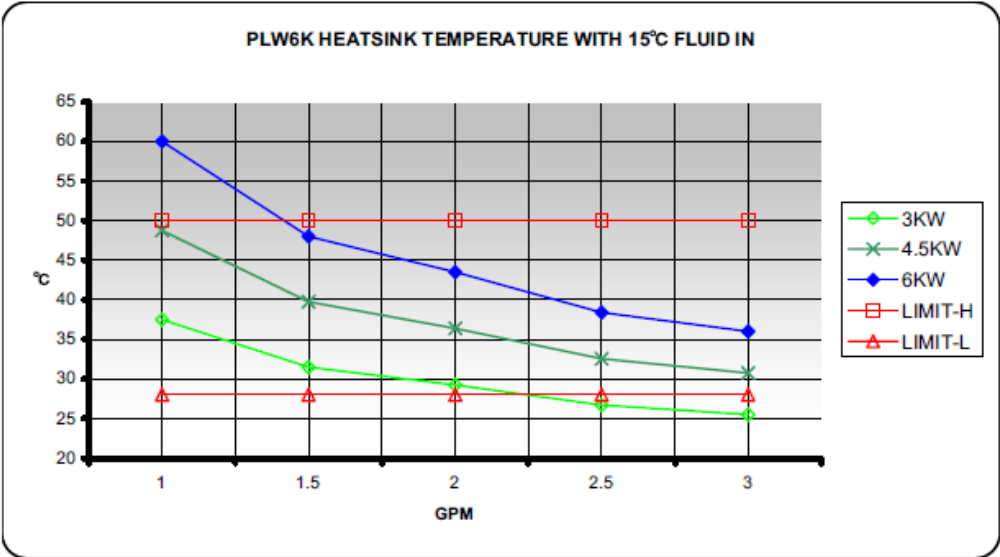

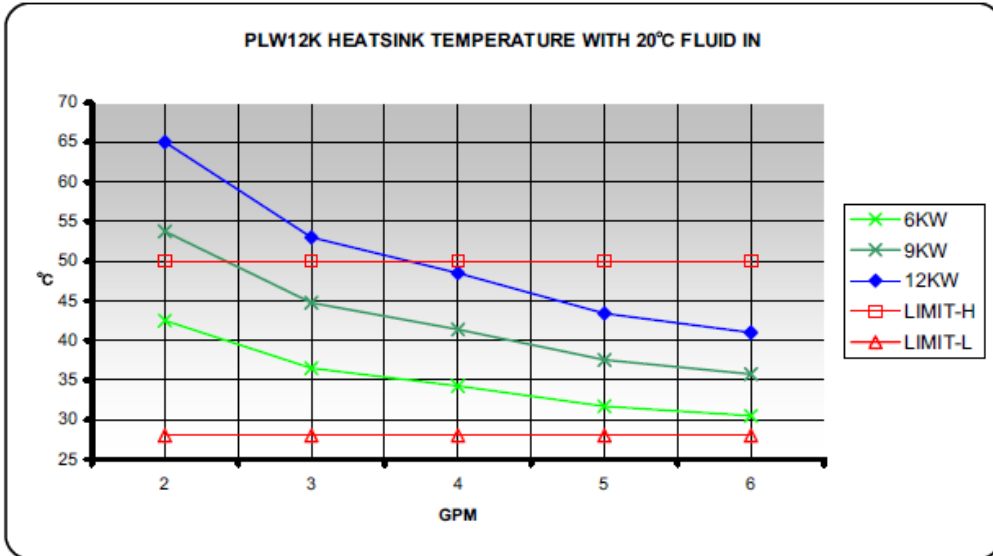
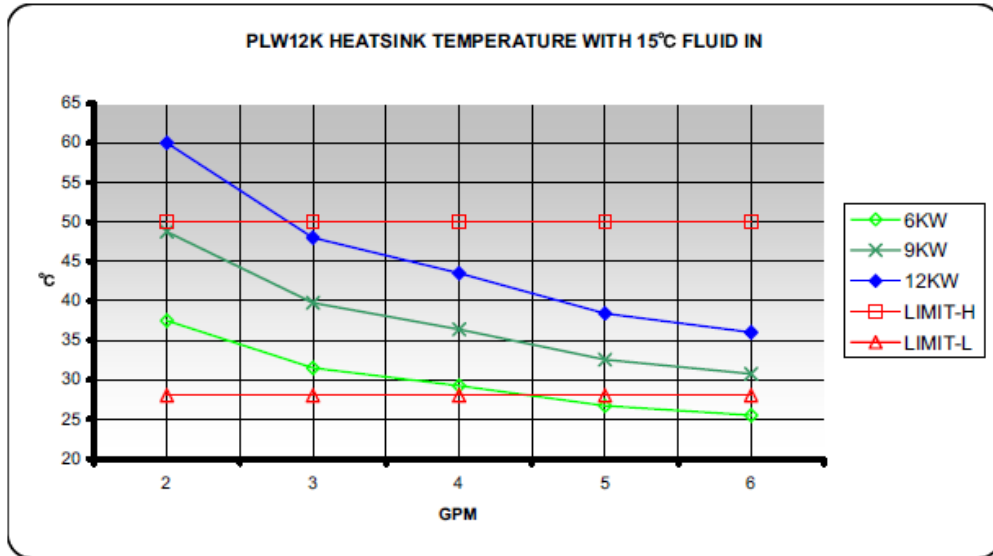

3) Pressure Requirements:

The Inlet Pressure or pressure differential should never exceed 70PSI. Please see below for additional precautions.

- A) Install a Pressure Regulator on the inlet end of the Water Cooling System. This will help regulate the inlet water pressure. The Honeywell DialSet® Pressure Regulating Valve is a good reference.
- B) There may be circumstances where the water valve is latched open due to excessive inlet pressure and GPM Flow. To identify this issue, simply monitor the water valve control system and listen for water flow once the valve indicator LED has darkened. The water flow should be impeded. If flow continues, reduce GPM flow and Inlet Pressure and continue to run test application. Monitor the front panel temperature reading (Go to Menu → Display → Meter Mode → **P+T**) and ensure it is operating below 40°C.

- C) As good practice, AMETEK Recommends the installation of inlet and outlet pressure meters to monitor the pressure differential in the system.

The recommended operating temperature of the eLoad is between 36°C ~ 40°C and lower. The GPM and Inlet Pressure can be adjusted to maintain the eLoad operating temperature within this range. Use the front panel temperature display to MONITOR the heat sink temperature, go to (MENU → DISPLAY → METER MODE → P+T).

As a rule of thumb, the water cooling requirements of the eLoad is a combination of pressure, GPM Flow, eLoad operating Temperature and eLoad Loading Level. The key is to monitor the water valve operation and eLoad temperature as a function of GPM Flow and Inlet Pressure. Please use the guidelines below and run a couple of iterations of the water cooling cycle - to ensure the water cooling system is operating normally.

- D) The Water Valve will conduct between 30°C ~ 34°C (Valve LED Illuminated)
 E) The Water Valve will close between 24°C ~ 28°C (Valve LED Off)
 F) eLoad Operating Temperature @ Full Power should be 36°C ~ 40°C (based on adequate GPM Flow and Pressure)
 G) Adjust GPM Flow & Pressure to maintain eLoad operating temp at 36°C ~ 40°C

Additional Liquid Cooling Specifications

PLW SERIES RECOMMENDED WATER PIPING INSTALLATION

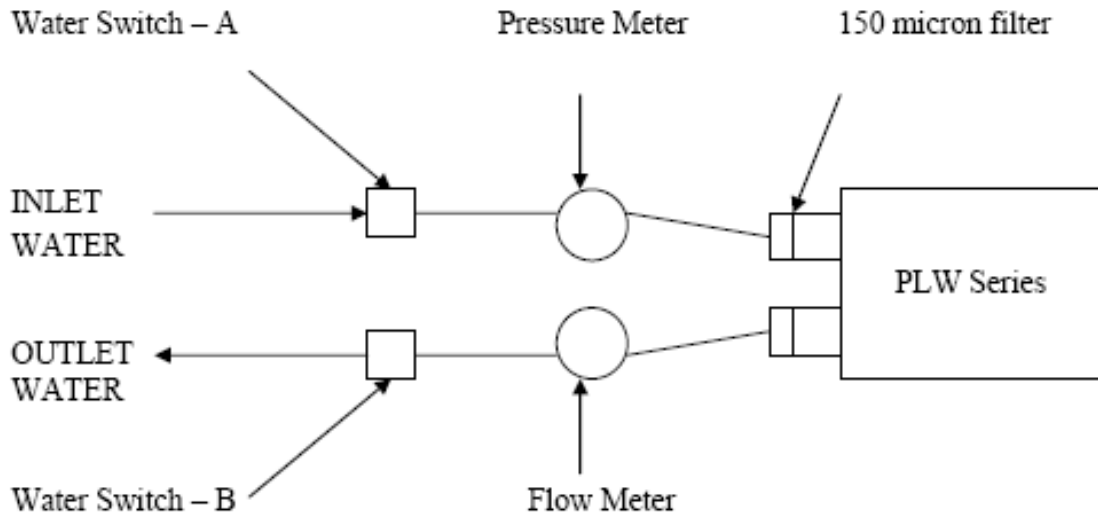

- A) It is recommended that the system be check for water leaks before operation.
 a. Check for water leaks by closing Water Switch – B.
 b. Then opening Water Switch – A.
 c. Turn the Load’s power ON and check for leaks (the power of the PLW must be ON in order for water flow into the load).
- B) Flow Meter’s inlet and outlet must be at least ½”.
- C) Install a 150-micron filter at the water inlet. (Recommend)
- D) Never allow water to flow from outlet to inlet.
- E) Inlet Coolant Temperature 5°C ~ 30°C

- F) AMREL recommends utilization of De-ionized/Distilled Water or non-corrosive coolants (pH level of 7)
- G) Water Viscosity greater than 50 CST
- H) When installing the inlet and outlet pipes, be careful not to over-torque the male pipe fittings into the Inlet/Outlet pipe terminals. This additional force may crack the inlet and/or outlet female piping on the eLoad.
- I) Water pressure must be less than 80 PSI in order for the valve to work properly.
- J) To remove water or fluid inside the unit completely, the valve can be manually turn on by supplying an external 12Vdc onto the unplugged 4pin green Valve connector. Insert air pressure less than 80psi from each FLUID INLET until no water or fluid coming out from FLUID OUTLET.

4) Anti-condensation Feature

Flow Control - The valve control system of the load is dependent of the heat sink temperature. When the heat sink temperature increases above 28°C, the water valve will turn on to decrease the temperature. When the heat sink temperature drops to 24°C, the valve will close. The valve acts as a switch to prevent the internal heat sink temperature from dropping below 20°C or lower temperatures that may cause condensation to occur.

5) Bypass water valve and Pressure Regulator

For new standard PLW system with manifold system, a pre-installed pressure release valve can be used to balance the inlet and outlet pressure, and it also can act as a water flow bypass. A pre-installed water pressure regulator maintains a constant pressure over a wide range of inlet supply pressures.

6) Maintenance – Liquid Solenoid Valve:

Required Maintenance Checks

As good practice, it is recommended to periodically check the liquid solenoid valves for clogs and sediment build-up that may impede or decrease liquid flow. Please reference the procedures below for liquid valve maintenance.

Liquid Valve Maintenance Check Procedures

- 1) Power off the unit, and release the water pressure from the piping system (water pressure will need to be released in order to prevent water from gushing out of the inlet/outlet pipe when disconnecting the water pipes). Locate the water valve on the rear panel of unit.



2) Unplug the 12V_{DC} connector (4 pin), remove the hexagonal nut and take off the coil assembly.

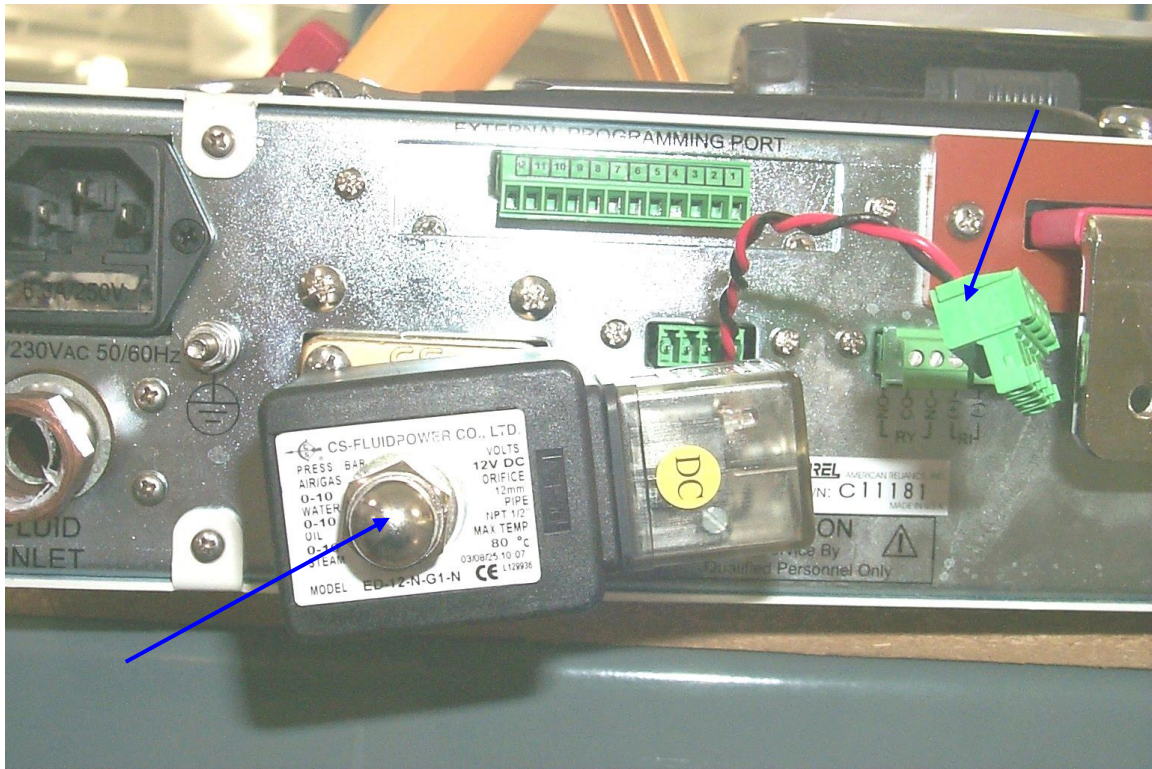



3) Remove the 4 screws securing the solenoid, and take off the solenoid assembly.





- 4) Locate the black rubber diaphragm, and remove it. (Do not forcefully remove the rubber diaphragm, it could be permanently damaged). After removing the solenoid valve assembly from the PLW unit, look for any residue or sediments that may be clogging the system, and ensure there are no build-ups around the internal components.

- 5) Ensure rubber diaphragm has an air-tight fit with the piping system, and connect the solenoid assembly back into place.
- 6) Fasten the screws slowly to make sure the four corners are balanced to prevent a leakage.

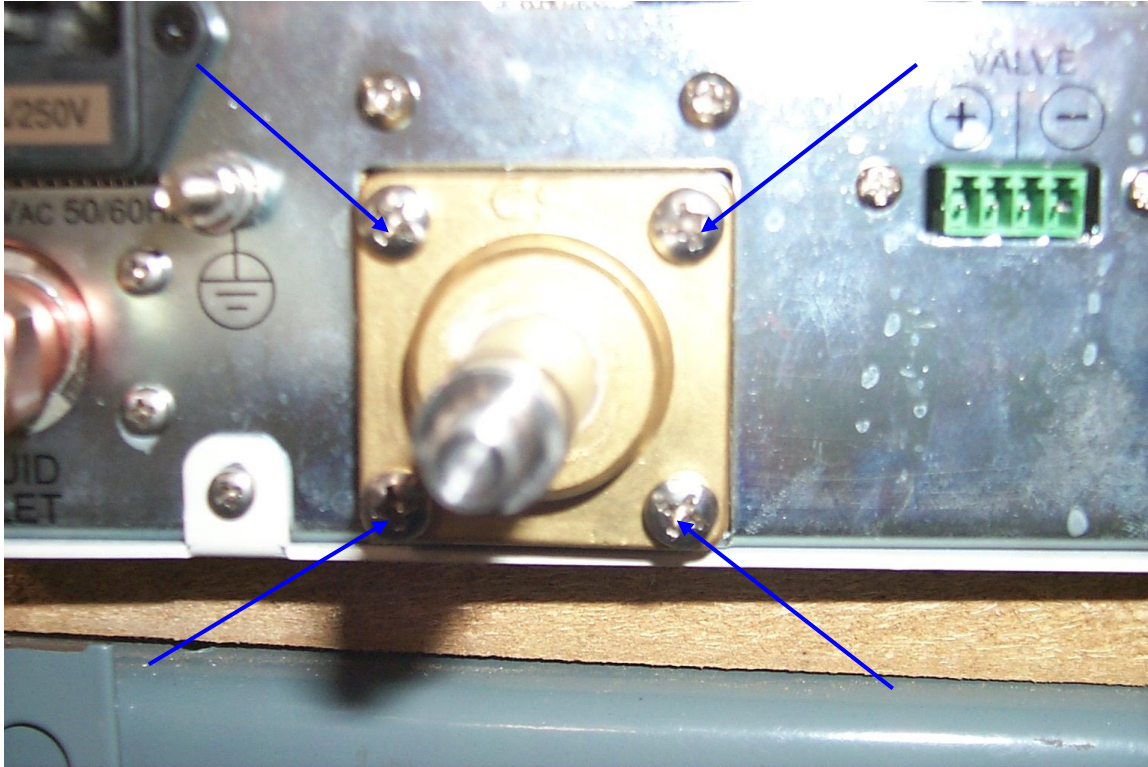

- 7) Place the coil assembly over the solenoid and re-bolt it tightly.

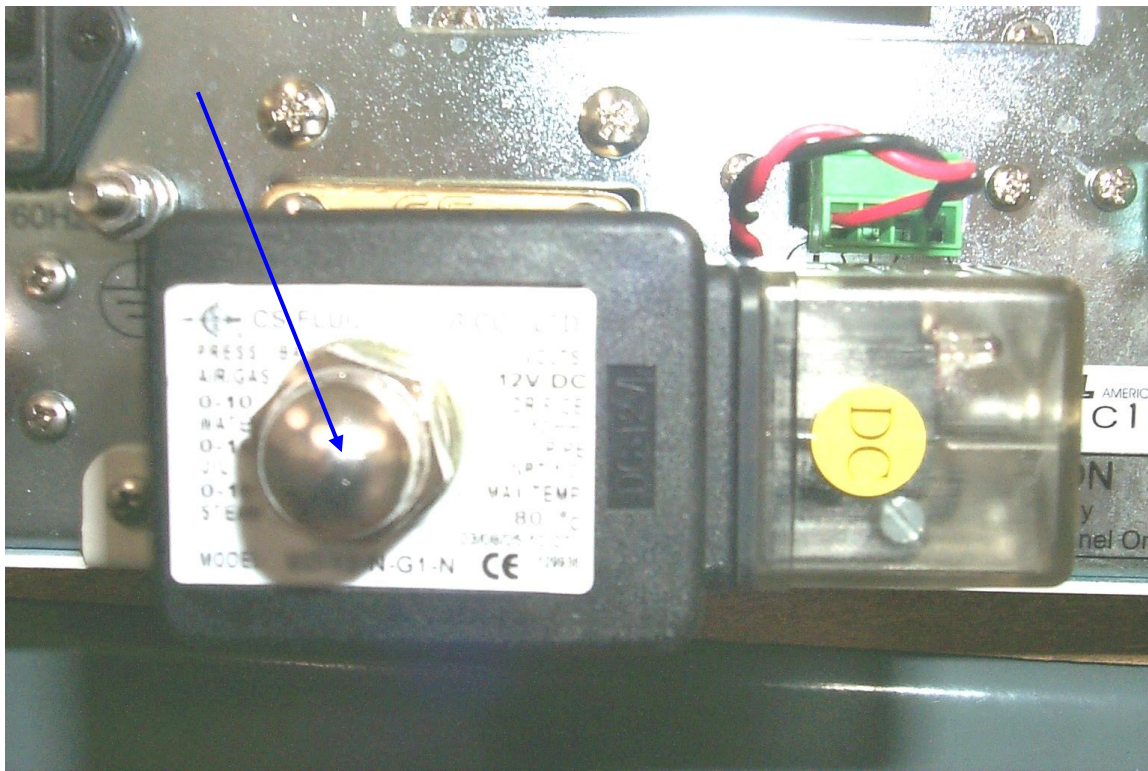

8) Now the rubber diaphragm has been replaced and the load is ready for operation.

Possible Failure Symptoms

For PLW loads, due to slight solenoid valve factory imperfections or improper usage, the rubber diaphragm of the water valve may tear after some usage and create a pressure leak. The result will cause a loud vibration sound, when the water valve is trying to turn on, due to the pressure leak, the valve will be unable to open properly. Generally, when a loud vibrating noise is heard from water valve during valve turn-on, there may be a defective rubber diaphragm, to verify please follow the procedures below.

Begin with Steps 1 ~ 4 in previous section, and then continue to Step 9 below.

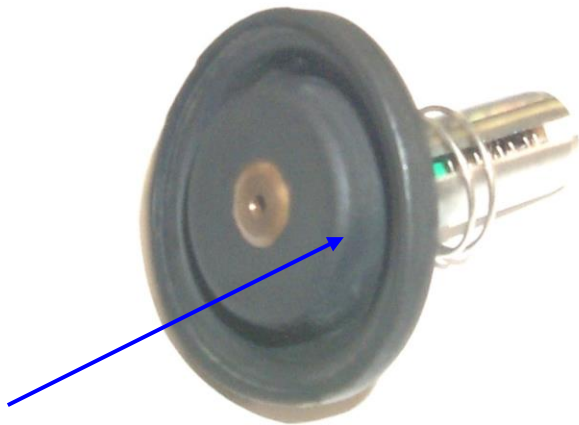

9) Separate the rubber diaphragm from the metal solenoid assembly.



10) Inspect the rubber diaphragm to verify the defect/damage.

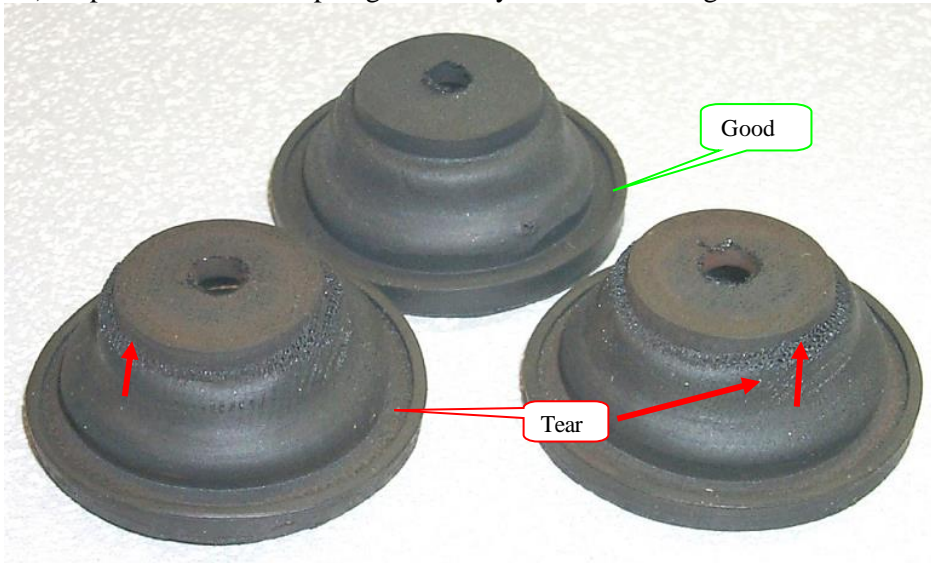

. A replacement will be
etal solenoid assembly.
groove (blue arrow).

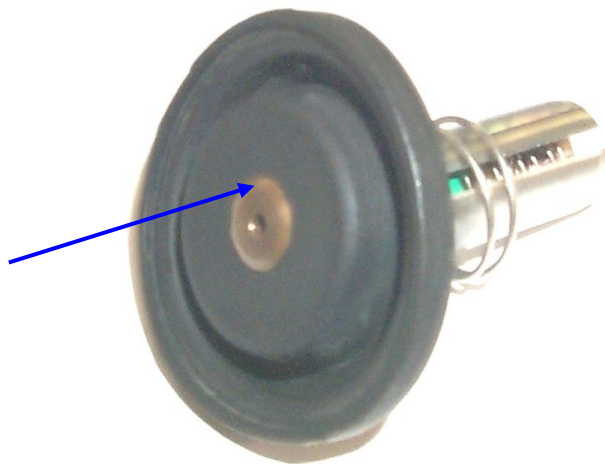

Now, follow steps 5 ~ 8 in the Maintenance Check Section to reinstall the solenoid valve assembly.

7) MANIFOLD-4U / External piping kit installation for PLW.

AMREL standalone 4U height Water-cooled eLoad unit is supplied with a coolant distribution kit. Due to the different cooling system requirements, the external piping kit is designed to convert two 3/8" NPT into one 1/2" NPT. To properly install the coolant distribution kit, please refer to the following directions carefully.

Components included:

- 1) FLUID INLET distribution pipe x 1pcs



- 2) INLET TOP interconnect pipe x 1pcs



- 3) INLET BOTTOM interconnect pipe x 1pcs



- 4) FLUID OUTLET distribution pipe x 1pcs



- 5) OUTLET TOP interconnect pipe x 1pcs



6) OUTLET BOTTOM interconnect pipe x 1pcs



7) Plastic Round Shim $\frac{1}{2}$ "ID, $\frac{3}{4}$ "OD, 0.003" Thick x 4 pcs



Installation Procedures:

Locate both the top and bottom FLUID INLET copper pipes.

Locate both the top and bottom FLUID OUTLET copper pipes.

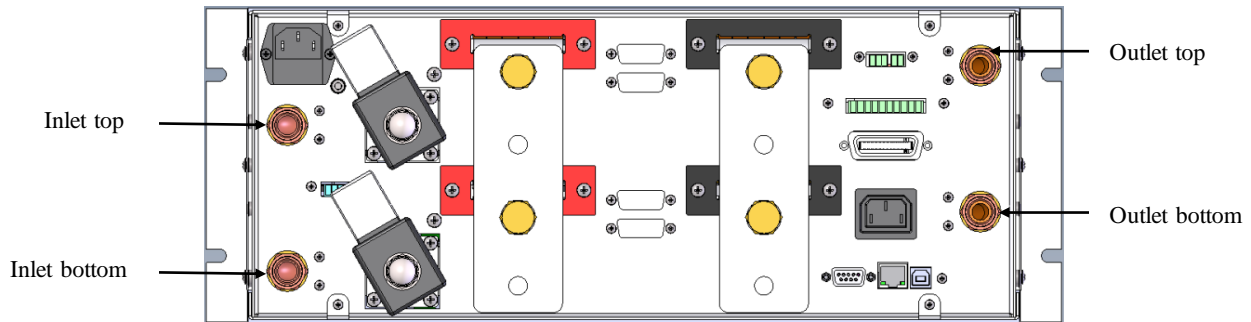

Use pipe thread sealant PTFE tape wrap approximately 3 to 4 times around each pipe male threads of each interconnect pipe, to ensure a tight seal and to prevent leak. Thoroughly clean the male and female thread and wrap the tap in the direction of the thread spiral. PTFE tape will not be included in the kit.



Install Plastic Round Shims (O-Rings) onto distribution pipes as picture below.

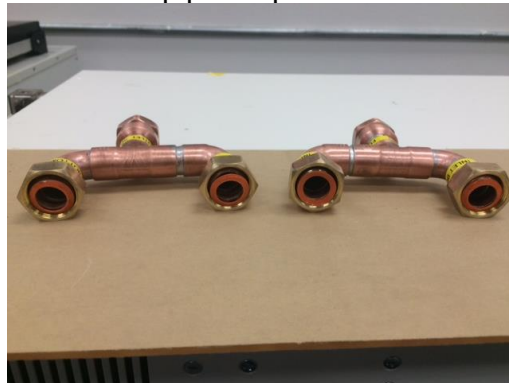
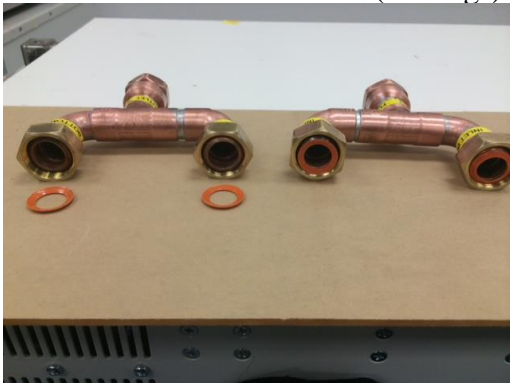

*Recommended tools: adjustable ranch x 2pcs

Install INLET TOP interconnect pipe to female threaded pipe at PLW rear panel.

Install INLET BOTTOM interconnect pipe to female threaded pipe at PLW rear panel. Using one ranch fixed position on the female threaded pipe at PLW rear panel, and the other ranch torque carefully at the interconnect pipe, Tighten the male end connection into the mating female end connection until hand-tight approximately 2 threads. Then tighten the male end connection until wrench-tight approximately 2 threads.

When installing the inlet and outlet pipes, be careful not to over-torque the male pipe fittings into the Inlet/Outlet pipe terminals. This additional force may crack the inlet and/or outlet female piping on the eLoad.



Locate the FLUID INLET distribution pipe. Install onto the interconnect pipes.

Using one ranch fixed position on the interconnect pipes, and the other ranch torque carefully at the distribution pipe.



Install OUTLET TOP interconnect pipe to female threaded pipe at PLW rear panel.
Install OUTLET BOTTOM interconnect pipe to female threaded pipe at PLW rear panel.
Using one ranch fixed position on the female threaded pipe at PLW rear panel, and the other ranch torque carefully at the interconnect pipe, Tighten the male end connection into the mating female end connection until hand-tight approximately 2 threads. Then tighten the male end connection until wrench-tight approximately 2 threads.



Locate the FLUID OUTLET distribution pipe. Install onto the interconnect pipes.
Using one ranch fixed position on the interconnect pipes, and the other ranch torque carefully at the distribution pipe.

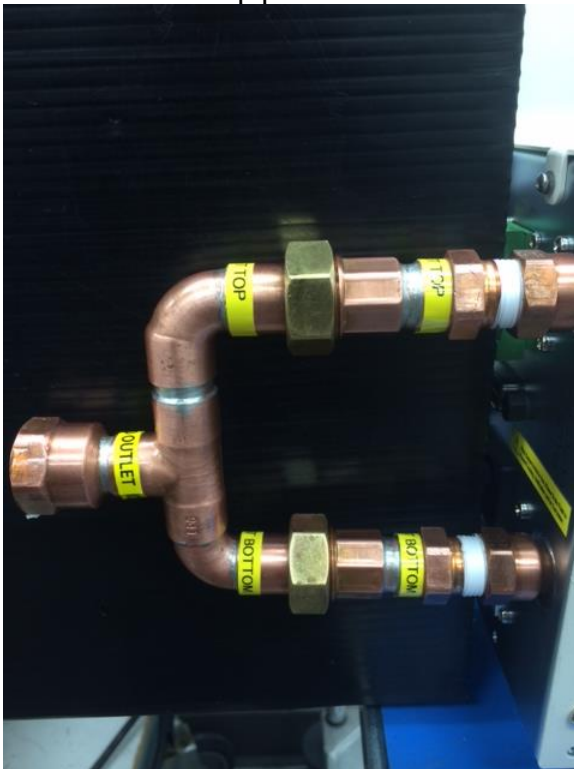

Installation Completed.

APPENDIX C: PV SWEEP - PC Software Guide

eLoad PV SWEEP & PV OPERATION GUIDE

Revision History

First release 1.0

Start Program

When click on the icon, an interface selection window is pop-up to select communication interface between PC and device. Please turn the knob to select interface, and change the interface parameters, and click the **OPEN** button to launch interface communication.

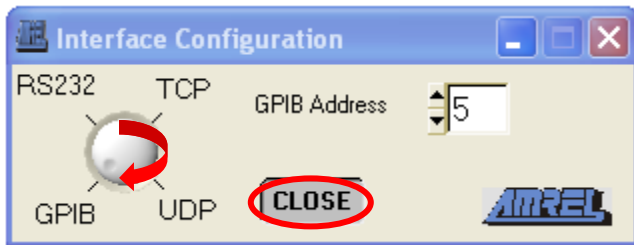

If interface successfully connect to eLoad device, control panel will pop-up for operation.

Access Control Panel

When interface successfully connect to device, a control panel will be displayed on the windows desktop.

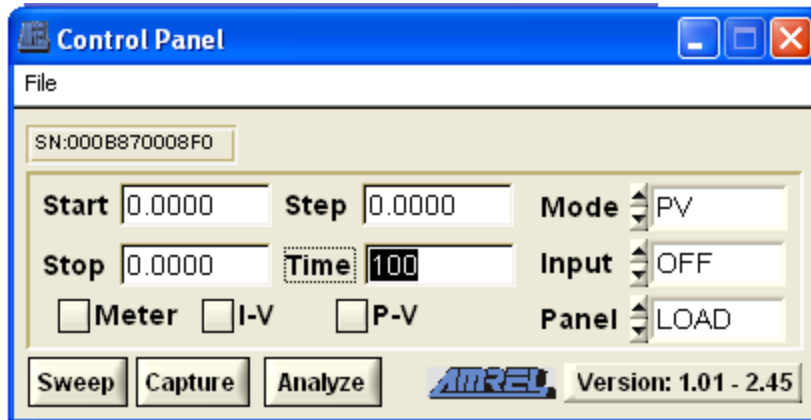

Note: For Solar PV testing, please use PV Mode

Sweep Operation & Data Capture

To start sweep operation, select sweep mode on **Mode** control, input sweep test case by entering specified values in **Start (Voltage)**, **Stop (Voltage)**, **Step (1mV ~ Vmax range)**, and **Time (100ms ~ 60s range)** control fields. The Step and Time parameters will configure the voltage increment and sampling time at

that voltage set point. Press **Sweep** button to launch sweep. While sweep is in operation, a message box



will show sweep state at the center of Window, until a pop-up box



notify

sweep operation is done successfully or has failed. If sweep operation is done successfully, system automatically start data capture operation to retrieve sampled data from devices, and accordingly captured data will be prompted to save into hard drive in .csv file format, where data capture can also be done by pressing



button.

Save PV (CSV) Data Prompt

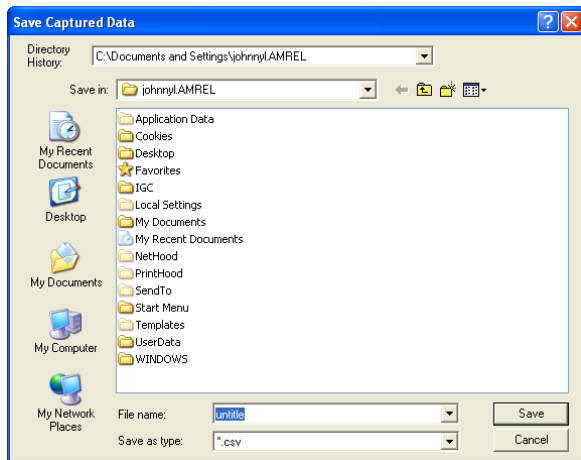

Two additional features for the PV Sweep Function:

| | |
|-------------------|--|
| Input OFF | Input Off: eLoad will not operate at max power point Input On: eLoad will operate at max power point |
| Panel LOAD | Panel Load: eLoad will resume back to normal operation Panel Sweep: eLoad will show P-V Sweep display |

Analysis by Graph

Captured data can be analyzed by pressing **Analyze** button.
The analyze function will provide 2 choices for data display:

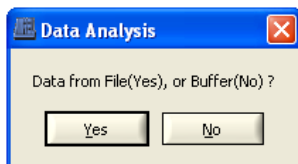

- 1) Data from File (Yes):** This will load previous test data stored on the PC hard drive
- 2) Data from Buffer (No):** This will load the current data stored in the PC Buffer

The P-V Sweep data will be presented on the P-V curve and I-V Sweep Data on the I-V Curve. Please disregard the I-V Curve data, which is used for other applications.

I-V curve

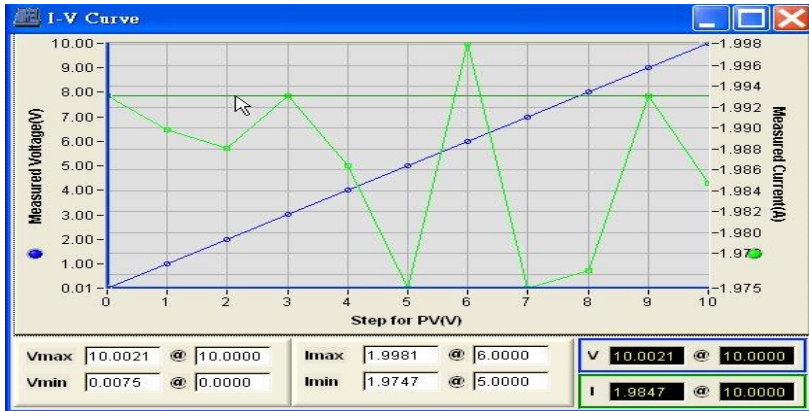

P-V curve (valid ONLY in PV mode)

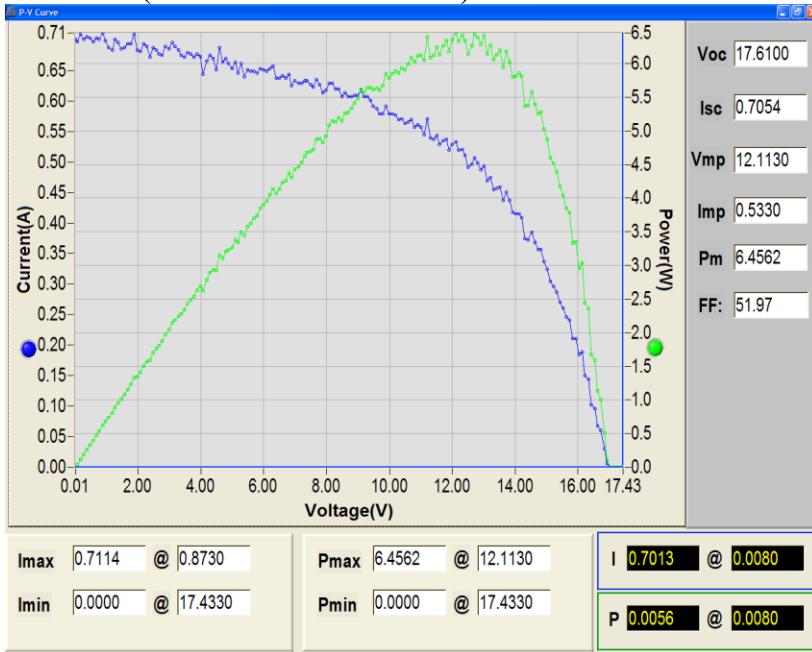

Device Identification and Version Information

Device identification is serial number of device shown at the right side of control panel which look like

SN:000B870004F6

, while version information is located at bottom of control panel and it look like

Version: 1.01 - 2.45

, where “1.01” is software version of this tool program, and “2.45” is device firmware revision number.

Meter & Graph Display Control

There are three bullets (shown below) which can be controlled by checking on the bullets to decide which graph or meter should be shown on desktop or hidden at background ,

Meter I-V curve P-V curve

(NOTE: P-V Curve bullet will ONLY exist in PV mode)

Profile Load & Save

Proofed test cases can be saved to disk as a .ini file for repeatedly accessing, which will backup/restore all parameters in Control Panel. Refer to **File->Profile** menu shown below.

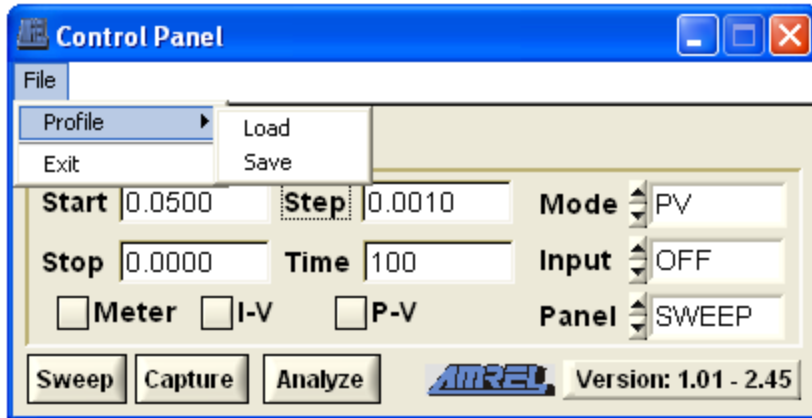

Descriptions of Meter, I-V Graph, and P-V Graph

While Meter can be shown on desktop when system connect to device. I-V graph, and P-V graph can ONLY be shown on desktop, when there are valid data captured by system.

Description of Meter

We can monitor device status by the measured voltage, measured current, and measured temperature shown on meter panel (see below), when we check bullet of meter Meter.

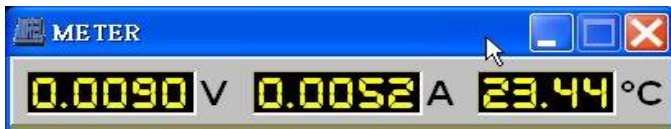

Description of I-V Graph

In the I-V graph (see below), X axis define configured value for each step of specified mode, left Y axis define measured voltage value, and right Y axis define measured current value.

The meanings for fields at the bottom of graph,

Vmax - maximum measured voltage. (@ at the right is its value of X axis)

Vmin - minimum measured voltage. (@ at the right is its value of X axis)

Imax - maximum measured current. (@ at the right is its value of X axis)

Imin - minimum measured current. (@ at the right is its value of X axis)

V - cursor values of left Y axis for measured voltage in blue color

I - cursor values of right Y axis for measured current in green color

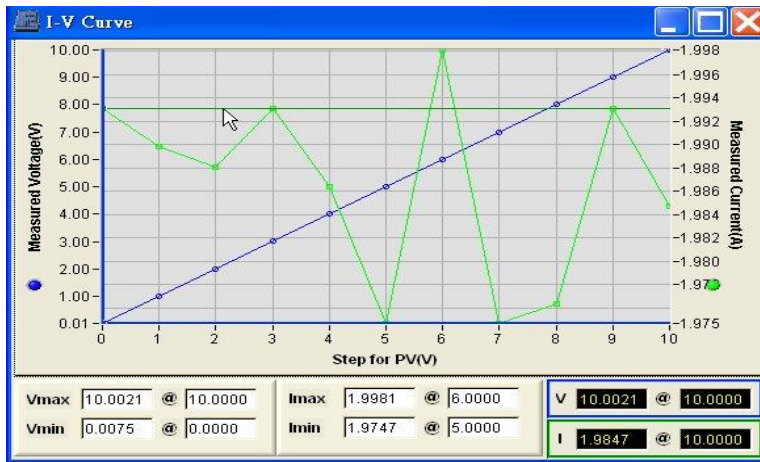

Description of P-V Graph

In the P-V graph (see below), X axis define measured voltage value for each step, left Y axis define measured current value, and right Y axis define measured power value.

The meanings for fields at the bottom of graph,

Imax - maximum measured current. (@ at the right is its value of X axis)

Imin - minimum measured current. (@ at the right is its value of X axis)

Pmax - maximum measured power. (@ at the right is its value of X axis)

Pmin - minimum measured power. (@ at the right is its value of X axis)

I - cursor values of left Y axis for measured current in blue color

P - cursor values of right Y axis for measured power in green color

The meanings for fields at the right side of graph,

Voc - open-circuit measured voltage.

Isc - short-circuit measured current.

Vmp - measured voltage at maximum power.

Imp - measured current at maximum power.

Pm - measured maximum power.

FF - fill factor(%)

