

Sorensen

Mi-BEAM Series

12.5 / 25 / 37.5 kW

0 to 2,000 V

± 50 to ± 150 A

Modular intelligent-Bidirectional Energy AMplified

High Performance, Bidirectional, Regenerative, Programmable DC Power System

Advanced Features

- Complete solution – Battery test, simulation and solar array simulator software included
- Highest power density up to 37.5 kW in 4U rack height (9.37 kW/U)
- Fastest and cleanest power available
 - Fastest transient response
 - Low output ripple and noise
- Universal 3-Phase AC Input accepts 180 VAC to 528 VAC
- 5 year warranty
- Parallel system power up to 8.6 MW+
- Series and Series split phase operation
- Output voltage up to 2,000 V
- Bidirectional output current up to ±150 A
- True extended auto ranging output
- Regenerative to 95%
- Built-in islanding detection
- Color touch panel user interface
- Seamless transition between source and sink



Applications

- Battery simulation
- Battery testing (charge/discharge)
- Electric powertrain testing
- Fuel cell testing
- Solar inverter testing

Performance. Power. Safety.

The Sorensen™ Modular Intelligent-Bidirectional Energy AMplified (Mi-BEAM) Series delivers high-power DC source and sink capabilities for advanced applications. With power levels from 12.5 kW up to 37.5 kW, the Mi-BEAM Series is scalable up to 8.6 MW+ in parallel. The available voltage ranges of 600V, 1,500V and 2,000 VDC in a 4U rack height chassis provide full power up to ±150A within a single system.

Control via Front Panel Touchscreen and Digital or Analog Control Interfaces

The Mi-BEAM Series can be operated from the intuitive, front panel touchscreen that enables the user to easily set up, control and monitor the Output Programming Parameters, Supervisory and Set Point limits, Measurements, and System Settings. Additionally, a variety of standard communication control interfaces are available including; LAN, USB, RS-232, CAN, Isolated Analog Programming and Monitoring, and Optional IEEE-488.

Featured Equipment Characteristics

- Standard modes of operation
- Bidirectional Mode (bi-DIR)
 - CV, CC, Series Resistance (CV mode only), CV/CC, CC/CV, CV/CP, CC/CP, CP/CC
- Source Mode (DC source only)
- Electronic Load Mode (eLoad)
 - Current, Power & Resistance Programming
- Battery Simulator Mode (BATSIM)
 - Charge/Discharge
- Battery Test Mode (BATTEST)
- Photovoltaic Simulator Mode (PVSIM)
- Automotive Standard Testing with LV 123 and LV 148
- Drive train testing with V-I characteristics for drive cycle tests
- Voltage/Current Ramps
- List/Waveform Generation
- Data Logging
- Remote Inhibits, Input/Output Triggers & Monitor Signals
- Firmware Updates via LAN
- Parallel Interface

Communication & Control Interfaces

Standard Communication Interfaces

- LAN (10 BASE-T and 100 BASE-T)
- USB 2.0
- RS-232C
- CAN
- Isolated Analog Programming and Monitoring
- SCPI Compliant Command Set
- IVI-C, IVI-COM and LabVIEW Drivers

Optional Communication Interfaces

- IEEE-488

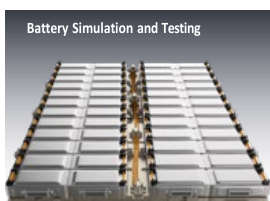

Specifications

The following sections provide electrical, environmental, and physical specifications for the Mi-BEAM DC Series power supplies.

Unless otherwise noted, the specifications are valid under the following conditions:

- Ambient temperature of $25 \pm 5^{\circ}\text{C}$, after a 30-minute warm-up, and at fixed AC input line and load.
- DC output into a resistive load.
- Specifications values are valid from 10% of the full-scale value.
- Stability is over an 8-hour period after a 30-minute warm up.
- If remote sense is used, then the output voltage accuracy, regulation and stability specifications are valid at the point where the remote sense leads are connected.

Output Power

The Mi-BEAM features a universal 3-Phase AC Input that accepts Nominal 200 VAC to 480 VAC inputs with an overall range of 187 VAC to 528 VAC. Output power ratings are dependent on the 3-Phase AC Input Voltage.

MODEL	AC INPUT VOLTAGE NOMINAL 380 – 480 VAC (RANGE 342 – 528 VAC)	AC INPUT VOLTAGE NOMINAL 200 – 240 VAC (RANGE 187 – 264VAC) ⁽¹⁾
Mi-BEAM Series Output	12.5 kW, 25 kW, 37.5 kW	6 kW, 12 kW, 18 kW
⁽¹⁾ When using the nominal Low Line Input range of 200 – 240 VAC the Output Power is derated to 50%.		

Output Voltage and Current Ratings

Output voltage and current ratings are offered with Auto Ranging characteristics.

The Auto Ranging feature provides expanded current and voltage range at the full output power level, enabling the ability to satisfy a wider testing need without requiring the purchase of additional models.

POWER	AC INPUT 342 – 528 VAC	12.5 kW	25 kW	37.5 kW
	AC INPUT 187 – 264 VAC	6 kW	12 kW	18 kW
Voltage (V)		Rated Current (A)		
600		50	100	150
1500		--	50	50
2000		--	50	50

Auto Ranging Output Voltage and Current Characteristics

For the rated power ratings, the auto ranging models provide expanded current range enabling the ability to satisfy wider testing needs.

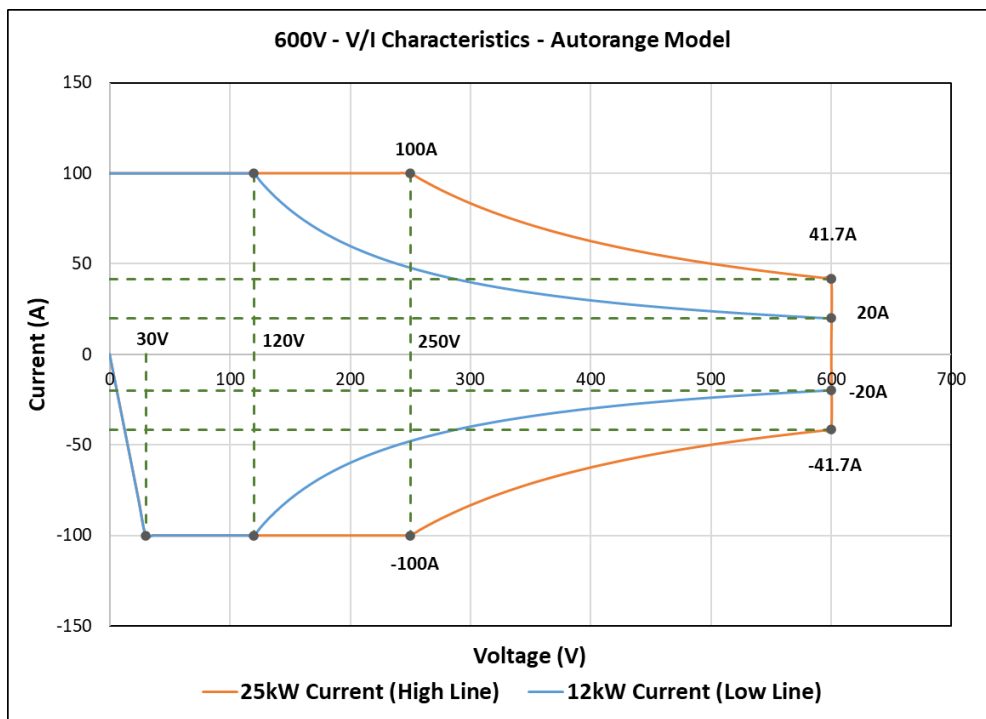
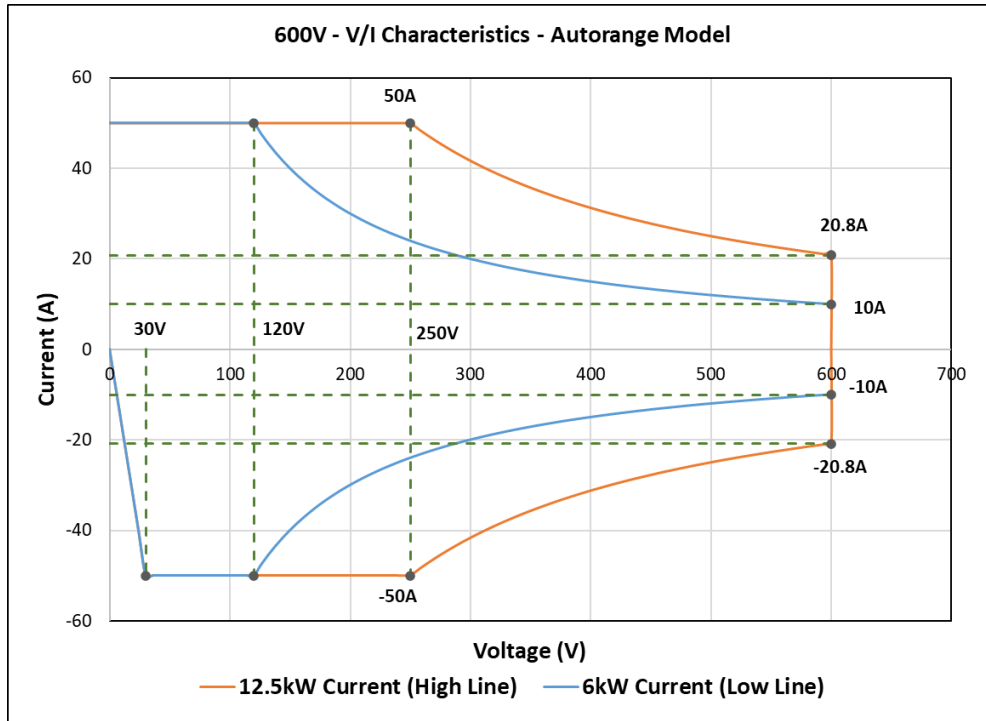

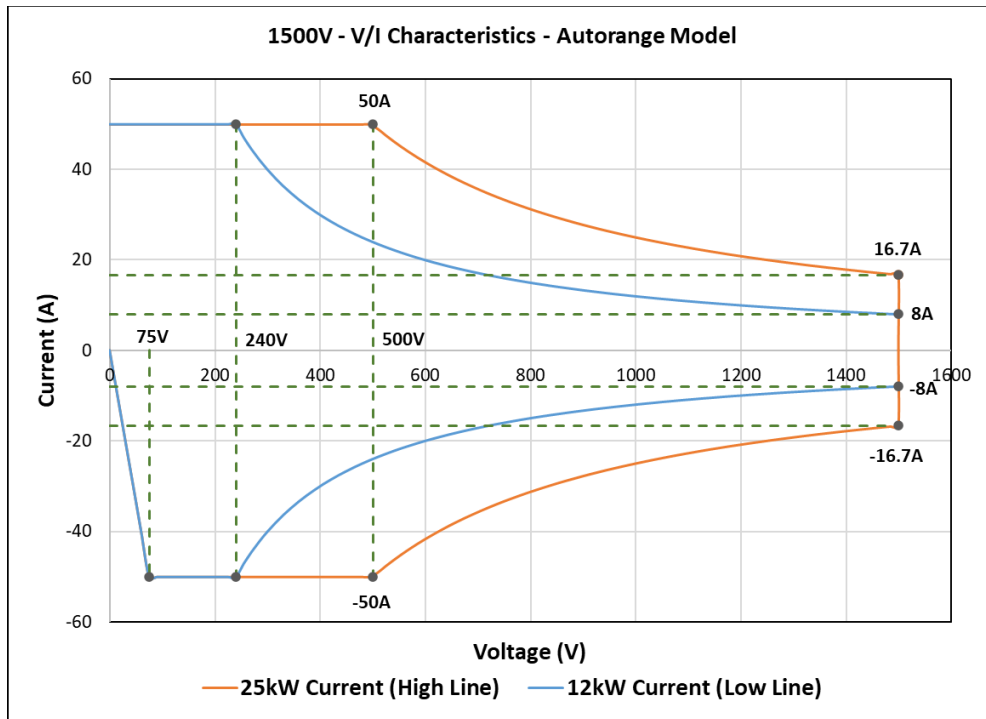
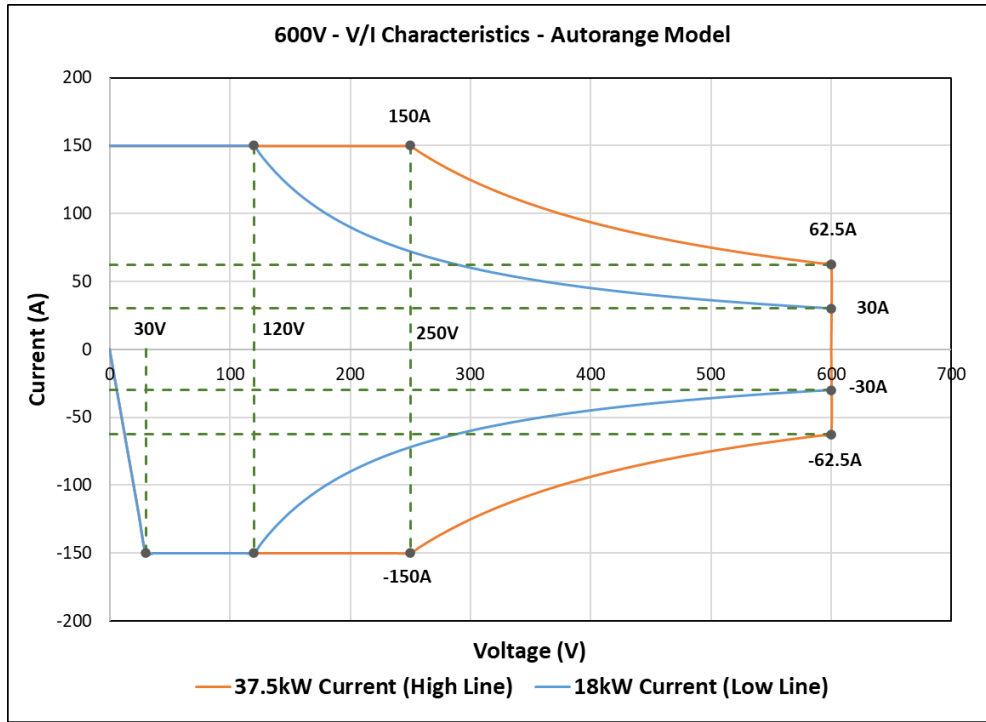

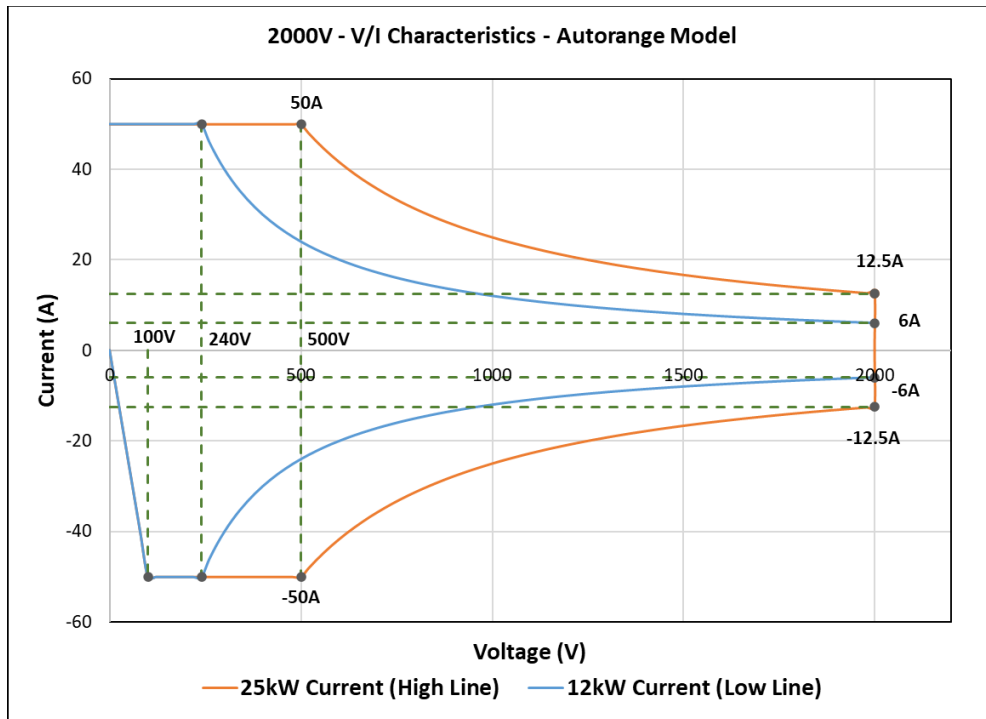
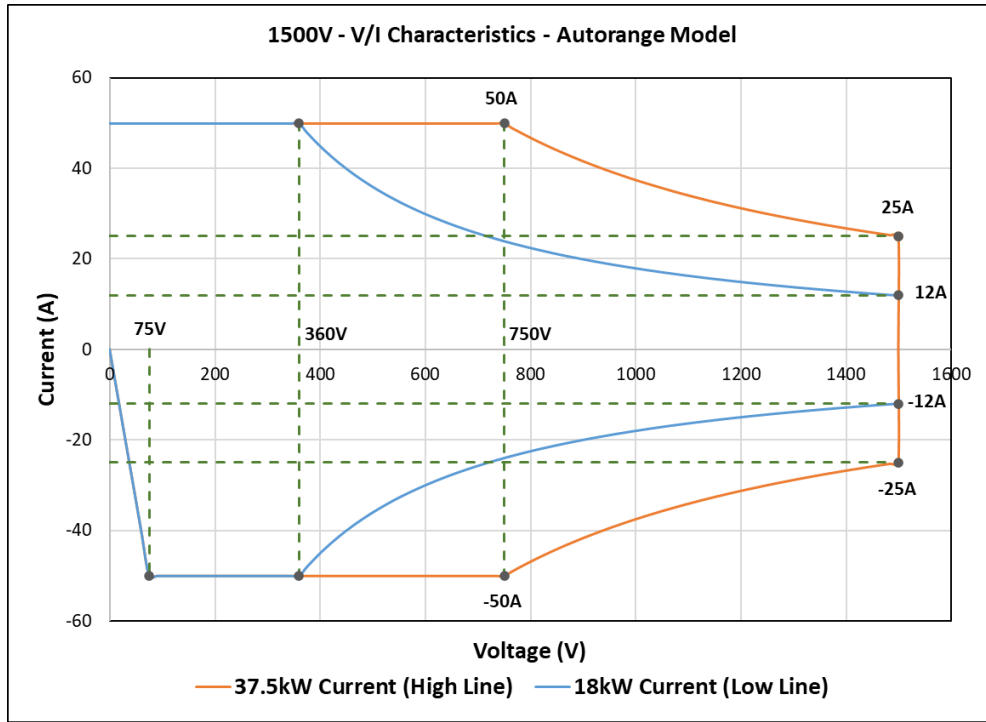

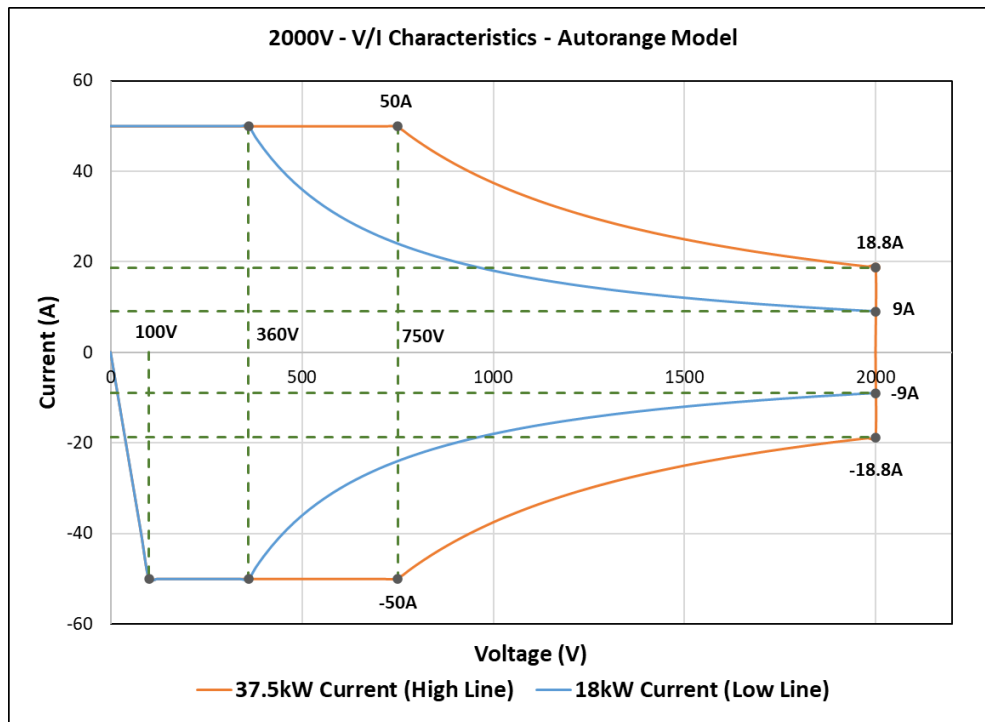

Resolution Specifications

RESOLUTION	REMOTE DIGITAL INTERFACE	FRONT PANEL
Voltage output programming set resolution	0.002% of full scale	5 Digits
Current output programming set resolution	0.002% of full scale	5 Digits
Power output programming set resolution	0.01% of full scale	5 Digits
Overvoltage programming set resolution	0.1% of full scale	5 Digits
Voltage output readback set resolution	0.002% of full scale	5 Digits
Current output readback set resolution	0.002% of full scale	5 Digits
Power output readback set resolution	0.01% of full scale	5 Digits

DC Output Programming, Readback and Regulation Specifications ⁽¹⁾⁽²⁾

PROGRAMMING & READBACK ACCURACY (VIA FRONT PANEL OR REMOTE DIGITAL INTERFACE)	
Voltage output programming accuracy	+/- 0.1% of rated output voltage
Current output programming accuracy	+/- 0.4% of rated output current
Power output programming accuracy	+/- 0.75% of rated output power
Overvoltage programming accuracy	+/- 1%, maximum, of rated output voltage
Voltage output readback accuracy	+/- 0.1% of rated output voltage
Current output readback accuracy	+/- 0.4% of rated output current
Power output readback accuracy	+/- 0.75% of rated output current
Overvoltage response time	20 ms
DC Regulation Characteristics – Constant Voltage (CV) Mode	
Maximum line regulation	+/- 0.01% of rated voltage
Maximum load regulation	+/- 0.02% of rated voltage
Temperature Drift	+/- 0.02% of rated voltage
Stability	+/- 0.05% of rated voltage

DC REGULATION CHARACTERISTICS – CONSTANT CURRENT (CC) MODE	
Maximum line regulation	+/- 0.05% of rated voltage
Maximum load regulation	+/- 0.08% of rated voltage ⁽³⁾
Temperature Drift	+/- 0.03% of rated voltage
Stability	+/- 0.05% of rated voltage
⁽¹⁾ Output voltage accuracy, regulation and stability specifications are valid at the point where the remote sense leads are connected. In the unit remote sense mode to be selected using front panel or the digital interface. ⁽²⁾ Regulation is measured with the rated power. ⁽³⁾ For 1500 V and 2000 V models, the load regulation specification is considered with respect to 2000 V rated voltage.	

eLoad Resistance Programming Range

At a given operating voltage Minimum and Maximum resistance is determined as follows:

- Minimum resistance = Operating UUT Voltage / (Maximum current at the operating voltage)
- Maximum resistance = Operating UUT Voltage / (1.6% of rated current)

POWER	AC INPUT 342 – 528 VAC	12.5 kW		25 kW		37.5 kW	
	AC INPUT 180 – 264 VAC	6 kW		12 kW		18 kW	
Voltage (V)	Minimum Operating Voltage for Maximum Current (V)	Min Res ⁽¹⁾ (Ω)	Max Res ⁽²⁾ (Ω)	Min Res ⁽¹⁾ (Ω)	Max Res ⁽²⁾ (Ω)	Min Res ⁽¹⁾ (Ω)	Max Res ⁽²⁾ (Ω)
600	30	0.6	750	0.3	375	0.2	250
1500	75	--	--	1.5	1875	1.5	1875
2000	100	--	--	2	2500	2	2500
⁽¹⁾ The minimum resistance value in this table is calculated at Minimum operating voltage. The minimum resistance value changes for each of the operating voltage and is calculated using the formula mentioned. ⁽²⁾ The maximum resistance value in this table is calculated at Maximum operating voltage. The Maximum resistance value changes for each of the operating voltage and is calculated using the formula mentioned.							

Remote Sense

REMOTE SENSE COMPENSATION	
Allowed Line Drop Voltage	2% of the rated output voltage
Connection	Voltage accuracy specifications apply at the point where the remote sense leads are connected.
Line Drop Effect on Output	There would be increased voltage equivalent to the line drop voltage at the terminals of the Power Supply.

Slew Rate Control Characteristics (User-Defined)

Models (V)	Voltage Regulation Operation ⁽¹⁾⁽²⁾ (V/ms)			Current Regulation Operation ⁽³⁾⁽⁴⁾⁽⁵⁾⁽⁶⁾ (A/ms)		
	12.5 kW	25 kW	37.5 kW	12.5 kW	25 kW	37.5 kW
600	60	60	60	100	200	300
1500	-	150	150	-	100	100
2000	-	200	200	-	100	100

- (1) Maximum rate of output voltage change is at constant output current.
- (2) In voltage regulation mode the maximum slew rate of load current should not exceed specified maximum current slew rate.
- (3) Maximum rate of output current change is at constant output voltage.
- (4) In current regulation mode the maximum slew rate of load voltage should not exceed specified maximum voltage slew rate.
- (5) In a paralleled system, the current slew will be multiplied by number of units in parallel.
- (6) Rate of change of output power must not exceed 'rated power of the unit' per 0.5 ms.

Transient Specifications – Voltage Regulation Operation

The transient specifications mentioned are bidirectional and assumes that load is changed such that the output voltage shall not exceed the maximum slew rate.

MODEL	VOLTAGE RISE TIME (ms), FULL LOAD ₍₁₎₍₃₎₍₇₎₍₈₎	VOLTAGE FALL TIME (ms), FULL LOAD ₍₂₎₍₃₎₍₇₎₍₈₎	VOLTAGE FALL TIME (ms), NO LOAD ₍₄₎	TRANSIENT RESPONSE (ms) ₍₅₎₍₆₎
600 V	10	10	10	1
1500 V	10	10	10	1
2000 V	10	10	10	1

- (1) Measured from 10%-90% of the output voltage change at rated resistive load - typical.
- (2) Measured from 90%-10% of the output voltage change at rated resistive load - typical.
- (3) In voltage regulation mode, the maximum slew rate of load current should not exceed specified maximum current slew rate.
- (4) Measured from 90%-10% of output rated voltage at No load – typical.
- (5) Typical time to recover within 0.75% of rated output voltage for load change of 50-100% of rated output current.
- (6) Typical overshoot and undershoot during the 50% load change would be within 10% of the rated voltage.
- (7) Unit must be configured to 'Slew mode – Fast' to achieve the mentioned rise/fall time in the table. If the configured rise/fall time is < 1.5 times the rise/fall time mentioned in the table, output power of the unit must be limited to 75% of the rated. If the configured rise/fall time is between 1.5 to 2 times the rise/fall time mentioned in the table, output power of the unit must be limited to 90% of the rated.
- (8) If unit is configured to 'Slew mode – Normal', the minimum rise/fall time of the unit will be limited to thrice the transient response time.

Transient Specifications – Current Regulation Operation

The transient specifications mentioned are bidirectional and assumes that load is changed such that the output current shall not exceed the maximum slew rate.

MODEL	CURRENT RISE TIME (ms), FULL LOAD (1)(3)(6)(7)(8)	CURRENT FALL TIME (ms), FULL LOAD (2)(3)(6)(7)(8)	TRANSIENT RESPONSE (ms) (4)(5)
600 V	0.5	0.5	0.5
1500 V	0.5	0.5	0.5
2000 V	0.5	0.5	0.5

- (1) Measured from 10%-90% of the output current change at constant rated voltage regulated by UUT - typical.
- (2) Measured from 90%-10% of the output current change at constant rated voltage regulated by UUT - typical.
- (3) In current regulation mode, the maximum slew rate of load voltage should not exceed specified maximum voltage slew rate.
- (4) Typical time to recover within 0.75% of rated output current for load change of 50-100% of rated output voltage.
- (5) Typical overshoot and undershoot during the 50% output voltage change would be within 15% of the rated current for 600 V, 12.5 kW model and 10% of the rated current for all other models
- (6) Unit must be configured to 'Slew mode – Fast' to achieve the mentioned rise/fall time in the table, in this slew mode output power of the unit must be limited to 85% of the rated.
- (7) If unit is configured to 'Slew mode – Normal', the minimum rise/fall time of the unit will be limited to twice the rise/fall time.
- (8) In paralleled system, the minimum rise/fall time remains same.

Output Voltage Ripple and Noise (applicable to Voltage Regulation Operation)

RATED OUTPUT VOLTAGE (V)	VOLTAGE RIPPLE & NOISE RMS, mV ⁽¹⁾	VOLTAGE RIPPLE & NOISE PK-PK, mV ⁽²⁾
600	120	500
1500	360	1500
2000	360	1500

(1) RMS ripple/noise, over 20 Hz to 300 kHz bandwidth, is measured directly across the output terminals with the supply operating into 90% of rated resistive load and nominal AC input line voltage.

RMS ripple is calculated using the below formula,
 V_{rms1} = RMS ripple measured when output is OFF
 V_{rms2} = RMS ripple measured with full load
 Effective RMS = $\sqrt{(V_{rms2})^2 - (V_{rms1})^2}$

(2) PK-PK ripple/noise, over 20 Hz to 20 MHz bandwidth with the supply operating into 90% of rated resistive load and nominal AC input line voltage.

PK-PK ripple is calculated using the below formula,
 V_{pk-pk1} = PK-PK ripple measured when output is OFF
 V_{pk-pk2} = PK-PK ripple measured with full load
 Effective PK-PK = $V_{pk-pk2} - V_{pk-pk1}$

AC Input Specification

PARAMETER	DESCRIPTION
Input Voltage Nominal range	AC Input Low Line: 3 phase, 3 wire + Gnd: ⁽¹⁾ Low Line Nominal rating range: 200 – 240 VAC, 3 Phase, Line-Line AC Input High Line: 3 phase, 3 wire + Gnd: High Line Nominal rating: 380 – 480 VAC, 3 Phase, Line-Line
Input Voltage, Operating range (AC Input: 3 phase, 3 wire + Gnd)	AC Input Low Line: 3 phase, 3 wire + Gnd: ⁽¹⁾ Low Line Operating rating range: 180 – 264 VAC, 3 Phase, Line-Line AC Input High Line: 3 phase, 3 wire + Gnd: High Line Operating rating: 342 – 528 VAC, 3 Phase, Line-Line
Input Current, Maximum RMS	AC Input Current Low Line: 3 phase, 3 wire + Gnd: 67 A at 180 VAC Line-Line AC Input Current High Line: 3 phase, 3 wire + Gnd: 67 A at 342 VAC Line-Line
Efficiency	AC Input Low Line: 3 phase, 3 wire + Gnd: 87-91% ⁽²⁾ AC Input High Line: 3 phase, 3 wire + Gnd: 93-95% ⁽³⁾
Inrush Current, typical ⁽⁴⁾	AC Input Low Line: 3 phase, 3 wire + Gnd: 100 A at 180 VAC Line-Line AC Input High Line: 3 phase, 3 wire + Gnd: 110 A at 342 VAC Line-Line
Input Frequency, Nominal Rating	50 Hz, 60 Hz
Input Frequency Range	47 Hz to 53 Hz, 57 Hz to 63 Hz
Power Factor ⁽⁵⁾ , typical	3-Ph: 0.99; active Power factor-controlled input rectifier
Isolation Test Voltage ⁽⁶⁾	2100 VDC Input to Ground
⁽¹⁾ For Low Line AC input voltage output power is derated to 50%. ⁽²⁾ Typical value at full load 18 kW output and nominal AC input voltage of 208 VAC L-L at 50/60 Hz input frequency. ⁽³⁾ Typical value at full load 37.5 kW output and nominal AC input voltage of 480 VAC L-L at 50/60 Hz input frequency. ⁽⁴⁾ Not including EMI filter inrush less than 200 us. ⁽⁵⁾ Measured at full load at rated three phase nominal AC input voltage of: 380 VAC, 400 VAC, 480 VAC L-L for input High Line 208 VAC L-L for input Low Line. ⁽⁶⁾ Isolation test can be conducted only in factory.	

Output Capacitance⁽¹⁾

MODEL (V)	RATED POWER		
	12.5 kW	25 kW	37.5 kW
600	360 uF	360 uF	360 uF
1500	-	40 uF	40 uF
2000	-	40 uF	40 uF

⁽¹⁾ Capacitance values mentioned with $\pm 10\%$ tolerance.

Operational Characteristics

PARAMETER	CHARACTERISTIC
Bidirectional Mode	In bi-DIR Mode the power can flow from power supply to UUT and vice versa (2 quadrant operation). The output current or voltage is regulated with these possible regulations: CV, CV/CC, CV/CP, CC, CC/CV, CC/CP, CP/CC . Refer to operations manual for more details regarding regulation. There is also a series resistance mode, depending on the current output the terminal voltage would be varied depending on the voltage drop across the series resistance. If the output current reaches the programmed limit the output voltage is programmed to zero.
Source Mode	In Source Mode , the power can flow only from the power supply to UUT, the output current or voltage is regulated with these possible regulations: CV, CV/CC, CV/CP, CP/CV, CC, CC/CV, CC/CP, CP/CC. Refer operations manual for more details regarding regulation. There is also a series resistance mode, depending on the current output the terminal voltage would be varied depending on the voltage drop across the series resistance. If the output current reaches the programmed limit the output voltage is programmed to zero.
eLoad Mode	In eLoad Mode , power flow is from output of the power supply to the Input AC-Grid, the output current or voltage is regulated with these possible regulations: CV, CV/CC, CR/CV, CP/CV, CV/CP, CC, CC/CV, CR/CC, CP/CC, CC/CP. Refer operations manual for more details regarding regulation. In this mode, output voltage is regulated by the UUT, and the output current drawn by the supply from the UUT can be programmed in three possible types: Current Programming, Power Programming and Resistance Programming.
Battery Simulation Mode	In this mode, different battery characteristics can be simulated. The user can choose either from built in battery models of commonly used battery types or customized battery models. The required characteristics of charge and discharge operation can be fine-tuned using various battery parameters including the ability to import Voltage vs SOC data. Allows seamless dynamic transition from charge to discharge and vice versa.

PARAMETER	CHARACTERISTIC
Battery Testing Mode	In this mode, the required charge/discharge characteristics are applied to the UUT by the power supply. Users can create multiple charging and discharging profiles which can be sequenced to achieve the required battery test conditions. Allows seamless dynamic transition from charge to discharge and vice versa.
Solar PV Array Simulator Mode	In this mode, the PV curve of a solar array is applied by the power supply by operating in source-current mode to the UUT such as an inverter. PV array simulator simulates MPPT and various real-world PV array scenarios for testing the inverter. Includes EN50530 and Sandia SAS models.
Automotive Standard Testing	Pre-defined test sequences for partial compliance in accordance with LV 123 and LV 148 within the slew rate limitations specified for the supply. Tests such as injecting high frequency voltage ripple would require additional equipment.
Drive Train Testing	Drivetrains can be tested by operating the power supply in bi-DIR mode. The power supply is used to analyze the characteristics of the drive with the ability to regenerate power back to AC Grid during braking of the drive train. Includes V-I characteristics programming to support standardized drive cycle tests.
Front Panel Controls	Enhance front panel touch display for the unit enables control and programming of output.
	Organized menus to support Output Programming, Measurements, Power on Settings, Communication Controls & System Settings, External Analog interface, Voltage and Current ramp functions.
Voltage Ramp	Voltage Ramps can be generated with a programmable Dwell, Start and End Voltage set points. Dwell time could be set to 1 ms minimum and 9999s maximum. Maximum slew to be limited as per the slew rate specifications of the output model.
Current Ramp	Current Ramps can be generated with a programmable Dwell, Start and End Current set points. Dwell time could be set to 1 ms minimum and 9999s maximum. Maximum slew to be limited as per the slew rate specifications of the output model.
List/ Waveform Generation Function	The list function allows the user to set up the supply to automatically run a series of voltage, current and power mode operations. This is especially useful for setting up the supply to test to compliance standards or unburdening the test computer in automated testing applications. Through RS-232, IEEE-488 or Ethernet, an external computer can trigger the list. Up to 50 lists may be stored, with each list containing up to 50 individual steps. With an extensive list of step functions such as ramping and looping user can define a variety of test sequences.
Fault Identification	On-board diagnostics identify when power supply has experienced a fault.

PARAMETER	CHARACTERISTIC
Programming Command Set	SCPI compliant command set and same could be used using all the communication interfaces (USB, RS232, Ethernet, CAN and IEEE-488).
Graphical User Interface (Virtual Panel)	Virtual panels allow programming and monitoring of Mi-BEAM power supply remotely. GUI supports all the operational modes such as bi-Directional, Source, eLoad, Battery Simulation, Battery Test and Solar Array Simulation. It also supports Output Programming, Measurements, Power on Settings, Communication Controls & System Settings, External Analog interface, Voltage and Current ramp functions, List/Waveform generation function, Data Logging function.
Software Drivers	IVI-C and IVI-COM, LabVIEW drivers provided for user programming,
GPIB interface, Option	Parallel interface complies with IEEE-488.1, IEEE-488.2, and the SCPI command specification.
Parallel Operation	Units with identical voltage ratings must be connected in parallel. Units with different model numbers can still be paralleled if their voltage ratings are the same. Outputs to be hardwired to the load from the relevant paralleled output terminals. Up to 32 units can be paralleled, enabling power levels up to 1200 kW.
Series Operation	Units with identical model numbers can be connected in series, i.e. the voltage, current and power ratings of the units must be same. Outputs to be hardwired to the load from the relevant series output terminals. Only 2 units with same model number can be connected in series. Series split phase operation allows user to connect to a load with a common terminal. For more details regarding series operation and connection, refer to operations manual.
Analog Programming	Provides Isolated Analog interface to program output.
Calibration	Calibration interval is 1 year; calibration is firmware-based through the SCPI commands using communication interface or Virtual Panels.

Front Panel Controls And Indicators

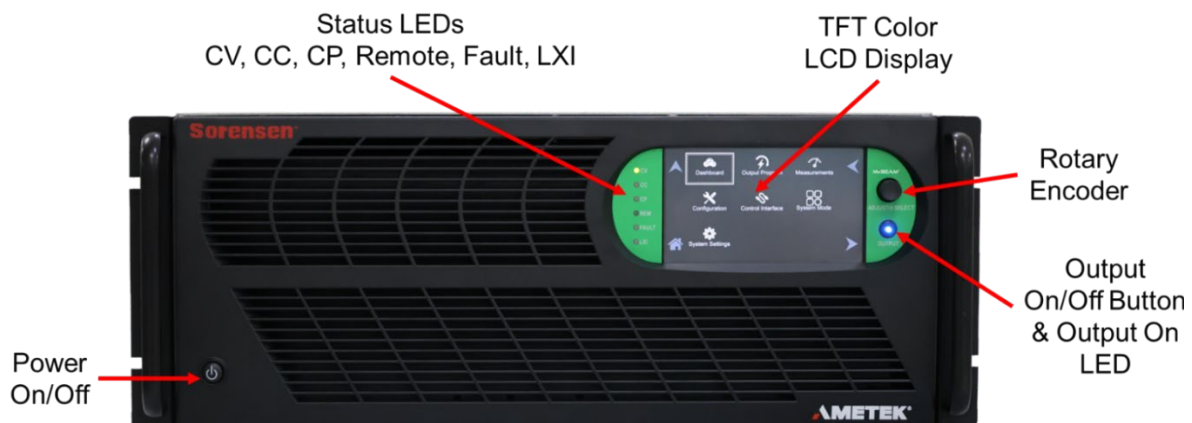

Rear Panel Connections

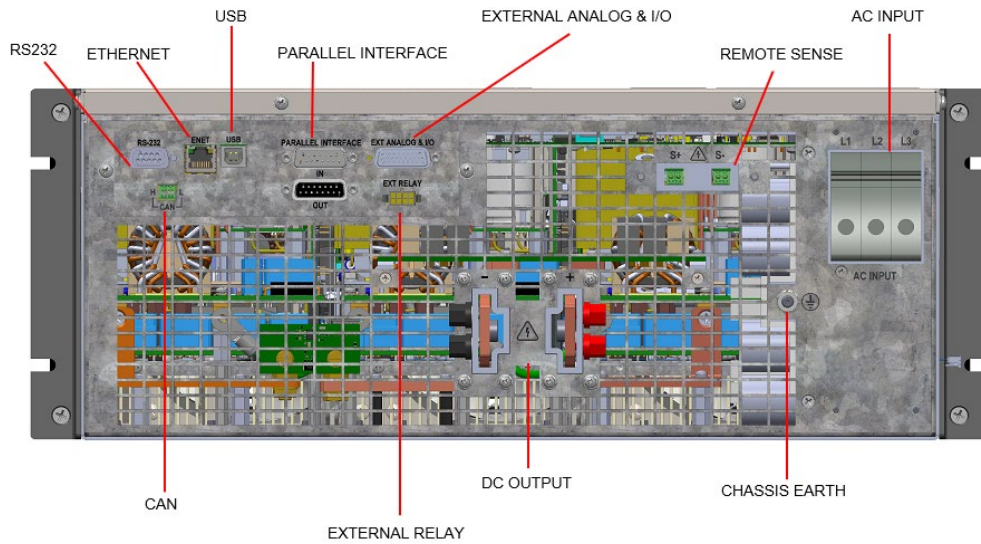

Rear Panel Connections With GPIB Option

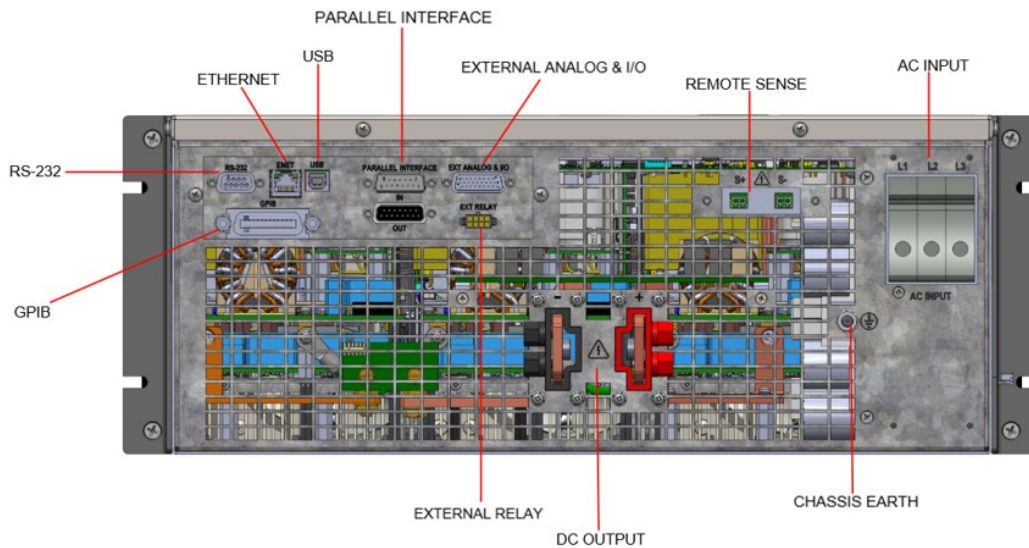

Remote Isolated External User Control I/O Signal Interface And Isolated analog interface Characteristics

FUNCTION	CHARACTERISTICS
<p>Remote Inhibit Input – Contact Closure – Open</p>	<p>Opening the Switch or Relay contact between this terminal and signal return will turn OFF the output. Switch or Relay closure or direct short from this terminal to signal return would turn-on the output.</p> <p>Remote inhibit can be configured in three modes;</p> <p>Latch: after reclosing the contact, user needs to clear the fault and turn ON the output.</p> <p>Live: after reclosing the contact, user can turn ON the output.</p> <p>OFF: inhibit function would be disabled.</p>

FUNCTION	CHARACTERISTICS
	<p>Remote circuit must sink up to 10 milliamperes (mA) from 5 volts direct current (VDC) to enable.</p>
<p>Remote Inhibit Input – Contact Closure – Close</p>	<p>Closing the Switch or Relay contact between this terminal and signal return will turn OFF the output. Switch or Relay opening would turn ON the output.</p> <p>Remote inhibit can be configured in three modes;</p> <p>Latch: after reclosing the contact, user can clear the fault and turn ON the output.</p> <p>Live: after reclosing the contact, user needs to turn ON the output.</p> <p>OFF: inhibit function would be disabled.</p> <p>Remote circuit must sink up to 10 mA from 5 VDC to enable.</p>
<p>Remote Inhibit Input – Active Source – High</p>	<p>An active voltage source high signal from this terminal to signal return will Turn OFF the output of power supply.</p> <p>Remote inhibit can be configured in three modes;</p> <p>Latch: after removing the active voltage source, user can clear the fault and turn ON the output.</p> <p>Live: after removing the active voltage source, user can turn ON the output.</p> <p>OFF: inhibit function would be disabled.</p> <p>Remote circuit must sink up to 10 mA from 5 VDC to enable.</p>
<p>Remote Inhibit Input – Active Source – Low</p>	<p>An active voltage source low signal from this terminal to signal return will Turn OFF the output of power supply.</p> <p>Remote inhibit can be configured in three modes;</p> <p>Latch: after removing the active voltage source low signal, user needs to clear the fault and turn ON the output.</p> <p>Live: after removing the active voltage source, user can turn ON the output.</p> <p>OFF: inhibit function would be disabled.</p> <p>Remote circuit must sink up to 10 mA from 5 VDC to enable.</p>
<p>Trigger In ⁽²⁾</p>	<p>TTL compatible Input signal, active-high pulse of 100 μs; detects external hardware trigger at falling edge of the pulse for voltage, current ramp and Transient List functions. Signal connects to Open-anode of opto-isolator diode with internal 1 kΩ series resistor internal to power supply.</p> <p>Voltage Rating: Maximum 24 V, Minimum -5 V</p> <p>Low state: 0.3 V max, High State 2.7 V min</p>
<p>Trigger Out ⁽²⁾</p>	<p>Output signal, active-high; synchronization pulse of 100 μs.</p> <p>Open collector transistor output, Collector is connected the 26-pin connector. Emitter point of transistor is connected to common return pin of the interface connector.</p> <p>Voltage Rating: Maximum 30 V, Minimum 3 V for Active High, Current Sink Current: 50 mA</p>

FUNCTION	CHARACTERISTICS
CC/CV Status Output	<p>Output signal, High state indicates Constant Current mode operation, and Low state indicates Constant Voltage mode operation.</p> <p>Open collector transistor output, Collector is connected the 26-pin connector. Emitter point of transistor is connected to common return pin of the interface connector.</p> <p>Voltage Rating: Maximum 30 V, Minimum 3 V for Active High, Current Sink Current: 50 mA</p>
Output ON/OFF Status	<p>Output signal, High state indicates Output is ON and Low state indicates Output is OFF</p> <p>Open collector transistor output, Collector is connected the 26-pin connector. The emitter point of transistor is connected to the common return pin of the interface connector.</p> <p>Voltage Rating: Maximum 30 V, Minimum 3 V for Active High, Sink Current: 50 mA</p>
FAULT Status	<p>Output Signal, High state indicates fault state of the power supply.</p> <p>Open collector transistor output, Collector is connected the 26-pin connector. The emitter point of transistor is connected to the common return pin of the interface connector.</p> <p>Voltage Rating: Maximum 30 V, Minimum 3 V for Active High, Current Sink Current: 50 mA</p>
ISOLATED ANALOG PROGRAMMING FEATURES	
Remote Analog Programming of Output Voltage ⁽¹⁾⁽³⁾	<p>Independent Signal inputs for output voltage programming using External Analog Reference.</p> <p>Analog reference source is user selectable and can be a voltage or resistance. Selected analog reference source can be used to program output voltage.</p> <p>Voltage as Reference Source: 0 V to user selectable maximum range (5 V to 10 V) for 0 to full scale rated Output.</p> <p>Resistance as Reference Source: 0 Ω to user selectable maximum range (5 kΩ to 10 kΩ) for 0 to full scale rated Output.</p> <p>Programming accuracy and linearity: $\pm 1\%$ of rated output</p>
Remote Analog Programming of Output Current ⁽¹⁾⁽³⁾	<p>Independent Signal inputs for output current programming using External Analog Reference.</p> <p>Analog reference source is user selectable and can be a voltage or resistance. Selected analog reference source can be used to program output current.</p> <p>Voltage as Reference Source: User selectable range of (-5 V to +5 V) or (-10 V to +10 V) for 0 to full scale rated Output.</p> <p>Resistance as Reference Source: 0 Ω to user selectable maximum range (5 kΩ to 10 kΩ) for 0 to full scale rated Output. This is applicable in source mode only.</p>

FUNCTION	CHARACTERISTICS
	Programming accuracy and linearity: $\pm 1\%$ of rated output
Monitor Signals for the Output Voltage and Output Current	Monitor Signals for the Output Voltage and Current. Full Scale range: 0 V to 10 V corresponds to 0-100% full-scale output. Minimum recommended Load: 100 k Ω , typical Maximum Load: 20 k Ω Monitor accuracy and linearity: $\pm 1\%$ of full-scale output
Remote Analog Programming of Overvoltage ⁽¹⁾⁽³⁾	Signal input for setting Overvoltage using External Analog Reference Voltage. Range: 0.25 – 0.5 V to user selectable maximum range (5 V to 10 V) for 5% to 100% of the full-scale OVP (where full-scale OVP = 110% of the full-scale output voltage). Programming accuracy and linearity: $\pm 1\%$ of full-scale output
<p>(1) Unit can be operated in remote analog programming in Bi-directional, Source and eload modes only.</p> <p>(2) Trigger IN and Trigger OUT signals can be used during Ramp and Transient List functionality only.</p> <p>(3) Analog Programming is not supported in series operation.</p>	

Remote Control Digital Interface Characteristics

INTERFACE	CHARACTERISTIC
LAN	Ethernet LXI Complaint 10BASE-T and 100BASE-T over twisted-pair cables compliant with IEEE 802.3; Connector: 8P8C modular jack.
USB	Serial interface compliant to USB 2.0; Connector: Type-B receptacle.
RS-232C	Serial interface compliant to RS-232C; Protocol: data bits, 7 with parity and 8 without parity; stop bits, 2; baud rate, 9600 to 115200; handshake, CTS and RTS; Connector: Subminiature-D, 9-contact receptacle.
CAN	Protocols: CAN2.0B and CANopen; Baud Rates: 20kbps to 1mbps (20k, 40k, 50k, 80k, 100k, 125k, 150k, 200k, 250k, 400k, 500k, 1000 kbps) ; Node Id: 1 to 127; Termination: 120 Ω recommended (termination needs to be done by the user). safety isolation SELV-rated, referenced to chassis. Unit side connector: compression terminals, Phoenix P/N 1995499 Mating Connector , Phoenix P/N 1840366 CAN 2.0B: Frame types supported: Extended frame (29-bit ID) and Data frames (DLC up to 8 bytes); Supported services: Raw CAN messages (without protocol encapsulation); Communication type: Signal Mapping via DBC; CAN database file: .dbc file support.

INTERFACE	CHARACTERISTIC
	CANopen: Frame types supported: NMT, SDO, PDO, and Heartbeat; Supported services: Object Dictionary Access; Communication type: Structured Communication via Object Dictionary and Signal Mapping via DBC; CAN database file: .dbc file support.
IEEE-488 (Optional)	Parallel interface complies with IEEE-488.1, IEEE-488.2, and the SCPI command specification; Command execution response time, 10 ms, typical; Connector: IEEE-488.1 compliant.
Firmware Upgrade	Firmware could be upgraded through the LAN interface and a Command Line Firmware Update Tool.

Protection Function Characteristics

FUNCTION	CHARACTERISTICS
Output Overvoltage Protection (OVP)	Programmable to 110% of full-scale output voltage; exceeding OVP threshold results in shutdown of output.
Output Positive Overcurrent Protection (+ve OCP) ⁽¹⁾	Programmable to 120% of full-scale output Positive current; exceeding Positive OCP threshold results in shutdown of output.
Output Negative Overcurrent Protection (-ve OCP) ⁽²⁾	Programmable to 120% of full-scale output Negative current; exceeding Negative OCP threshold results in shutdown of output.
Output Current Limit Protection	User-selectable regulation settings, Bi-DIR Mode: Voltage (programming type) – CV, CV/CC, CV-SER-RES, CV/CP Current (programming type) – CC, CC/CV, CC/CP, CP/CC. Source Mode : Voltage (programming type) – CV, CV/CC, CV/CP, CP/CV, CV-SER-RES Current (programming type) – CC, CC/CV, CC/CP, CP/CC eLoad Mode: Voltage (programming type) – CV, CV/CC, CR/CV, CP/CV, CV/CP Current (programming type) – CC, CC/CV, CR/CC, CP/CC, CC/CP In CV/CC mode, regulates voltage, on reaching the current limit power supply regulates the limit reached, on reaching the power limit results in shutdown of output. In CV/CP mode, regulates voltage, on reaching the power limit power supply regulates the limit reached, on reaching the current limit results in shutdown of output. In CC/CV mode, regulates current, on reaching the voltage limit power supply

FUNCTION	CHARACTERISTICS
	<p>regulates the limit reached, on reaching the power limit results in shutdown of output.</p> <p>In CC/CP mode, regulates current, on reaching the power limit power supply regulates the limit reached, on reaching the voltage limit results in shutdown of output.</p> <p>In CP/CC mode, regulates power, on reaching the current limit power supply regulates the limit reached, on reaching the voltage limit results in shutdown of output.</p> <p>In CP/CV mode, regulates power, on reaching the voltage limit power supply regulates the limit reached, on reaching the current limit results in shutdown of output.</p> <p>In CR/CC mode, regulates resistance, on reaching the current limit power supply regulates the limit reached, on reaching the voltage & power limit results in shutdown of output.</p> <p>In CR/CV mode, regulates resistance, on reaching the voltage limit power supply regulates the limit reached, on reaching the current & power limit results in shutdown of output.</p> <p>In CV mode, regulates voltage, on reaching current or power limits results in shutdown of output.</p> <p>In CC mode, regulates voltage, on reaching voltage or power limits results in shutdown of output.</p> <p>In CV-SER-RES mode, regulates voltage, on reaching voltage or current or power limits results in shutdown of output.</p> <p>In all the regulation settings, shutdown delay on reaching the limit is programmable from 100 ms to 5 s</p>
AC Input Overcurrent Protection	Internal fuses in each phase for fault isolation; not user replaceable
AC Input Undervoltage Protection	Automatic shutdown for insufficient AC input voltage
Islanding Detection	In sink mode, the loss of input AC grid is detected by built-in islanding detection feature. Thus, accidental islanding formation with the regenerative load is avoided.
AC Input Transient Protection	Protection to withstand EN61326-1, Surge testing to industrial test levels
Overtemperature Protection (OTP)	Internal temperature monitors cause shutdown of output if temperature thresholds are exceeded
<p>(1) This is applicable in Bi-Directional, Source, PV Simulator, Battery Simulator and Battery Test operating modes.</p> <p>(2) This is applicable in Bi-Directional, e-load, Battery Simulator and Battery Test operating modes.</p>	

Output Isolation

PARAMETER	ISOLATION
	600 V < Output Voltage ≤ 2000 V
Output terminal Chassis Earth ⁽¹⁾	1428 V _{RMS} / ±2000 V _{peak}
Output terminal Positive to (+Ve) to Negative (-Ve)	V _{peak} = 110% of output rated voltage
Isolated Analog interface Signals and External User Control I/O interface to Output Negative terminal ⁽²⁾	±2000 V _{peak} , maximum
Input AC to Output DC, working voltage ⁽³⁾	1460 V _{RMS} / ±2045 V _{peak}
<p>(1) The output terminal positive to chassis earth voltage is the sum of the output terminal negative to chassis earth voltage and operating output voltage. At any operating condition, the output terminals to chassis earth voltage should not exceed the given limit.</p> <p>(2) The Isolated Analog programming and external user interface signals are galvanically isolated from negative output terminal; operation of Isolated Analog Interface signals should be at SELV safety voltage conditions to chassis ground.</p> <p>(3) Input AC and Output DC are galvanically isolated.</p>	

Environmental Specifications

PARAMETER	SPECIFICATION
Operating Temperature	0°C to +40°C (+32°F to +104°F)
Storage Temperature	-25°C to 65°C (-13°F to +149°F)
Altitude	2000 m (6,600 ft)
Operating Humidity	20-80 %, non-condensing
Relative Humidity	10-95 %, non-condensing
Vibration	MIL-PRF-28800F, Class 3; 5-500 Hz per Paragraph 4.5.5.3.1. MIL-PRF-28800F, Class 3; 5-55 Hz per Paragraph 4.5.5.3.2.
Shock	MIL-PRF-28800F, Class 3; 20G half-sine with 11 ms duration per Paragraph 4.5.5.4.1.
Transportation Integrity	ISTA Test Procedure 1B

Regulatory Agency Compliance

PARAMETER	SPECIFICATION
EMC	CE marked for EMC Directive 2014/30/EU per EN61326-1:2021, Class-A for emissions and immunity as required.
Safety	NRTL marked for US and Canada to CAN/CSA-C22.2 No. 61010-1-12, UL 61010-1 Third Edition. CE marked for LVD compliance 2014/35/EU to EN 61010-1 Third Edition as required for the EU CE mark.
CE Mark LVD Categories	Installation Overvoltage Category: II; Pollution Degree: 2, IP20 Indoor use only.
RoHS	CE marked for compliance with RoHS3 EU Directive 2015/863/EU for Restriction of Hazardous Substances in Electrical and Electronic Equipment.

Mechanical Specifications

PARAMETER	SPECIFICATION
Dimensions	H, 6.97" (177 mm); W (front panel), 18.9" (480 mm); D, 27.56" (700 mm-enclosure only); H, 6.97" (177 mm); W (Chassis), 16.9" (429 mm); D, 27.56" (700 mm- enclosure only);
Unit Weight	37.5kW: 600V, 1500V, 2000V models – 62kgs (136.69 lbs) 25kW: 1500V, 2000V models – 62kgs (136.69 lbs) 25kW: 600V model – 50kgs (110.23 lbs) 12.5kW: 600V model – 38kgs (83.78 lbs).
Shipping Weight	37.5kW: 600V, 1500V, 2000V models – 90kgs (198.42 lbs) 25kW: 1500V, 2000V models – 90kgs (198.42 lbs) 25kW: 600V model – 78kgs (171.96 lbs) 12.5kW: 600V model – 66kgs (145.50 lbs).
Chassis Material	Steel with plastic front panel
Chassis Finish	Steel electroplated
Installation	Protective covers are provided for AC input and DC output; Rackmount: per ANSI-EIA-310-D, with front panel mounting flanges and chassis provisions for mounting rack slides; slides option available.
Cooling	Force-air cooling; linear, variable fan speed control; air intake at front/sides and exhaust at rear.
Acoustic Noise	56 dBA, at idle fan speed; measured at 1.5 m with A-weighting; 78 dBA, at maximum fan speed; measured at 1.5 m with A-weighting;

Output Isolation Chassis

Mi-BEAM Series power supply when interfaced with the Mi-BEAM Output Isolation Chassis provides output isolation and negative voltage polarity detection.

Mi-BEAM Output Isolation Chassis must be purchased separately along with the interfacing cable.

The items required for output isolation and negative voltage polarity detection are,

- Mi-BEAM Isolation Chassis (5580714-01R – rated for 2000 V and 1000 A)
- Cable Assembly (5580715-01R)

Refer to the Operation Manual (P/N: M587351-01) for more information.

Part Number Scheme

Voltage	Power	Current
600V	12kW	50A
600V	25kW	100A
600V	37kW	150A
1500V	25kW	50A
1500V	37kW	50A
2000V	25kW	50A
2000V	37kW	50A

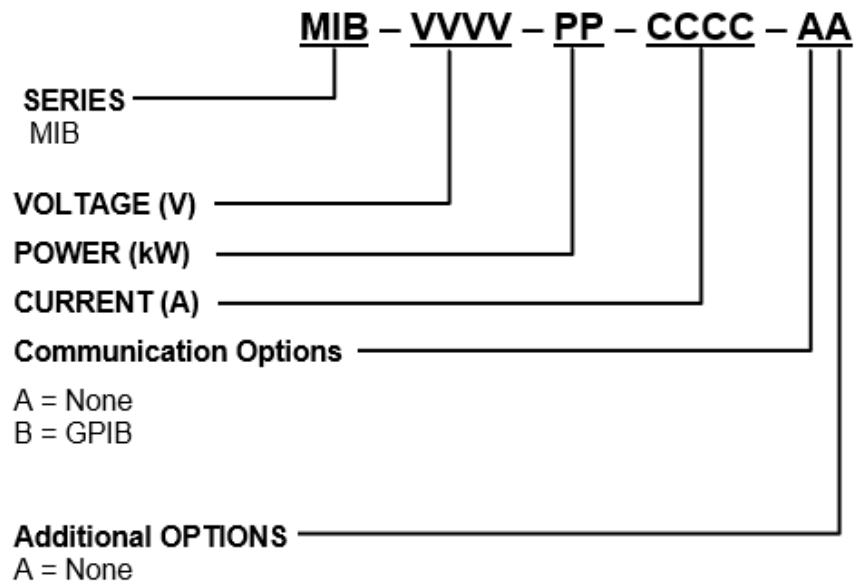

NOTE: The Mi-BEAM has a Universal 3-Phase AC Input to accept 200 to 480VAC (Range 180 to 528VAC).

AC Input Voltages of 200VAC to 240VAC (Range 180 to 264VAC) will derate the output power 50%.

- 12kW reduced to 6kW
- 25kW reduced to 12kW
- 37kW reduced to 18kW

Model Number Example:

MIB-2000-37-0050-AA = Mi-BEAM, 2000V output, 37.5kW, 50A Output, No Options

MIB-0600-25-0100-AA = Mi-BEAM, 600V output, 25kW, 100A Output, No Options

MIB-0600-12-0050-AA = Mi-BEAM, 600V output, 12.5kW, 50A Output, No Options.

Warranty Statement:

AMETEK Programmable Power Inc. warrants its products to be free from defects in material and workmanship. The warranty period is from the date of original shipment of the product to the original purchaser (see website for warranty periods by product). The Mi-BEAM Series comes with a **Five (5)** year warranty.

NOTE: All specifications subject to change without notice.