



***R Option, S Option
DC Power Supplies***

**IEEE 488.2/RS-232
Programming Manual**

Power Ten
9250 Brown Deer Road
San Diego, CA 92121-2294
1-800-733-5427
Tel: (858) 450-0085
Fax: (858) 458-0267
Email: sales@elgar.com
www.elgar.com

©2002 by Power Ten. This document contains information proprietary to Power Ten. The information contained herein is not to be duplicated or transferred in any manner without prior written permission from Power Ten.

June 25, 2002

Document No. M550013-01 Rev C

CONTENTS

SECTION 1	FEATURES, FUNCTIONS, AND SPECIFICATIONS	1-1
1.1	Introduction.....	1-1
1.2	Features and Functions.....	1-1
1.3	Specifications.....	1-2
SECTION 2	CONFIGURATION.....	2-1
2.1	Setup Procedure.....	2-1
2.2	Rear Panel Configuration Switch.....	2-2
2.2.1	Remote/Local Selection.....	2-3
2.2.2	Power-On GPIB Service Request (PON SRQ) Selection.....	2-4
2.2.3	Master/Slave Selection.....	2-4
2.2.4	Address Selection.....	2-4
2.3	Remote Programming Via RS-232	2-5
2.4	Extended Interface Bus (EIB) with S Option.....	2-6
SECTION 3	IEEE 488.2 AND SCPI COMMAND OPERATION	3-1
3.1	Introduction.....	3-1
3.2	IEEE-488.2 Register Definitions	3-1
3.2.1	SCPI Status Byte	3-1
3.2.2	Standard Event Status Register (ESR).....	3-2
3.2.3	Protection Condition and Protection Event Status Register	3-3
3.2.4	Operation Status and Questionable Status Registers	3-3
3.2.5	Error/Event Queue.....	3-3
3.2.6	Serial Poll Operation.....	3-6
3.3	IEEE-488.2 and SCPI Conformance Information	3-6
3.3.1	Parameter Definitions	3-6
3.3.2	Units.....	3-7

3.3.3	Conventions	3-7
3.3.4	Queries.....	3-7
3.4	IEEE-488.2 Common Command Subsystem.....	3-8
3.5	CALIBRATION SCPI Command Subsystem.....	3-10
3.5.1	CALIBRATION SCPI Command Summary	3-10
3.5.2	CALIBRATION SCPI Command Reference.....	3-11
3.6	MEASURE SCPI Command Subsystem.....	3-13
3.6.1	MEASURE SCPI Command Summary	3-13
3.6.2	MEASURE SCPI Command Reference.....	3-13
3.7	OUTPUT SCPI Command Subsystem.....	3-14
3.7.1	OUTPUT SCPI Command Summary	3-14
3.7.2	OUTPUT SCPI Command Reference.....	3-14
3.8	SOURCE SCPI Command Subsystem	3-15
3.8.1	SOURCE SCPI Command Summary.....	3-15
3.8.2	SOURCE SCPI Command Reference	3-16
3.9	STATUS SCPI Command Subsystem	3-20
3.9.1	STATUS SCPI Command Summary.....	3-20
3.9.2	STATUS SCPI Command Reference.....	3-20
3.10	SYSTEM SCPI Command Subsystem.....	3-22
3.10.1	SYSTEM SCPI Command Summary	3-22
3.10.2	SYSTEM SCPI Command Reference.....	3-22
3.11	TRIGGER SCPI Command Subsystem	3-24
3.11.1	TRIGGER SCPI Command Summary.....	3-24
3.11.2	TRIGGER SCPI Command Reference	3-24
3.12	Examples of Using the SCPI Commands	3-25
SECTION 4 CALIBRATION		4-1
4.1	Introduction	4-1
4.2	Setup for Calibration	4-2
4.3	Voltage Programming Calibration	4-3
4.4	Voltage Measurement/Readback Calibration.....	4-4
4.5	Overvoltage Protection Programming Calibration.....	4-5
4.6	Current Programming Calibration	4-6
4.7	Current Measurement/Readback Calibration.....	4-7
4.8	Voltage Programming and Readback Calibration	4-8
4.9	Current Programming and Readback Calibration	4-9
SECTION 5 OPERATION WITH THE S OPTION		5-1
5.1	Introduction	5-1

5.2	Configuration	5-1
5.3	System Installation.....	5-3
5.4	RS-485 Interface.....	5-3
5.5	Programming the S Option (Example).....	5-4

LIST OF FIGURES

Figure 2–1	Configuration Switch, R60 Series and R80 Series.....	2-2
Figure 2–2	Configuration Switch, R31 Series.....	2-2
Figure 2–3	RS-232 Rear Panel RJ-11 Connector Pinout.....	2-5
Figure 2–4	R Option–to–PC RS-232 Connection (RJ-11 to DB-9).....	2-5
Figure 2–5	RS485 Rear Panel RJ-11 Connector Pinout	2-6
Figure 2–6	R Option–to–S Option EIB Connection (RJ-11 to RJ-11).....	2-6
Figure 5–1	S Option–Channel 2 in Remote Mode, S60 Series and S80 Series	5-1
Figure 5–2	S Option–Channel 2 in Remote Mode, S31 Series	5-2
Figure 5–3	RS-485 System Interconnection with Two Slaves (S Options)	5-3
Figure 5–4	S Option Rear Panel RS-485 Connectors Pinout.....	5-3

LIST OF TABLES

Table 5–1	Definitions of S1 Switch Settings.....	5-2
-----------	--	-----

SECTION 1

FEATURES, FUNCTIONS, AND SPECIFICATIONS

1.1 Introduction

The R Option interface card enables you to operate your Power Ten power supplies from a computer via the IEEE-488.2 GPIB or RS-232 interface, allowing full remote programming control and monitoring of your power supply. The R Option is compatible with SCPI languages. Multiple source control is supported by the R Option allowing control of up to 30 Slave (S Option) power supplies with the Extended Interface Bus.

1.2 Features and Functions

Features

- 12-bit programming and 12-bit readback of voltage and current
- Programmable overvoltage protection with reset
- IEEE-488.2 and SCPI compliant command set
- User selectable Constant-Voltage/Constant-Current or Foldback mode, with reset
- Voltage Ramp and Current Ramp functions
- Field-upgradable firmware via RS-232
- Attachment of up to 30 supplies via EIB interface with the S Option
- Soft calibration
- Rear panel IEEE-488.2 and RS-232 control interface
- Rear panel configuration switch

Programmable Functions

- Output voltage and current
- Soft limits for voltage and current
- Overvoltage protection
- Output enable/disable
- Maskable fault interrupt
- Hold and trigger
- External relay control
- Full calibration

Readback Functions

- Actual measured voltage and current
- Voltage and current settings
- Soft voltage and current limits
- Overvoltage protection setting
- Status and Accumulated Status registers
- Programming error codes
- Fault codes
- Manufacturer, power supply model, and firmware version identification

1.3 Specifications

(SUBJECT TO CHANGE WITHOUT NOTICE)

Programming Resolution

Voltage: 0.03% of full scale

Current: 0.03% of full scale

Overvoltage Protection: 0.03% of full scale (full scale is 110% of max output voltage.)

Programming Accuracy

Voltage: $\pm (0.1\% + 0.1\%$ of maximum output voltage)

Current: $\pm (0.1\% + 0.4\%$ of maximum output current)*

Overvoltage Protection: $\pm (0.5\% + 0.5\%$ of max output voltage)

Readback Resolution

Voltage: $\pm 0.03\%$ of full scale

Current: $\pm 0.03\%$ of full scale

Readback Accuracy

Voltage: $\pm (0.1\% + 0.15\%$ of full scale output voltage)

Current: $\pm (0.1\% + 0.4\%$ of full scale output current)*

* After 30 minutes operation with fixed line, load, and temperature.

Note: Refer to the power supply manual for effects of line regulation, load regulation, and temperature on accuracy specifications.

SECTION 2 CONFIGURATION

The R Option is installed into the supply at the factory. Use the Setup Procedure described below to configure the R Option for your system and application.

2.1 Setup Procedure

This procedure is a quick reference for the configuration requirements. Refer to Section 2.2 for detailed information on the rear panel switches.

1. Set the rear panel switch S1-1 to ON to set unit to remote mode.
2. Set the rear panel switch S1-2 to OFF to set the unit to no SRQ upon power-on..
3. Use the rear panel switches S1-4 to S1-8 to set the primary address. Select a unique primary address to identify the power supply to the computer controller in your system
4. Connect the IEEE-488.2 or RS232 bus to the supply.
5. Connect power to the unit and turn on the unit.
6. Configure the controller to match the supply identification and configuration. Use one of the available programs such as IBCONF from National Instruments for GPIB, or set the RS232 baud rate to 19200, 8 data bits, no parity, and 1 stop bit.
7. Test the communication interface by issuing a *IDN? Command. This returns the supply's model and firmware versions and does not affect the output of the supply.

2.2 Rear Panel Configuration Switch

The DIP switch S1 is accessible from the rear panel to allow configuration of the supply for the user's particular system and application.

Figure 2-1 shows the switch settings for a supply with the installed R Option.

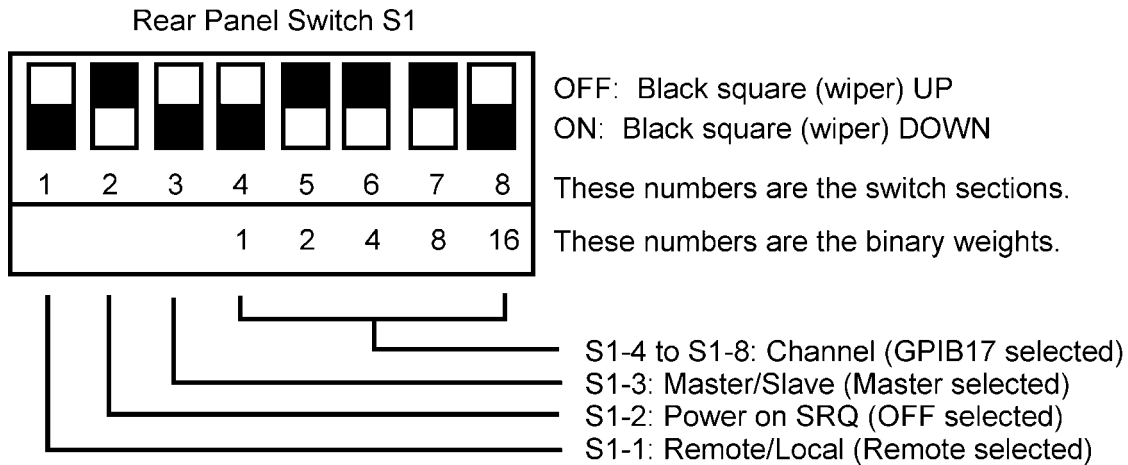

Figure 2-1 Configuration Switch, R60 Series and R80 Series

Figure 2-2 shows the switch settings for an R3100 Series supply.

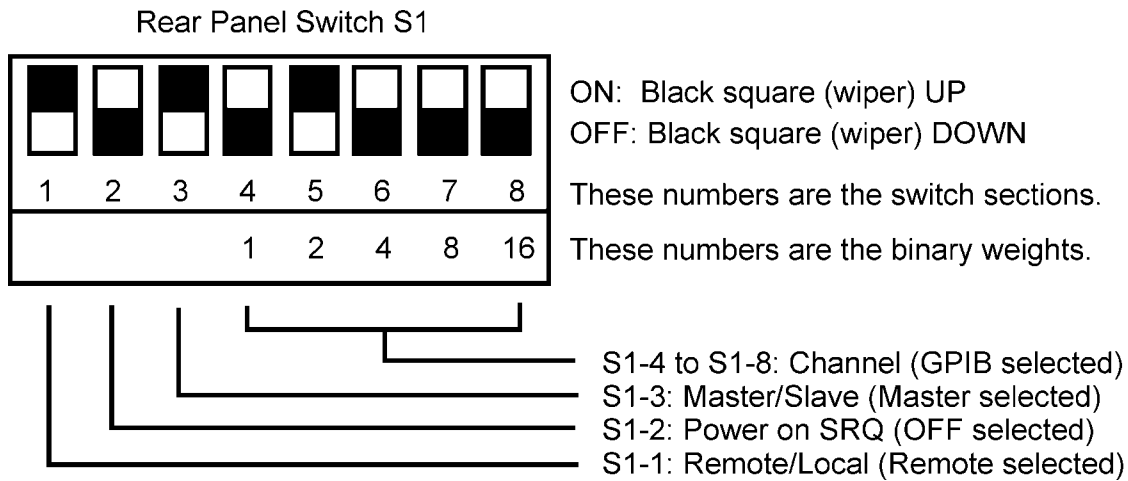

Figure 2-2 Configuration Switch, R31 Series

2.2.1 Remote/Local Selection

Set the rear panel Remote/Local switch to select remote or local operation.

REMOTE/LOCAL SWITCH

Switch Position	Description
ON	Remote operation selected. Front panel control is disabled. Control is accessible only through GPIB or RS-232.
OFF	Local operation selected. Front panel control is enabled. Unit will switch to remote operation at the first GPIB or RS-232 command.

Powering up in remote mode will result in the following operating conditions.

REMOTE MODE POWER-ON CONDITIONS

Condition	Default
Voltage	0 Volts (initial power-on voltage). Also see CAL:INIT:VOLT
Current	0 Amps (initial power-on current). Also see CAL:INIT:CURR
Soft Voltage Limit	Model maximum voltage
Soft Current Limit	Model maximum current
OVP Trip Voltage	Model maximum voltage +10% (initial power-on OVP).
Delay	0.5 seconds
Foldback Protection	OFF
Output	ON
Hold	OFF
Unmask	NONE
Service Request Capability	OFF

2.2.2 Power-On GPIB Service Request (PON SRQ) Selection

Set the rear panel PON SRQ switch S1-2 to ON to cause a GPIB service request to be sent to the computer controller when the supply is turned on. The front panel SRQ LED will also turn on. You may clear the service request and turn off the SRQ LED by issuing a serial poll.

POWER-ON GPIB SERVICE REQUEST (PON SRQ) SWITCH S1-2

Switch Position	Description
ON	Power-On SRQ selected
OFF	No Power-On SRQ selected

Refer to your specific GPIB controller card manual for further details on serial polling.

2.2.3 Master/Slave Selection

For the R Option, set the rear panel Master/Slave switch S1-3 to ON to configure the supply to be the Master. The address selection for a master is the GPIB address (1-30). For the S Option, set the Master/Slave switch S1-3 to OFF to configure the supply to be a Slave unit. The address selection for a slave unit is the channel number of that device (2-31). Refer to Section 2.2.4 for more details regarding address selection.

MASTER/SLAVE SWITCH S1-3

Switch Position	Description
ON	Master unit (R Option only)
OFF	Slave unit (S Option only)

2.2.4 Address Selection

The address selection is binary with switch S1-4 as the LSB and S1-8 as the MSB. The rear panel switch illustration in Section 2.2 shows the address selection 00101 in binary (5 decimal).

The address selection for a master unit is the GPIB address of that device (1-30). The address selection for a slave unit is the channel number of that device (2-31). Channel selections 0 and 1 are invalid for a slave device because SCPI reserves channel 0 as the global channel to address all channels and channel 1 as the default master channel to address the master unit.

ADDRESS SWITCHES S1-4 to S1-8

Switch Position	Description
ON	1
OFF	0

2.3 Remote Programming Via RS-232

The R Option's RS-232 interface operates at 19.2Kbaud with 8 data bits, no parity, and 1 stop bit. All R Option commands are supported at the RS-232 interface with the exception of the Service Request (SRQ) function, which is a GPIB-specific function requiring the dedicated Service Request line of the IEEE-488.2 interface. In this case, the SRQ function has no effect. The RS-232 interface is accessible through the rear panel 6-pin RJ-11 connector J1.

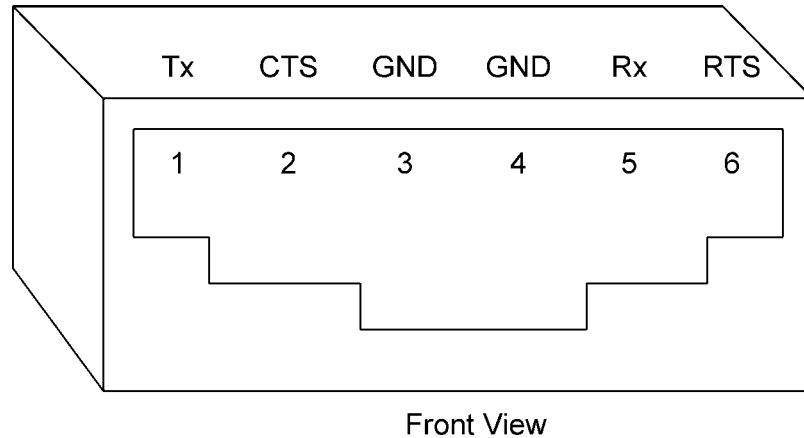

Figure 2-3 RS-232 Rear Panel RJ-11 Connector Pinout

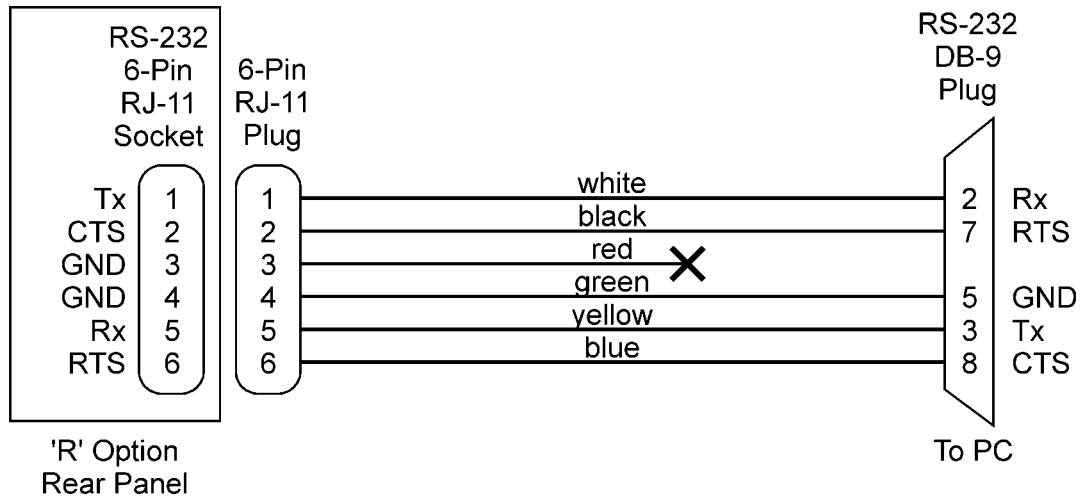

Figure 2-4 R Option-to-PC RS-232 Connection (RJ-11 to DB-9)

2.4 Extended Interface Bus (EIB) with S Option

The S Option is a slave controller used in conjunction with the R Option to provide multiple sources controlled by a single GPIB address or via a single RS-232 connection. Up to 30 EIB controllers can be attached to a single R Option via the EIB(RS-485) bus connection at the rear panel of the R Option. The EIB is accessible through the rear panel 6-pin RJ-11 connector J2.

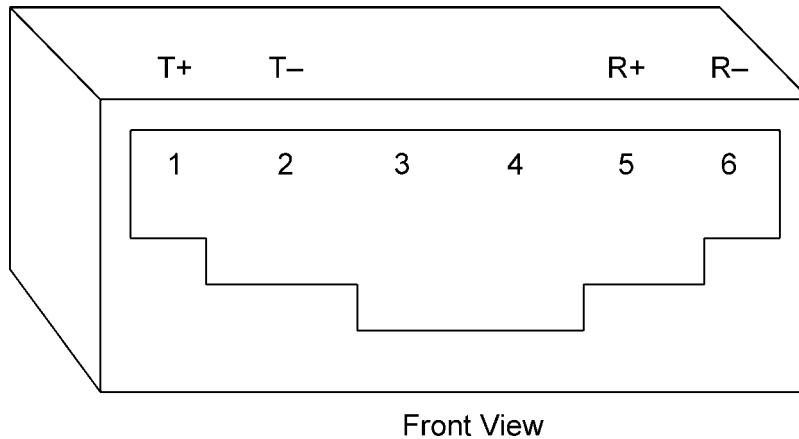

Figure 2-5 RS485 Rear Panel RJ-11 Connector Pinout

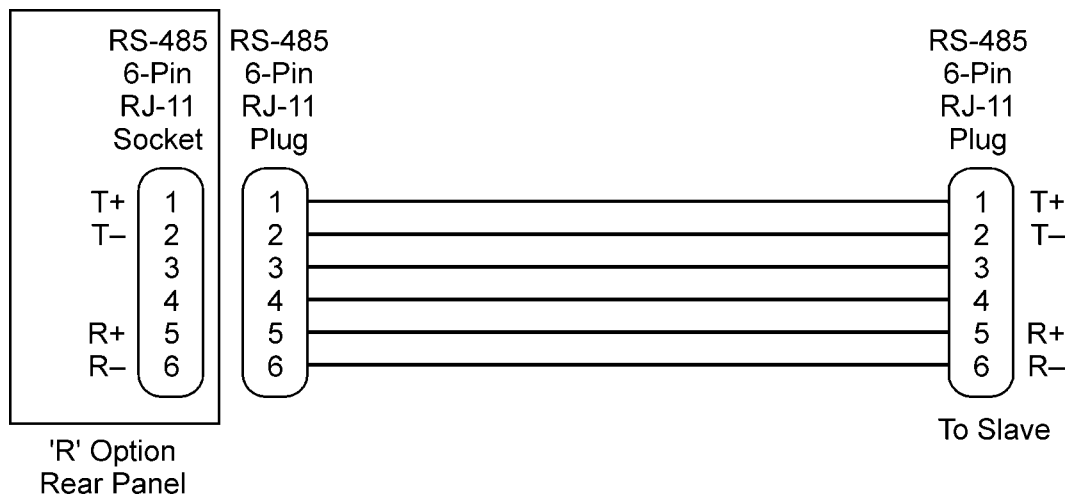

Figure 2-6 R Option-to-S Option EIB Connection (RJ-11 to RJ-11)

SECTION 3

IEEE 488.2 AND SCPI COMMAND OPERATION

3.1 Introduction

The following sections describe the operation of the R Option by remote programming using the IEEE-488.2 and SCPI command sets. These command sets provide programming, query, and status commands that facilitate remote control of the power supply.

3.2 IEEE-488.2 Register Definitions

The R Option supports the IEEE-488.2 and SCPI 1995.0 status reporting data structures. These structures are comprised of status registers and status register enable mask pairs. The following sections describe these pairs.

3.2.1 SCPI Status Byte

The SCPI Status Byte status register can be read by the *STB? command or by issuing a GPIB serial poll. The Status Byte status register can be cleared by the use of the *CLS command.

The R Option can be configured to request service from the GPIB controller by setting the appropriate bits in the Service Request Enable Register (SRE). The SRE register has the same bit pattern as the Status Byte. It is modified using the *SRE <mask> command and read with the *SRE? command. For example, if the SRE register is set to 0x10 (MAV), when the R Option unit has a message available, the Status Byte register will contain 0x50 (RQS and MAV) and the SRQ line of the GPIB will be asserted to indicate a request for service. See table below for further information.

SCPI STATUS BYTE

Bit	Hex Value	Description
0	0x01	Not used.
1	0x02	Protection Event Status flag. Indicates the selected protection event occurred.
2	0x04	Error/event queue message available. Set when any error/event is entered in the System Error Queue. It is read using the SYSTem:ERRor? query.
3	0x08	Questionable Status flag. Indicates the quality of the current data being acquired. This bit is not used.
4	0x10	Message available (MAV). Indicates a message is available in the GPIB output queue. Cleared after the GPIB output buffer is read.
5	0x20	Standard Event Status Register (ESR). Summary bit for the ESR. Set when any of the ESR bits are set and cleared when the ESR is read.
6	0x40	Request Service flag (RQS) for serial polling or Master Summary Status (MSS) in response to *STB?. If service requests are enabled (with the *SRE command) this bit represents the RQS and will be sent in response to a serial poll, then cleared. If RQS is not enabled, the bit represents the MSS bit and indicates the device has at least one reason to request service. Even though the device sends the MSS bit in response to a status query (*STB?), it is not sent in response to a serial poll. It is not considered part of the IEEE-488.1 Status Byte.
7	0x80	Operation Status flag. Indicates the current operational state of the unit. This bit is not used.

3.2.2 Standard Event Status Register (ESR)

The Standard Event Status Register (ESR) can be read by the *ESR? command. Reading this register or issuing a *CLS command will clear the ESR. Use the *ESE (Standard Event Status Enable Register) to enable corresponding ESR bits to be summarized in the summary bit of the SCPI Status byte. To configure the R Option to generate GPIB service requests based on the ESR, both the Standard Event Status Enable Register and the Service Request Enable Register must be programmed. See table below for further information.

STANDARD EVENT STATUS REGISTER

Bit	Hex Value	Description
0	0x01	Operation Complete
1	0x02	Request Control - not used
2	0x04	Query Error
3	0x08	Device Dependent Error
4	0x10	Execution Error (e.g., range error)
5	0x20	Command Error (e.g., syntax error)
6	0x40	User Request - not used
7	0x80	Power On

3.2.3 Protection Condition and Protection Event Status Register

These two registers have the same bit meanings, but they differ in regards to how they function.

The Protection Condition Register can be read using the STAT:PROT:COND? command. This command gives the *present status condition* of the power hardware, so the data is not latched. It is meant to be used as a polling register.

The Protection Event Status Register can be read by the STATus:PROTEction:EVENT? command. Reading this register, issuing a *CLS command, or issuing a *RST command will clear the Protection Event Status Register. Bits in the Protection Event Status Register will only be set when the corresponding bit in the Protection Event Status Enable Register is set and the corresponding event occurs. The status is then latched and will remain in that state until it is read or cleared due to some command action. (Use the STATus:PROTEction:ENABLE <mask> command to set the Enable Register and the STATus:PROTEction:ENABLE? query to read the Enable Register.) To configure the R Option to generate GPIB service requests based on the Protection Event Status Register, both the Protection Event Status Enable Register and the Service Request Enable Register (*SRE) must be programmed. Refer to the table below for further information.

PROTECTION CONDITION AND EVENT STATUS REGISTERS

Bit	Hex Value	Description
0	0x01	Constant voltage operation
1	0x02	Constant current operation
2	0x04	Not used
3	0x08	Overvoltage protection tripped
4	0x10	Overtemperature protection tripped
5	0x20	Supply external shutdown active
6	0x40	Foldback mode operation
7	0x80	Remote programming error

3.2.4 Operation Status and Questionable Status Registers

The Operation Status and Questionable Status Registers will always return 0 when queried. The Operation Status Enable and Questionable Status Enable Registers can be programmed and queried to allow SCPI compatibility but have no effect on the Operation Status and Questionable Status Registers.

3.2.5 Error/Event Queue

The R Option maintains an Error/Event Queue as defined by SCPI. The queue holds up to 10 error events. It is queried using the SYSTem:ERRor? command which reads in a First In/First Out (FIFO) manner. The read operation removes the entry from the queue. The *CLS command will clear all entries from the queue.

The following error codes are defined in the SCPI 1995.0 specification and are supported by the R Option. Error codes are in the range of [-32768, 32767]. SCPI reserves the negative error codes and 0, while error codes greater than 0 are device specific errors.

SCPI ERROR CODES

Error Code	Description
206	No channels setup to trigger This means that an attempt was made to trigger the R Option using the TRIG:TYPE <1 2 3> command when there are no armed trigger settings. This error is <i>not</i> generated when the GET is received, even when there are no armed trigger settings.
205	GPIB GET not allowed during message This error means that the GPIB G(roup) E(xecute) T(ripper) multiline command was errantly generated by the system computer while or very shortly after a message is or was sent. Give a few milliseconds after a message was sent before attempting a GET; and never send a GET during the midst of a message transfer over the GPIB.
204	GPIB IFC caused warm boot This error relates to the GPIB IFC signal, and is available only in association with a proprietary command.
203	Hardware watchdog warm boot This error is caused by a hardware fault either in the power supply, or on the R Option. A possible explanation might be that the mains power to the supply was interrupted for a short but sufficient time to cause the R Option's processor to reset and re-boot. Also, it may be possible to generate this error by a very momentary off action of the front panel power switch.
202	Foreground watchdog warm boot This error means that the internal firmware on the R Option found an internal error condition that halted processing; to force resumption of processing, a warm boot was required.
201	Unexpected warm boot This error means that the R Option GPIB-side processor experienced a warm boot that was unexpected, and it may indicate an internal crash of the R Option processor.
102	Incompatible unit type This error is not used. It cannot occur.
101	Incompatible unit version This slave does not support user defined initialization values nor ramping; its firmware is too old a version to do so. Slave #n provides its firmware version number as the last number on the response from the *IDN[n]? query command.
100	Incompatibility error This error is not used. It cannot occur.
0	No error The error queue is empty.
-102	Syntax error An unrecognized command or data type was encountered.
-108	Parameter not allowed More arguments than expected were received.
-151	Invalid string data Incorrect password. Manufacturer, model, or serial number string was more than 16 characters. Invalid mnemonic.

-161	Invalid block data The expected number of data values was not received.
-200	Execution error An error/event number in the range [-299,-200] indicates that an error has been detected by the instruments execution control block. The occurrence of any error in this class shall cause the execution error bit (bit 4) in the Event Status Register to be set. An execution error can be the result of: <ul style="list-style-type: none"> • A <program data> element out of range, such as programming 35 volts in a 33 volt device. • A command could not be executed due to the current condition of the device.
-203	Command protected Attempted to store calibration values to EEPROM without unlocking.
-221	Settings conflict Attempted to set output greater than soft limits or to set soft limits less than output.
-222	Data out of range Parameter exceeded range of valid values.
-225	Out of memory There is not enough memory to perform the requested operation.
-241	Hardware missing A legal command or query could not be executed because the option is not installed.
-284	Program currently running A legal command or query could not be executed because a function is currently running.
-292	Referenced name does not exist
-293	Referenced name already exists
-316	Checksum error
-330	Self-test failed A self-test failure has occurred.
-340	Calibration failed Error during calculation of calibration values occurred.
-350	Queue overflow The error queue can contain up to 10 entries. If more than 10 error/event conditions are logged before the SYSTem:ERRor? query, an overflow will occur; the last queue entry will be overwritten with error -350. When the queue overflows, the least recent error/events remain in the queue and the most recent error/events are discarded.
-360	Communication error Communications to a channel was disrupted.

3.2.6 Serial Poll Operation

Performing a serial poll will not modify the Status Byte other than to clear the RQS (bit 6) for an R Option requesting service. Queries affecting the Status Registers and subsequent serial poll are described below:

- *STB? clears the Status Byte
- *ESR? clears the ESR and bit 5 of the Status Register
- SYSTem:ERRor? clears bit 2 of the Status Register if the queue is empty

3.3 IEEE-488.2 and SCPI Conformance Information

The R Option conforms to most of the specifications for devices as defined in IEEE-488.2 and SCPI Version 1995.0. Confirmed Commands are those commands that are approved commands in the SCPI 1995 Specification, Volume 2: Command Reference. They are denoted by a “C” in the “SCPI” column. Any commands that are not Confirmed Commands are labeled as Not Approved denoted by an “N.”

3.3.1 Parameter Definitions

PARAMETER DEFINITIONS	
Type	Valid Arguments
<boolean>	“ON” or 1. “OFF” or 0.
<NR1>	The data format <NR1> is defined in IEEE-488.2 for integers. Zero, positive and negative integer numeric values are valid data.
<0+NR1>	Zero and positive integer numeric values.
<-NR1>	Negative integer numeric values.
<NRf>	The data format <NRf> is defined in IEEE-488.2 for flexible Numeric Representation. Zero, positive and negative floating point numeric values are some examples of valid data.
<0+NRf>	Zero and positive floating point numeric values.
<-NRf>	Negative floating point numeric values.
<string>	Characters enclosed by single or double quotes.

3.3.2 Units

The R Option will accept the following units as suffixes to numeric values:

UNITS	
Type of Unit	Valid Suffix
Voltage	"VOLTS" or "volts", "V" or "v", "MV" or "mv" or "mV"
Current	"AMPS" or "amps", "A" or "a", "MA" or "ma" or "mA"
Time	"SEC" or "sec", "S" or "s", "MS" or "ms", "MIN" or "min"
Frequency	"HZ" or "hz"

The default units are VOLTS, AMPS, SEC, and HZ. For example, "SOUR:VOLT 1" programs 1 volt. To program in units of millivolts, type "SOUR:VOLT 1mV".

3.3.3 Conventions

SCPI uses the conventions where optional commands and parameters are enclosed by "[]". Additionally the shorthand version of a command is indicated by capital letters. The optional parameter "[n]" selects the slave channel number (S Option power supply) being commanded. If "[n]" is not specified, the default master channel 1 is automatically selected. Channel 1 selects the master unit (R Option) and channels 2-31 select an attached slave unit (S Option). Selecting the global channel 0 is allowed only for the TRIGgerred[n] commands.

For example,

```
SOURce[n]:VOLTage[:LEVel][:IMMEDIATE][:AMPLitude] 120.0
```

can be written as

```
SOURce[n]:VOLTage 120.0 // for any channel
```

or

```
SOUR:VOLT 120.0 // for default master channel 1
```

3.3.4 Queries

The query syntax is identical to the command syntax with a "?" appended. For example, to query the programmed voltage, send the string: SOURce:VOLTage?. A subsequent device read will return a value such as "33.000". All queries are terminated with a carriage return and line feed (0x0D 0x0A) for those GPIB controllers that require termination characters. When the R Option has nothing to report, its output buffer will contain two ASCII characters: a carriage return and linefeed (in decimal the values are: <13><10>).

3.4 IEEE-488.2 Common Command Subsystem

The following commands are common to all SCPI instruments and declared mandatory by IEEE-488.2. In the following table, the R Option is defined as the “device” on the GPIB bus.

Command	Description
*CLS[n]	Clears all status reporting data structures including the Status Byte, Standard Event Status Register, and Error Queue. The STAT:PROT:ENAB (protection event enable register) is cleared by this command; other enable registers are not cleared by this command.
*ESE[n] <0+NR1>	Sets the value of the Standard Event Status Enable Register that determines which bits can be set in the Standard Event Status Register. See section 3.2.2 for valid values.
*ESE[n]?	Returns the integer value of the Standard Event Status Enable Register. See section 3.2.2 for valid values. Response: <0+NR1>
*ESR[n]?	Returns the integer value of the Standard Event Status Register. The ESR and the Status Byte ESR bit are cleared. See section 3.2.2 for valid values. Response: <0+NR1>
*IDN[n]?	Returns the device identification as an ASCII string. Response: <Manufacturer>, <model>, <serial number>, <DCI firmware version>, <AI firmware version> Example: Power Ten, R83C-10050, 0203A00010, 1.0, 1.0
*OPC[n]	Enables the Operation Complete bit of the Standard Event Status Register to be set when all pending operations are complete. See section 3.2.2.
*OPC[n]?	Returns the integer value “1” when all pending operations are complete. See section 3.2.2. Response: <0+NR1>
*RST[n]	Resets the supply to its Power ON (PON) state. Clears all status reporting data structures including the Status Byte, Standard Event Status Register, and Error Queue. The STAT:PROT:ENAB (protection event enable register) is cleared by this command; other enable registers are not cleared by this command.
*SRE[n] <0+NR1>	Sets the value of the Service Request Enable Register which determines which bits in the Status Byte will cause a service request from the device. See section on Status Byte for valid values.
*SRE[n]?	Returns the integer value of the Service Request Enable Register. See section on Status Byte for valid values. Values range from 0-63 or 128-191. Response: <0+NR1>

Command	Description
*STB[n]?	<p>Returns the integer value of the Status Byte with bit 6 representing the Master Summary Status (MSS) instead of RQS. The MSS bit acts as a summary bit for the Status Byte and indicates whether the device has at least one reason to request service based on the MAV and the ESR bits. The Status Byte is cleared. See section on Status Byte for valid values. Values range from 0-255.</p> <p>Response: <0+NR1></p>
*TST[n]?	<p>Sets the device to execute an internal self-test and return the integer value of the results. Value of "0" indicates no errors.</p> <p>Response: <0+NR1></p>
*WAI[n]	<p>Sets the device to wait until all previous commands and queries are complete before executing commands following the *WAI command.</p>

3.5 CALIBRATION SCPI Command Subsystem

See section 4.0 for calibration procedures.



WARNING

Please refer to the power supply manual for further information before performing calibration procedures. Calibration must be performed by qualified personnel who appropriately deal with attendant hazards. If calibration is not performed properly, functional problems could arise, requiring that the supply be returned to the factory.

3.5.1 CALIBRATION SCPI Command Summary

CALibrate[n]

:DATA <NRf><NRf><NRf><NRf><NRf><NRf><NRf><NRf><NRf><NRf>

:INITial

:CURRent <0+NRf>

:VOLTage

[:AMPLitude] <NRf>

:PROTection <NRf>

:LOCK

:MEASure

:CURRent

:ADC?

:CALCulate

:GAIN <NRf>

:OFFSet <NRf>

:POINt <1|2> <0+NRf>

:VOLTage

:ADC?

:CALCulate

:GAIN <NRf>

:OFFSet <NRf>

:POINt <1|2> <NRf>

:OUTPut

:CURRent

:CALCulate

:DAC <0+NR1>

:GAIN <NRf>

:OFFSet <NRf>

:POINt <1|2> <NRf>

:VOLTage

:CALCulate

:DAC <0+NR1>

:GAIN <NRf>

:OFFSet <NRf>

:POINt <1|2> <NRf>

:PROTection

:CALCulate

:DAC <0+NR1>

:GAIN <NRf>

:OFFSet <NRf>

:STORe

:UNLock <string>

3.5.2 CALIBRATION SCPI Command Reference

Command	Description	SCPI
CALibrate[n]	Calibration subsystem. n = 1-31. The default channel is 1.	C
:DATA <NRf><NRf><NRf> <NRf><NRf><NRf> <NRf><NRf><NRf> <NRf>	Sets the values of the ten floating point calibration constants: 1) output voltage DAC gain 2) output voltage DAC offset 3) output current DAC gain 4) output current DAC offset 5) output voltage protection DAC gain 6) output voltage protection DAC offset 7) voltage measurement ADC gain 8) voltage measurement ADC offset 9) current measurement ADC gain 10) current measurement ADC offset Values are separated by space or comma.	N
:INITial		N
:CURRent	Sets the power-on default value of current.	N
:VOLTage		N
[:AMPLitude] <NRf>	Sets the power-on default voltage.	N
:PROTection <NRf>	Sets the power-on default value of the overvoltage protection.	N
:LOCK	Disables access to the non-volatile memory. Prevents attempts to store calibration values.	N
:MEASure		N
:CURRent		
:ADC?	Returns the integer value of the A/D for the current measurement.	N
:CALCulate	Calculates the value of the gain and offset for current measurements.	N
:GAIN <NRf>	Sets the value of the gain for current measurements.	N
:OFFSet <NRf>	Sets the value of the offset for current measurements.	N
:POINt <1 2> <0+NRf>	Sets the current measurement calibration point (1 or 2). The actual output current is measured with an external meter.	N
:VOLTage		N
:ADC?	Returns the integer value of the A/D for the voltage measurement.	N
:CALCulate	Calculates the value of the gain and offset for voltage measurements.	N
:GAIN <NRf>	Sets the value of the gain for voltage measurements.	N
:OFFSet <NRf>	Sets the value of the offset for voltage measurements.	N

Command	Description	SCPI
:POINT <1 2> <NRf>	Sets the voltage measurement calibration point (1 or 2). The actual output voltage is measured with an external meter.	N
:OUTPut		N
:CURRent		N
:CALCulate	Calculates the value of the gain and offset for output current.	N
:DAC <0+NR1>	Sets the output of the output current D/A converter. The value range is 0 - 4095.	N
:GAIN <NRf>	Sets the value of the gain for the output current.	N
:OFFSet <NRf>	Sets the value of the offset for the output current.	N
:POINT <1 2> <0+NRf>	Sets the current output calibration point (1 or 2). The actual output current is measured with an external meter.	N
:VOLTage		N
:CALCulate	Calculates the value of the gain and offset for output voltage.	N
:DAC <0+NR1>	Sets the output of the output voltage D/A converter. The value range is 0 - 4095.	N
:GAIN <NRf>	Sets the value of the gain for the output voltage.	N
:OFFSet <NRf>	Sets the value of the offset for the output voltage.	N
:POINT <1 2> <NRf>	Sets the voltage output calibration point (1 or 2). The actual output voltage is measured with an external meter.	N
:PROTection		N
:CALCulate	Calculates the value of the gain and offset for output overvoltage protection. This takes more than 30 seconds to complete. Use *ESE 1 and a serial poll to detect the completed operation.	N
:DAC <0+NR1>	Sets the output of the output overvoltage protection D/A converter. The value range is 0 - 4095.	N
:GAIN <NRf>	Sets the value of the gain for the output overvoltage protection.	N
:OFFSet <NRf>	Sets the value of the offset for the output overvoltage protection.	N
:STORe	Stores the calibration constants in non-volatile memory.	N
:UNLock <string>	Sets the non-volatile memory available to store calibration constants. The access string is "6867".	N

3.6 MEASURE SCPI Command Subsystem

3.6.1 MEASURE SCPI Command Summary

```

MEASure[n]
  :CURRent?
  :CURRent
    :AVERage <value>
    :AVERage?
  :VOLTage?
  : VOLTage
    :AVERage <value>
    :AVERage?

```

3.6.2 MEASURE SCPI Command Reference

Command	Description	SCPI
MEASure[n]	Measure subsystem. n = 1-31. The default channel is 1.	C
:CURRent?	Returns the floating point value of the DC output current in amps.	C
:CURRent		
:AVERage <value>	Enter a value of 1 to 5 to set the number of readings to average together when returning the current value from the MEAS:CURR? command. This function reduces noise in the readback readings. The (default) value of 1 provides the fastest response time, but the noisiest readings. Available for DLM Series firmware versions 1.08 and later.	—
:AVERage?	Returns the number 1 to 5 to indicate the last set number of readings to average together when taking a current reading. Available for DLM Series firmware versions 1.08 and later.	—
:VOLTage?	Returns the floating point value of the DC output voltage in volts.	C
: VOLTage		
:AVERage <value>	Enter a value of 1 to 5 to set the number of readings to average together when returning the voltage value from the MEAS:VOLT? command. This function reduces noise in the readback readings. The (default) value of 1 provides the fastest response time, but the noisiest readings. Available for DLM Series firmware versions 1.08 and later.	—
:AVERage?	Returns the number 1 to 5 to indicate the last set number of readings to average together when taking a voltage reading. Available for DLM Series firmware versions 1.08 and later.	—

3.7 OUTPUT SCPI Command Subsystem

3.7.1 OUTPUT SCPI Command Summary

OUTPut[n]

```

:PROTection
    :DELaY <0+NRf>
    :FOLD <0|1|2>
:STATe <boolean>
:TRIPped?

```

3.7.2 OUTPUT SCPI Command Reference

Command	Description	SCPI
OUTPut[n]	Output subsystem. n = 1-31. The default channel is 1.	C
:PROTection		N
:DELaY <0+NRf>	Sets the programmable time delay executed by the supply before reporting output protection conditions after a new output voltage or current is specified.	N
:FOLD <0 1 2>	Sets the foldback (program down) mode of the supply. Valid arguments are 0 (OFF or do nothing, do not program down to zero), 1 (program down to zero upon entering constant-voltage mode), or 2 (program down to zero upon entering constant-current mode).	N
:STATe <boolean>	Sets the output to zero or the programmed value; opens or closes the isolation relay. Valid arguments are 1/ON or 0/OFF. *RST state value is ON. CAUTION: Ensure that suitable delays are incorporated to preclude hot switching of the isolation relay.	C
:TRIPped?	Returns the integer value 1 (TRIPPED) or 0 (UNTRIPPED) state of the output.	N

3.8 SOURCE SCPI Command Subsystem

3.8.1 SOURCE SCPI Command Summary

```

SOURCE[n]
  :CURRent
    [:LEVel]
      [:IMMediate]
        [:AMPLitude] <0+NRf>
      :TRIGgered
        :CLEar
          [:AMPLitude] <0+NRf>
      :LIMit
        [:AMPLitude] <0+NRf>
      :RAMP <0+NRf> <0+NRf>
      :ABORt
      :ALL?
      :TRIGgered <0+NRf> <0+NRf>
  :ONLine?
  :STATus
    :BLOCk?
    :REGister?
  :TIMEout?
  :VOLTage
    [:LEVel]
      [:IMMediate]
        [:AMPLitude] <NRf>
      :TRIGgered
        :CLEar
          [:AMPLitude] <NRf>
      :LIMit
        [:AMPLitude] <NRf>
    :PROTection
      [:LEVel] <NRf>
      :TRIPped?
      :STATe?
    :RAMP <NRf> <0+NRf>
    :ABORt
    :ALL?
    :TRIGgered <NRf> <0+NRf>

```

3.8.2 SOURCE SCPI Command Reference

Command	Description	SCPI
SOURce[n]	Source subsystem. n = 1-31. The default channel is 1.	C
:CURRent	Sets the output current in amps (default) or in milliamps.	C
[:LEVel]	Sets the output current in amps (default) or in milliamps.	C
[:IMMediate]	Sets the output current in amps (default) or in milliamps.	C
[:AMPLitude] <0+NRf>	Sets the output current in amps (default) or in milliamps.	C
:TRIGgered	Sets the value of the output current to be implemented by the trigger.	C
:CLEar	Clears the trigger mode.	
[:AMPLitude] <0+NRf>	Sets the value of the output current to be implemented by the trigger.	C
:LIMit	Sets an upper soft limit on the programmed output current for the supply.	C
[:AMPLitude] <0+NRf>	Sets an upper soft limit on the programmed output current for the supply.	C
:RAMP <0+NRf> <0+NRf>	Sets the output current to ramp from the present value to the specified value (first argument) in the specified time (second argument). See ramp description below.	N
:ABORt	Aborts ramping and clears trigger mode.	
:ALL?	Returns the ramping status of all channels.	
:TRIGgered <0+NRf> <0+NRf>	Sets the output current to ramp from the present value to the specified value (first argument) in the specified time (second argument) upon the trigger command. See ramp description below.	N
:ONLine?	Returns the integer value 1(ONLINE) or 0 (OFFLINE) of the channel online status.	N

Command	Description	SCPI
:STATus		
:BLOCk?	Returns the block of data critical to the status of the channel: 1) channel number 2) online status 3) status flags register (see table below) 4) status register 5) accumulated status 6) fault mask register 7) fault register 8) error register 9) model serial number 10) model voltage 11) model current 12) model over-voltage 13) output voltage DAC gain 14) output voltage DAC offset 15) output current DAC gain 16) output current DAC offset 17) output voltage protection DAC gain 18) output voltage protection DAC offset 19) voltage measurement ADC gain 20) voltage measurement ADC offset 21) current measurement ADC gain 22) current measurement ADC offset 23) model string 24) OVP calibrated Each value is separated by commas.	N
:REGister?	Returns the integer value of the status register.	N
:TIMeout?	Returns the integer value 1 (timeout since last query) or 0 (no timeout) of the timeout status of the channel.	N
:VOLTage	Sets the output voltage of the supply in volts (default) or in millivolts.	C
[:LEVel]	Sets the output voltage of the supply in volts (default) or in millivolts.	C
[:IMMediate]	Sets the output voltage of the supply in volts (default) or in millivolts.	C
[:AMPLitude] <NRf>	Sets the output voltage of the supply in volts (default) or in millivolts.	C
:TRIGgered	Sets the value of the output voltage to be implemented by the trigger.	C
:CLEar	Clears the trigger mode.	
[:AMPLitude] <NRf>	Sets the value of the output voltage to be implemented by the trigger.	C
:LIMit	Sets the upper soft limit on the programmed output voltage.	C

Command	Description	SCPI
[:AMPLitude] <NRf>	Sets the upper soft limit on the programmed output voltage.	C
:PROTection	Sets the overvoltage protection trip point in volts (default) or in millivolts.	C
[:LEVe] <NRf>	Sets the overvoltage protection trip point in volts (default) or in millivolts.	C
:TRIPped?	Returns the integer value 1 (TRIPPED) or 0 (UNTRIPPED) state of the overvoltage protection.	C
:STATe?	Returns the integer value 1 (ON) or 0 (OFF) state of the overvoltage protection.	C
:RAMP <NRf> <0+NRf>	Sets the output voltage to ramp from the present value to the specified value (first argument) in the specified time (second argument). See ramp description below.	N
:ABORt	Aborts ramping and clears trigger mode.	
:ALL?	Returns the ramping status of all channels.	
:TRIGgered <NRf> <0+NRf>	Sets the output voltage to ramp from the present value to the specified value (first argument) in the specified time (second argument) upon the trigger command. See description of Ramp Function below.	N

THE RAMP FUNCTION

The ramp function allows the user to transition from one voltage or current to another linearly in a specified time period (100 ms - 99 sec with 100 ms programming resolution). The ramp-upon-trigger function may be used to program different ramping parameters for several units then trigger them all to begin their ramps at the same time. A unit may ramp only voltage or current, not both at a given time. For example, SOUR:VOLT:RAMP:TRIG 1 1 followed by SOUR:CURR:RAMP:TRIG 2 2 will cause the unit to ramp only the output current to 2 amps in 2 seconds upon the TRIG:RAMP command.

Voltage ramping to a higher voltage requires a programmed current of at least 20% of the full scale value. Settings less than 20% will significantly lengthen the ramp time due to charging of the large capacitance in the output section of the power supply.

Voltage ramping to a lower voltage requires an appropriate resistive load. The discharge rate of the large capacitance in the output section of the power supply, plus other user capacitance, significantly lengthens the ramp time.

Current ramping requires an appropriate resistive load.

SOURce[n]:STATus:BLOCK? "Status Flags" REGISTER

Bit	Hex Value	Name	Description
0	0x001	remote mode	Remote mode was selected.
1	0x002	polarity signal	Negative voltage programmed. Polarity relay signal is on.
2	0x004	PON SRQ	PON Service Request selected by rear panel switch.
3	0x008	SRQ sent	GPIB Service Request issued and the serial poll has not been received.
4	0x010	EEPROM	The EEPROM is locked.
5	0x020	trip occurred	Either an OV or OT trip occurred.
6	0x040	sense signal	Sense relay signal is on.
7	0x080	isolation signal	Isolation relay signal is on.
8	0x100	hold	Voltage and current output waiting for trigger.
9	0x200	fold	Foldback protection is enabled.
10	0x400	SRQ enabled	Service Request generation is enabled.
11	0x800	output	Output is on.

3.9 STATUS SCPI Command Subsystem

3.9.1 STATUS SCPI Command Summary

STATUs[n]

```

:OPERation
    :CONDition?
    :ENABle <0+NR1>
    :EVENT?
:PRESet
:PROTection
    :CONDition?
    :ENABle <0+NR1>
    :EVENT?
    :SELEct <0+NR1>
:QUESTionable
    :CONDition?
    :ENABle <0+NR1>
    :EVENT?

```

3.9.2 STATUS SCPI Command Reference

Command	Description	SCPI
STATUs[n]	Status subsystem. n = 1-31. The default channel is 1.	C
:OPERation		C
:CONDition?	Returns the integer value of the Operation Condition Register. The query is supported but will always return "0" indicating operational condition.	C
:ENABle <0+NR1>	Sets the enable mask of the Operation Event Register allowing true conditions to be reported in the summary bit of the Operation Condition Register. Values are written and queried but have no effect on the Operation Condition Register.	C
:EVENT?	Returns the integer value of the Operation Event Register. This query is supported but always returns a value of "0", indicating operational condition.	C
:PRESet	Sets the enable mask of the Operation Event Register and the Questionable Event Register to all 1's.	C
:PROTection		C
:CONDition?	Returns the integer value of the Protection Condition Register. Used to read the status of the power hardware. See section 3.2.3. for a detailed table of the various bits that make up this register.	C

Command	Description	SCPI
:ENABle <0+NR1>	Sets the enable mask of the Protection Event Register which allows true conditions to be reported in the summary bit of the Protection Condition Register.	C
:EVENT?	Returns the integer value of the Protection Event Register.	C
:QUESTionable		C
:CONDition?	Returns the integer value of the Questionable Condition Register. The query is supported but will always return "0" indicating operational condition.	C
:ENABle <0+NR1>	Sets the enable mask of the Questionable Event Register allowing true conditions to be reported in the summary bit of the Questionable Condition Register. Values are written and queried but have no effect on the Questionable Condition Register.	C
:EVENT?	Returns the integer value of the Questionable Event Register. This query is supported but always returns a value of "0", indicating operational condition.	C

3.10 SYSTEM SCPI Command Subsystem

3.10.1 SYSTEM SCPI Command Summary

SYSTem

:ERRor?
 :FAULt?
 :VERsion?
 :LOCAL <boolean>

3.10.2 SYSTEM SCPI Command Reference

Command	Description	SCPI
SYSTem	System subsystem.	C
:ERRor?	Queries Error Queue for next error/event entry (first in, first out). Entries contain an error number and descriptive text. A 0 return value indicates no error occurred; negative numbers are reserved by SCPI. The maximum return string length is 255 characters. The queue holds up to 10 error/entries. All entries are cleared by the *CLS command.	C
:FAULt?	Returns four numeric values separated by commas for the four system fault registers. See System Fault Registers below (e.g., 1, 1, 2, 4 indicates ch 1, 9, 18, and 27 each have at least one fault). Response: <Fault1–8>, <Fault9–16>, <Fault17–24>, <Fault25–31>	N
:VERsion?	Returns a numeric value corresponding to the SCPI version number for which the instrument complies. The response is in the format YYYY.V where the Y's represent the year and V represents the approved version number for that year (e.g., 1995.0)	C

Command	Description	SCPI
SYST[n]:LOCAL	<p>SYST[n]:LOCAL <ON OFF> is a special purpose programming command that may be used to cause source [n] to be set to the local state or to the remote state. This command has two noteworthy circumstances under which it may prove necessary. The first case involves using RS232 to communicate with the supply, since the normal GPIB mechanisms for transition between local and remote and back again do not exist when using RS232. The other case is when the REMOTE/LOCAL switch S1-1 is placed in the ON position—thereby disabling the GPIB mechanism for transition from remote to local. The SYST[n]:LOCAL ON command provides a means for the system computer to force source [n] to the local state. Also, the SYST[n]:LOCAL? query command is available to examine the local-remote state of the supply. And the command SYST[n]:LOCAL OFF may be used to force supply [n] to the remote state.</p>	N
SYST[n]:LOCAL:LOCKOUT	<p>The SYST[n]:LOCAL:LOCKOUT <0 1 OFF ON> command provides a means of controlling the local lockout functionality that is an alternative to the low level GPIB LLO command. A source number may be specified with this command, thereby allowing selective disabling of the front panel of a selected source.</p> <p>In contrast, using the GPIB LLO low level command causes the master supply, and all attached online slaves, to be placed into the local lockout state. To place the master and all online slaves into the local lockout state using the SYST[n]:LOCAL:LOCKOUT command, specify the source number of 0.</p> <p>To place only one slave into the local lockout state, specify that slave in the command. For example, if the slave is source 3, use the command: SYST3:LOCAL:LOCKOUT 1.</p>	

SYSTEM FAULT REGISTERS

Bit Position	Bit Weight	Fault1–8	Fault9–16	Fault17–24	Fault25–31
7	128	Channel 8	Channel 16	Channel 24	not used
6	64	Channel 7	Channel 15	Channel 23	Channel 31
5	32	Channel 6	Channel 14	Channel 22	Channel 30
4	16	Channel 5	Channel 13	Channel 21	Channel 29
3	8	Channel 4	Channel 12	Channel 20	Channel 28
2	4	Channel 3	Channel 11	Channel 19	Channel 27
1	2	Channel 2	Channel 10	Channel 18	Channel 26
0	1	Channel 1	Channel 9	Channel 17	Channel 25

The R Option provides four System Fault Registers to allow the user to monitor the fault status of a multiple-channel system. For example, the user may poll these registers to quickly determine which channel generated an enabled GPIB service request.

The SYStem:FAULT? query returns 4 numeric values separated by commas. Each value is the decimal equivalent of the total bit weights for that System Fault Register as described in the table above.

3.11 TRIGGER SCPI Command Subsystem

3.11.1 TRIGGER SCPI Command Summary

TRIGger[n]

:ABORt

:RAMP

:TYPE <1|2|3>

3.11.2 TRIGGER SCPI Command Reference

Command	Description	SCPI
TRIGger[n]	Trigger subsystem. N = 0, 1-31. The default channel is 1. A value of n = 0 will program all channels.	C
:ABORt	Clears all settings of voltage and current upon trigger.	N
:RAMP	Implements current or voltage ramping function previously programmed by the SOURce:CURRent:RAMP or SOURce:VOLTage:RAMP commands.	N
:TYPE<1 2 3>	Implements voltage and current values previously programmed by the SOURce:CURRent:LEVel:TRIGger and SOURce:VOLTage:LEVel:TRIGger commands. Valid arguments are 1 (Voltage), 2 (Current), or 3 (Both).	N

3.12 Examples of Using the SCPI Commands

The following examples demonstrate programming a power supply to control and to readback the output using the SCPI commands. The maximum voltage and current output is dependent on the particular model. The examples list only the SCPI commands; the code required to send the commands is dependent on the type of language you are using (e.g., C or BASIC) and GPIB hardware (e.g., National Instruments).

EXAMPLE: Program a unit with no load at the output to 5 VDC @ 1A, and verify the output.

```
// Use SYST:ERR? after each command to verify no programming errors.
// turn on the unit.
*CLS // clear the unit to its power-on default settings.
*RST // reset the unit.
SOUR:CURREN 1.0 // program output current to 1.0 A.
SOUR:CURREN? // confirm the output current setting (response: 1.0).
SOUR:VOLT 5.0 // program output voltage to 5.0 VDC.
SOUR:VOLT? // confirm the output voltage setting (response: 5.0).
MEAS:CURREN? // measure the actual output current (response: ~ 0.0 with no load on
output).
MEAS:VOLT? // measure the actual output voltage (response: ~ 5.0).
```

EXAMPLE: Program a unit with no load at the output to generate a GPIB service request upon an overvoltage protection trip condition. (Must use GPIB not RS-232.)

```
// Use SYST:ERR? after each command to verify no programming errors.
// assure that PON is not selected on the rear panel switch
// and the front panel SRQ led is OFF. Turn on the unit.
*CLS // clear the unit to its power-on default settings.
*RST // reset the unit.
SOUR:VOLT:PROT 4.0 // program the OVP trip point to 4.0 VDC.
SOUR:VOLT:PROT? // confirm the OVP trip point setting (response: 4.0).
SOUR:CURREN 1.0 // program output current to 1.0 A.
SOUR:VOLT 3.0 // program output voltage to 3.0 VDC.
STAT:PROT:ENABLE 8 // program the unit to report OVP trip.
STAT:PROT:ENABLE? // confirm that OVP fault is enabled (response: 8).
*SRE 2 // enable the GPIB service request upon a fault.
*SRE? // confirm the GPIB service request enabled (response 2).
STAT:PROT:EVENT? // confirm no faults occurred (response: 0).
// confirm that the OVP led and SRQ led is not active.
SOUR:VOLT 7.0 // program output voltage to 7.0 VDC - cause OVP trip!
// confirm that OVP led and SRQ led is active, and unit issued a GPIB service request (use a
serial poll).
```

EXAMPLE: Program a unit with no load at the output to change its output voltage and current to 5 VDC @ 1A at the same time.

```
// Use SYST:ERR? after each command to verify no programming errors.
// turn on the unit.
*CLS // clear the unit to its power-on default settings.
*RST // reset the unit.
SOUR:CURREN:TRIG1.0 // program output current to 1.0 A upon trigger.
SOUR:CURREN:TRIG? // confirm output current set to 1.0 A upon trigger.
SOUR:VOLT:TRIG5.0 // program output voltage to 5.0 VDC upon trigger
SOUR:VOLT:TRIG? // confirm output current set to 5.0 VDC upon trigger.
MEAS:CURREN? // measure the actual output current (response: 0.0).
MEAS:VOLT? // measure the actual output voltage (response: 0.0).
TRIG:TYPE 3 // trigger the unit to implement curr and volt programming.
MEAS:CURREN? // measure the actual output current (response: ~ 0.0 with no load
on output).
MEAS:VOLT? // measure the actual output voltage (response: ~ 5.0).
TRIG:ABORT // turn off trigger mode.
```

EXAMPLE: Program a unit with no load at the output to ramp its output voltage from 5 VDC to 25 VDC in 30 seconds.

Note: The maximum output voltage is dependent upon the power supply rating.

```
// Use SYST:ERR? after each command to verify no programming errors.
// turn on the unit.
*CLS // clear the unit to its power-on default settings.
*RST // reset the unit.
SOUR:CURREN 33.0 // program output current to 33.0 A.
SOUR:VOLT 5.0 // program output voltage to 5.0 VDC.
SOUR:VOLT:RAMP 25.0 30.0 // program voltage to ramp from the present
// value (5.0 VDC) to 25.0 VDC in 30 seconds.
```

EXAMPLE: Program a unit with the output shorted to ramp its output current from 5A to 25A in 30 seconds.

```
// Use SYST:ERR? after each command to verify no programming errors.
// turn on with no load at the output.
*CLS // clear the unit to its power-on default settings.
*RST // reset the unit.
// short the output.
SOUR:VOLT 33.0 // program output voltage to 33.0 VDC.
SOUR:CURREN 5.0 // program output current to 5.0 A.
SOUR:CURREN:RAMP 25.0 30.0 // program current to ramp from the present
// value (5.0 A) to 25.0 A in 30 seconds.
```

EXAMPLE: Program a unit with no load at the output to ramp its output voltage from 5 VDC to 25 VDC in 30 seconds upon the trigger command.

```
// Use SYST:ERR? after each command to verify no programming errors.
// turn on the unit.
*CLS // clear the unit to its power-on default settings.
*RST // reset the unit.
SOUR:CURR 33.0 // program output current to 33.0 A.
SOUR:VOLT 5.0 // program output voltage to 5.0 VDC.
SOUR:VOLT:RAMP:TRIG 25.0 30.0 // program voltage to ramp from the present
// value (5.0 VDC) to 25.0 VDC in 30 secs.
// upon the trigger command.
TRIG:RAMP // start ramp execution.
TRIG:ABORT // turn off trigger mode.
```

EXAMPLE: Program a unit to power-on and initialize to 2 VDC @ 1A with an overvoltage protection level of 3 VDC. Verify proper power-on initialization.

```
// Use SYST:ERR? after each command to verify no programming errors.
// turn on the unit.
*CLS // clear the unit to its power on default settings.
*RST // reset the unit.
CAL:INIT:CURR 1.0 // set power-on initial current to 1.0 A.
CAL:INIT:CURR? // confirm power-on initial current setting.
CAL:INIT:VOLT 2.0 // set power-on initial voltage to 2.0 VDC.
CAL:INIT:VOLT? // confirm power-on initial voltage setting.
CAL:INIT:VOLT:PROT 3.0 // set power-on initial overvoltage protection to 3.0 VDC.
CAL:INIT:VOLT:PROT? // confirm power-on initial overvoltage protection setting.
CAL:UNLOCK "6867" // unlock nonvolatile memory for calibration value storage.
CAL:STORE // store the calibration values in nonvolatile memory.
CAL:LOCK // lock nonvolatile memory for calibration value protection.
// cycle power to the unit.
// note voltage is initialized to 2.0 VDC via front panel.
SOUR:CURR? // confirm power-on initial current setting.
SOUR:VOLT? // confirm power-on initial voltage setting.
SOUR:VOLT:PROT? // confirm power-on initial overvoltage protection setting.
```

This page intentionally left blank.

SECTION 4 CALIBRATION



WARNING

Please refer to the power supply manual for further information before performing calibration procedures. Calibration must be performed by qualified personnel who appropriately deal with attendant hazards. If calibration is not performed properly, functional problems could arise, requiring that the supply be returned to the factory.

4.1 Introduction

The R Option is calibrated to adjust internal signal levels to correspond to the expected supply output signal levels. You must perform the calibration procedures if the power supply's programming or readback performance falls out of specification due to component aging drifts. Refer to your power supply manual to find the required calibration interval. The R Option is calibrated for output voltage programming, output current programming, output overvoltage protection programming, voltage readback, and current readback. There are 10 calibration factors (four measurement and six output).

The calibration procedures in the following sections are designed to be performed at ambient temperature of $25^{\circ}\text{C} \pm 5^{\circ}\text{C}$, after the unit has had a stable output and a stable load for at least 30 minutes.

The following test equipment is required in addition to the computer system to complete the following calibration:

- 6-digit digital voltmeter (DVM)
- current shunt rated for 110% of full output current

4.2 Setup for Calibration

STEP DESCRIPTION

1. Disconnect the power supply's AC input power.
2. Disconnect the load from the power supply you want to calibrate.
3. Connect the power supply for sensing at the required load point. Refer to the power supply manual for further information.
4. Connect the DVM to the output for voltage or overvoltage calibration, or connect a current shunt rated for the full output current of the supply and the DVM for current calibration.
5. Assure the correct GPIB primary address has been set by the rear panel switch.
6. Set the power supply to REMOTE mode by the rear panel switch.
7. Connect the GPIB controller to the power supply at the rear panel connector.
8. Reconnect the AC input power. Turn the unit ON and allow the unit to warm up for at least 30 minutes.
9. The unit is ready for all calibration procedures.



WARNING

Exercise caution when using and servicing power supplies. High energy levels can be stored at the output voltage terminals on all power supplies in normal operation. In addition, potentially lethal voltages exist in the power circuit and the output connector on power supplies that are rated at 60V and over. Filter capacitors store potentially dangerous energy for some time after power is removed.

4.3 Voltage Programming Calibration

STEP DESCRIPTION

1. Program the overvoltage protection to maximum to prevent nuisance trips:
CAL[n]:OUTP:VOLT:PROT:DAC 4095
2. Program the output current to full scale to prevent Constant-Current operation:
CAL[n]:OUTP:CURR:DAC 4095
3. Program the output of the first calibration point to approximately 15% of full scale voltage by sending the following command string from the computer:
CAL[n]:OUTP:VOLT:DAC 600
4. Let the output settle and measure the voltage with the meter.
5. Enter the actual output voltage corresponding to the DAC value 600 of the first calibration point:
CAL[n]:OUTP:VOLT:POINT 1 <voltage>
6. Program the output of the second calibration point to approximately 85% of full scale voltage by sending the following command string from the computer:
CAL[n]:OUTP:VOLT:DAC 3400
7. Let the output settle and measure the voltage with the meter.
8. Enter the actual output voltage corresponding to the DAC value 3400 of the second calibration point:
CAL[n]:OUTP:VOLT:POINT 2 <voltage>
9. Reset the output voltage to 0 volts.
CAL[n]:OUTP:VOLT:DAC 0
10. Program the R Option to calculate the output voltage calibration gain and offset values:
CAL[n]:OUTP:VOLT:CALC
11. Program the R Option to unlock the non-volatile memory for calibration value storage:
CAL[n]:UNLOCK "6867"
12. Program the R Option to store the calibration values in non-volatile memory:
CAL[n]:STORE

13. Program the R Option to lock the non-volatile memory for calibration value protection
CAL[n]:LOCK
14. The output voltage calibration is complete. The unit may be turned OFF or other calibration procedures may be performed.

4.4 Voltage Measurement/Readback Calibration

STEP DESCRIPTION

1. Program the overvoltage protection to maximum to prevent nuisance trips:
CAL[n]:OUTP:VOLT:PROT:DAC 4095
2. Program the output current to full scale to prevent Constant-Current operation:
CAL[n]:OUTP:CURR:DAC 4095
3. Program the output of the first calibration point to approximately 15% of full scale voltage by sending the following command string from the computer:
CAL[n]:OUTP:VOLT:DAC 600
4. Let the output settle and measure the voltage with the meter.
5. Enter the actual voltage readback corresponding to the DAC value 600 of the first calibration point:
CAL[n]:MEAS:VOLT:POINT 1 <voltage>
6. Program the output of the second calibration point to approximately 85% of full scale voltage by sending the following command string from the computer:
CAL[n]:OUTP:VOLT:DAC 3400
7. Let the output settle and measure the voltage with the meter.
8. Enter the actual voltage readback corresponding to the DAC value 3400 of the second calibration point:
CAL[n]:MEAS:VOLT:POINT 2 <voltage>
9. Reset the output voltage to 0 volts.
CAL[n]:OUTP:VOLT:DAC 0
10. Program the R Option to calculate the voltage readback calibration gain and offset values:
CAL[n]:MEAS:VOLT:CALC

11. Program the R Option to unlock the non-volatile memory for calibration value storage:
CAL[n]:UNLOCK "6867"
12. Program the R Option to store the calibration values in non-volatile memory:
CAL[n]:STORE
13. Program the R Option to lock the non-volatile memory for calibration value protection
CAL[n]:LOCK
14. The voltage readback calibration is complete. The unit may be turned OFF or other calibration procedures may be performed.

4.5 Overvoltage Protection Programming Calibration

The overvoltage protection calibration procedure requires calibrated output voltage programming and voltage readback.

STEP DESCRIPTION

1. Program the R Option to self-calibrate the overvoltage protection:
CAL[n]:OUTP:VOLT:PROT:CALC
The overvoltage protection calibration function requires over 30 seconds. Use *ESE 1 and serial polls to detect when calibration is done.
2. Program the R Option to unlock the non-volatile memory for calibration value storage:
CAL[n]:UNLOCK "6867"
3. Program the R Option to store the calibration values in non-volatile memory:
CAL[n]:STORE
4. Program the R Option to lock the non-volatile memory for calibration value protection
CAL[n]:LOCK
5. The output overvoltage protection calibration is complete. The unit may be turned OFF or other calibration procedures may be performed.

4.6 Current Programming Calibration

STEP DESCRIPTION

1. Program the overvoltage protection to maximum to prevent nuisance trips:
CAL[n]:OUTP:VOLT:PROT:DAC 4095
2. Program the output voltage to full scale to prevent Constant-Voltage operation:
CAL[n]:OUTP:VOLT:DAC 4095
3. Program the output of the first calibration point to approximately 15% of full scale current by sending the following command string from the computer:
CAL[n]:OUTP:CURR:DAC 600
4. Let the output settle and measure the current with the current shunt and the meter.
5. Enter the actual output current corresponding to the DAC value 600 of the first calibration point:
CAL[n]:OUTP:CURR:POINT 1 <current>
6. Program the output of the second calibration point to approximately 85% of full scale current by sending the following command string from the computer:
CAL[n]:OUTP:CURR:DAC 3400
7. Let the output settle and measure the current with the current shunt and the meter.
8. Enter the actual output current corresponding to the DAC value 3400 of the second calibration point:
CAL[n]:OUTP:CURR:POINT 2 <current>
9. Reset the output current to 0 amps.
CAL[n]:OUTP:CURR:DAC 0
10. Program the R Option to calculate the output current calibration gain and offset values:
CAL[n]:OUTP:CURR:CALC
11. Program the R Option to unlock the non-volatile memory for calibration value storage:
CAL[n]:UNLOCK "6867"
12. Program the R Option to store the calibration values in non-volatile memory:
CAL[n]:STORE

13. Program the R Option to lock the non-volatile memory for calibration value protection
CAL[n]:LOCK
14. The output current calibration is complete. The unit may be turned OFF or other calibration procedures may be performed.

4.7 Current Measurement/Readback Calibration

STEP DESCRIPTION

1. Program the overvoltage protection to maximum to prevent nuisance trips:
CAL[n]:OUTP:VOLT:PROT:DAC 4095
2. Program the output voltage to full scale to prevent Constant-Voltage operation:
CAL[n]:OUTP:VOLT:DAC 4095
3. Program the output of the first calibration point to approximately 15% of full scale current by sending the following command string from the computer:
CAL[n]:OUTP:CURR:DAC 600
4. Let the output settle and measure the current with the current shunt and the meter.
5. Enter the actual current readback corresponding to the DAC value 600 of the first calibration point:
CAL[n]:MEAS:CURR:POINT 1 <current>
6. Program the output of the second calibration point to approximately 85% of full scale current by sending the following command string from the computer:
CAL[n]:OUTP:CURR:DAC 3400
7. Let the output settle and measure the current with the current shunt and the meter.
8. Enter the actual current readback corresponding to the DAC value 3400 of the second calibration point:
CAL[n]:MEAS:CURR:POINT 2 <current>
9. Reset the output current to 0 amps.
CAL:OUTP:CURR:DAC 0
10. Program the R Option to calculate the current readback calibration gain and offset values:
CAL[n]:MEAS:CURR:CALC

11. Program the R Option to unlock the non-volatile memory for calibration value storage:
CAL[n]:UNLOCK "6867"
12. Program the R Option to store the calibration values in non-volatile memory:
CAL[n]:STORE
13. Program the R Option to lock the non-volatile memory for calibration value protection
CAL[n]:LOCK
14. The current readback calibration is complete. The unit may be turned OFF or other calibration procedures may be performed.

4.8 Voltage Programming and Readback Calibration

This procedure may be used to save time if both the output and readback require calibration.

STEP DESCRIPTION

1. Program the overvoltage protection to maximum to prevent nuisance trips:
CAL[n]:OUTP:VOLT:PROT:DAC 4095
2. Program the output current to full scale to prevent Constant-Current operation:
CAL[n]:OUTP:CURR:DAC 4095
3. Program the output of the first calibration point to approximately 15% of full scale voltage by sending the following command string from the computer:
CAL[n]:OUTP:VOLT:DAC 600
4. Let the output settle and measure the voltage with the meter.
5. Enter the actual output voltage corresponding to the DAC value 600 of the first calibration point:
CAL[n]:OUTP:VOLT:POINT 1 <voltage>
CAL[n]:MEAS:VOLT:POINT 1 <voltage>
6. Program the output of the second calibration point to approximately 85% of full scale voltage by sending the following command string from the computer:
CAL[n]:OUTP:VOLT:DAC 3400
7. Let the output settle and measure the voltage with the meter.
8. Enter the actual output voltage corresponding to the DAC value 3400 of the second calibration point:
CAL[n]:OUTP:VOLT:POINT 2 <voltage>

CAL[n]:MEAS:VOLT:POINT 2 <voltage>

9. Reset the output voltage to 0 volts.

CAL[n]:OUTP:VOLT:DAC 0

10. Program the R Option to calculate the output voltage and the voltage measurement calibration gain and offset values:

CAL[n]:OUTP:VOLT:CALC
CAL[n]:MEAS:VOLT:CALC

11. Program the R Option to unlock the non-volatile memory for calibration value storage:

CAL[n]:UNLOCK "6867"

12. Program the R Option to store the calibration values in non-volatile memory:

CAL[n]:STORE

13. Program the R Option to lock the non-volatile memory for calibration value protection.

CAL[n]:LOCK

14. The output voltage and voltage measurement calibrations are completed at the same time. The unit may be turned OFF or other calibration procedures may be performed.

4.9 Current Programming and Readback Calibration

This procedure may be used to save time if both the output and readback require calibration.

STEP DESCRIPTION

1. Program the overvoltage protection to maximum to prevent nuisance trips:

CAL[n]:OUTP:VOLT:PROT:DAC 4095

2. Program the output voltage to full scale to prevent Constant-Voltage operation:

CAL[n]:OUTP:VOLT:DAC 4095

3. Program the output of the first calibration point to approximately 15% of full scale current by sending the following command string from the computer:

CAL[n]:OUTP:CURR:DAC 600

4. Let the output settle and measure the current with the current shunt and the meter.

5. Enter the actual output current corresponding to the DAC value 600 of the first calibration point:

CAL[n]:OUTP:CURR:POINT 1 <current>
CAL[n]:MEAS:CURR:POINT 1 <current>

6. Program the output of the second calibration point to approximately 85% of full scale current by sending the following command string from the computer:

```
CAL[n]:OUTP:CURR:DAC 3400
```

7. Let the output settle and measure the current with the current shunt and the meter.
8. Enter the actual output current corresponding to the DAC value 3400 of the second calibration point:

```
CAL[n]:OUTP:CURR:POINT 2 <current>  
CAL[n]:MEAS:CURR:POINT 2 <current>
```

9. Reset the output current to 0 amps.

```
CAL[n]:OUTP:CURR:DAC 0
```

10. Program the R Option to calculate the output current and current measurement calibration gain and offset values:

```
CAL[n]:OUTP:CURR:CALC  
CAL[n]:MEAS:CURR:CALC
```

11. Program the R Option to unlock the non-volatile memory for calibration value storage:

```
CAL[n]:UNLOCK "6867"
```

12. Program the R Option to store the calibration values in non-volatile memory:

```
CAL[n]:STORE
```

13. Program the R Option to lock the non-volatile memory for calibration value protection

```
CAL[n]:LOCK
```

14. The output current and current measurement calibrations are completed at the same time. The unit may be turned OFF or other calibration procedures may be performed.

SECTION 5

OPERATION WITH THE S OPTION

5.1 Introduction

The following sections describe the operation of the power supply with the S Option and how to configure the option for your application. The S Option is installed at the factory.

The S Option enables you to use your power supply as a slave unit. The master unit would be a power supply with the R Option interface. Both IEEE-488.2 and RS-232 are supported, and the slave -unit or units share the GPIB address or RS-232 interface with the master unit. Up to 30 slave units can be controlled by the master unit.

The S Option can be used with the 1kW and 3kW supplies and supports the SCPI language.

5.2 Configuration

The DIP switch S1, represented in Figure 5–1, is accessible from the rear panel. It allows configuration of the S Option for slave operation. The figure shows the settings for the S Option configured as a slave at channel 2, in remote mode, with no SRQ generated upon initialization.

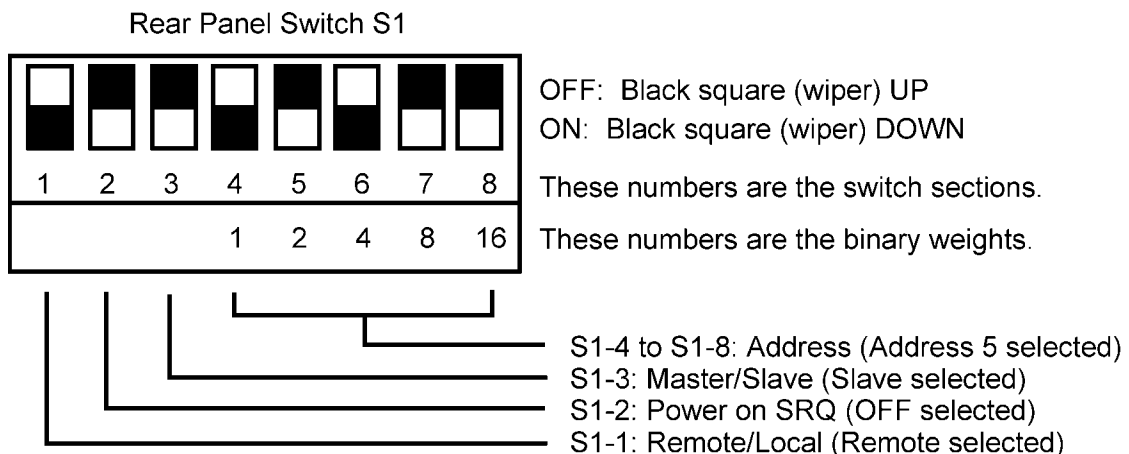

Figure 5–1 S Option–Channel 2 in Remote Mode, S60 Series and S80 Series

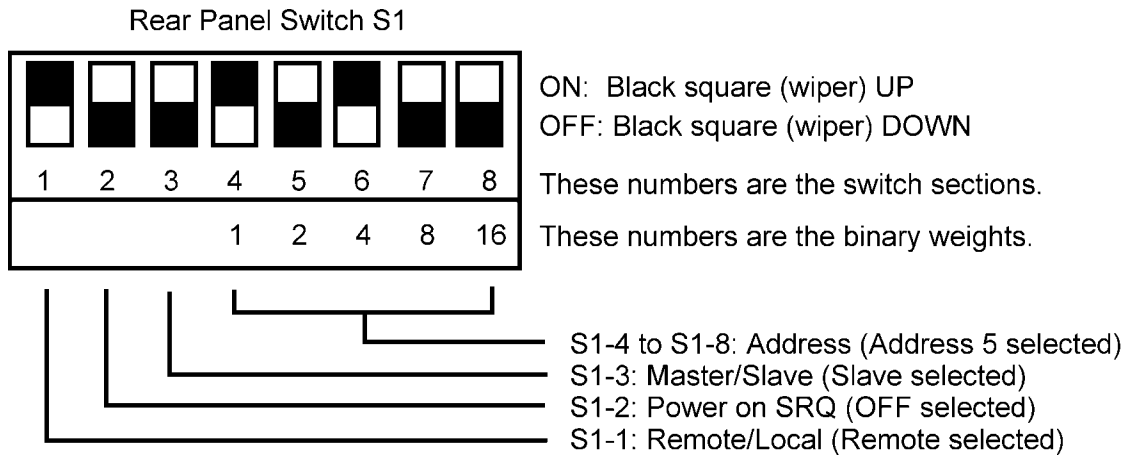

Figure 5–2 S Option–Channel 2 in Remote Mode, S31 Series

See Table 5–1 for definitions of all S1 switch settings:

Table 5–1 Definitions of S1 Switch Settings

Switch	ON	OFF
S1-1	Remote control	Local control
S1-2	PON SRQ ON. Generates GPIB service request to computer/controller when the power supply initializes upon first communication. The front panel SRQ LED will also turn ON. Issuing a serial poll clears service request and turns OFF LED.	Disables GPIB service request upon initialization.
S1-3	Not applicable. Must be OFF.	Unit operates as a slave unit.
S1-4–8	Set channel number for unit in binary:	(Channels 0 and 1 see note below.)
S1-4	Binary 1 ON	Binary 1 OFF
S1-5	Binary 2 ON	Binary 2 OFF
S1-6	Binary 4 ON	Binary 4 OFF
S1-7	Binary 8 ON	Binary 8 OFF
S1-8	Binary 16 ON	Binary 16 OFF

Note: Channel numbers 0 and 1 are invalid for any S Option, because the R Option implementation of the SCPI language reserves channel 0 for the “global” address to address all channels, and it reserves channel number 1 as the default number for the master channel with the R Option.

5.3 System Installation

Follow these steps to install the configured S Option (Slave) into your system. See Figure 5–3.

1. Configure the Slave as described in the Configuration section above.
2. Connect the master unit's RS-485 output connector, J2, to the slave unit's RS-485 input connector, J1, using the modular cable.
3. If there are additional slave units, connect the installed slave unit's RS-485 output connector, J2, to the additional slave unit's RS-485 input connector, J1, using the modular cable.
4. Connect the 120 ohm resistive termination assembly to the last slave unit's J2 connector.
5. Connect power to the system, power it up, and verify that the green REMOTE LED on the front panel is ON.
6. Test the link by communicating with the slave unit from the master unit, using the `*IDN[n]?` command. *Note that [n] is the channel number—for example, `*IDN2?` calls channel 2. (In response to this string, the system returns the power supply model number and the firmware version.)*

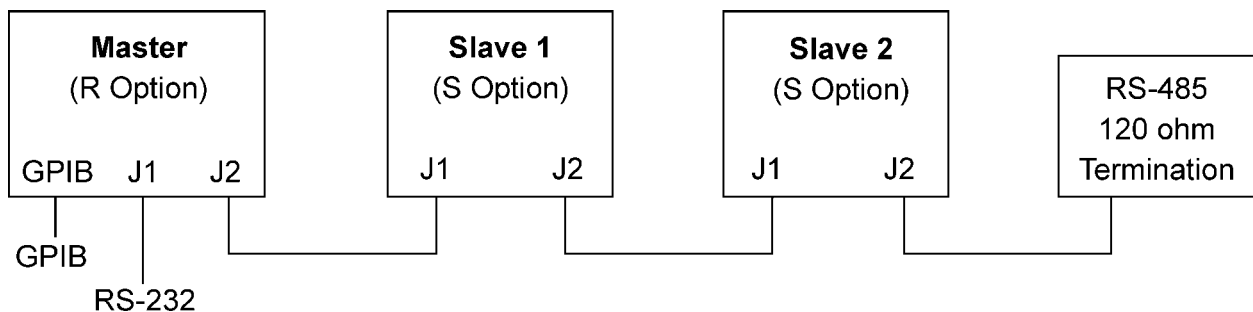

Figure 5–3 RS-485 System Interconnection with Two Slaves (S Options)

5.4 RS-485 Interface

The RS-485 interface is accessible through the two rear-panel, 6-pin, RJ-11 connectors, J1 and J2, depicted in Figure 5–4.

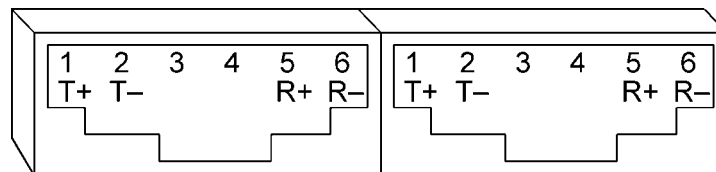

Figure 5–4 S Option Rear Panel RS-485 Connectors Pinout

5.5 Programming the S Option (Example)

The following example programs the S Option (Slave unit) to:

- Turn on
- Initialize to 2 VDC, at 1A
- Set overvoltage protection level at 3 VDC
- Verify proper power-on initialization
- Save and store changes.

// Use SYST:ERR? after each command to verify no programming errors.

// turn on the unit.

```
*CLS // clear the unit to its power on default settings.
*RST // reset the unit.
CAL[n]:INIT:CURR 1.0 // set power-on initial current to 1.0A.
CAL[n]:INIT:CURR? // confirm power-on initial current setting.
CAL[n]:INIT:VOLT 2.0 // set power-on initial voltage to 2.0V.
CAL[n]:INIT:VOLT? // confirm power-on initial voltage setting.
CAL[n]:INIT:VOLT:PROT 3.0 // set power-on initial overvoltage protection to 3.0V.
CAL[n]:INIT:VOLT:PROT? // confirm power-on initial overvoltage protection setting.
CAL[n]:UNLOCK "6867" // unlock nonvolatile memory for calibration value storage.
CAL[n]:STORE // store the calibration values in nonvolatile memory.
CAL[n]:LOCK // lock nonvolatile memory for calibration value protection.
// cycle power to unit.
// note voltage is initialized to 2.0 VDC via front panel.
SOUR[n]:CURR? // confirm power-on initial current setting.
SOUR[n]:VOLT? // confirm power-on initial voltage setting.
SOUR[n]:VOLT:PROT? // confirm power-on initial overvoltage protection setting.
```

INDEX

C

CALibrate[n], 3-10
Calibration
 Current Measurement/Readback
 Calibration, 4-7
 Current Programming and Readback
 Calibration, 4-9
 Current Programming Calibration, 4-6
 Overvoltage Protection Programming
 Calibration, 4-5
 Setup for Calibration, 4-2
 Voltage Measurement/Readback
 Calibration, 4-4
 Voltage Programming and Readback
 Calibration, 4-8
 Voltage Programming Calibration, 4-3
 Warning, 4-1, 4-2
Conventions, 3-7
 [], 3-7

D

Default Master Channel 1, 2-4

E

Error/Event Queue, 3-3
 SCPI Error Codes, 3-4
Examples of Using SCPI Commands, 3-25

F

Features and Functions, 1-1
Front Panel SRQ LED, 2-4

G

Global Channel 0, 2-4

I

IEEE-488.2 and SCPI Conformance
 Information, 3-6
IEEE-488.2 Common Command
 Subsystem, 3-8
 *CLS, 3-8
 *ESE, 3-8
 *ESR?, 3-8
 *IDN?, 3-8
 *OPC, 3-8
 *RST, 3-8
 *SRE, 3-8
 *STB?, 3-9
 *TST?, 3-9
 *WAI, 3-9

L

Local Operation, 2-3

M

Master Unit (R Option only), 2-4
MEASure[n], 3-13
Multiple Source Control with the
 S Option, 2-6
RS-485 Rear Panel RJ-11 Connector
 Pinout, 2-6

-
- O
- Operation Status and Questionable Status Registers, 3-3
 OUTPut[n], 3-14
- P
- Parameter Definitions, 3-6
 0+NR1, 3-6
 0+NRf, 3-6
 boolean, 3-6
 NR1, 3-6
 NRf, 3-6
 string, 3-6
 Power-On Conditions, 2-3
 Default, 2-3
 Protection Event Status Register, 3-3
- Q
- Queries, 3-7
- R
- R Option, 1-1
 Ramping
 Description, 3-19
 Rear Panel Configuration Switch
 Address Selection, 2-4
 Power-On GPIB Service Request (PON SRQ) Selection, 2-4
 Remote/Local Selection, 2-3
 Rear Panel Configuration Switch S1, 2-2
- Remote Operation, 2-3
 Remote Programming via RS-232, 2-5
 RS-232 Rear Panel RJ-11 Connector Pinout, 2-5
- S
- S Option, 1-1
 SCPI Command Operation
 CALibrate[n], 3-10
 MEASure[n], 3-13
 OUTPut[n], 3-14
 Warning, 3-14
 SOURce[n], 3-15
 STATus[n], 3-20
 TRIGgered[n], 3-24
 Serial Poll Operation, 3-6
 Setup Procedure, 2-1
 Slave Unit (S Option only), 2-4
 SOURce[n], 3-15
 Specifications, 1-2
 Standard Event Status Register (ESR), 3-2
 Status Byte, 3-1
 Status Flags Register, 3-19
 STATus[n], 3-20
- T
- TRIGgered[n], 3-24
- U
- Units, 3-7